

Campus Design Guidelines

FACILITIES & CAMPUS SERVICES



WAKE FOREST
UNIVERSITY



Campus Design Guidelines

©2015 Wake Forest University

First edition, published January 15, 2015.

Table of Contents

BY MASTERFORMAT® SECTION

Campus Design Guidelines

Procurement & Contracting Requirements	00
General Requirements	Division 01
Existing Conditions	02
Concrete	03
Masonry	04
Metals	05
Wood, Plastics & Composites	06
Thermal and Moisture Protection	07
Openings	08
Finishes	09
Specialties	10
Equipment	11
Furnishings	12
Special Construction	13
Conveying Equipment	14
Fire Suppression	21
Plumbing	22
Heating, Ventilation & Air Conditioning	23
Integrated Automation	25
Electrical	26
Communications	27
Electronic Safety & Security	28
Exterior Improvements	32
Utilities	33
Transportation	34



General Requirements

DIVISION 01

Campus Design Guidelines

Contents

01-02	Quality Assurance Provision	01-13	Asbestos Surveying, Lead and Abatement	01-01
01-02	General	01-13	Temporary Utilities and Services	
01-03	Adherence to the Campus Master Plan	01-13	Contractor Parking and Construction Traffic	
01-03	WFU Project Development and Design Review	01-14	Demolition and Construction Waste Management	
01-03	Planning and Design	01-16	Construction Signage	
01-03	Construction Delivery	01-16	Ensuring Construction Quality and Design Intent	
01-04	Drawings, Details and Specifications	01-17	Attic Stock Provisions to Be Included In Construction Costs	
01-04	Contracts	01-18	01 7419 – Construction Waste Management	
01-05	Applicable Codes and Regulations	01-19	01 7500 Conservation of Materials and Resources	
01-05	Sustainability at Wake Forest University	01-19	01 8210 – Slabs and Floors on Grade	
01-06	WFU Room Numbering Guidelines	01-20	01 8310 – Structure, Elevated Floors, and Roofs	
01-06	Space Guidelines	01-21	01 8320 – Shell, General	
01-06	Information Technology and Telecommunications	01-22	01 8330 – Exterior Wall Cladding	
01-07	Media Solutions (A/V)			
01-08	Vending and Food Service			
01-09	Mail Services			
01-09	Housekeeping and Janitorial Services			
01-11	Wellness Rooms			
01-11	Laboratory Design			
01-12	Flammables in Buildings			
01-12	Hazardous Materials			

List of Figures

01-17 *fig. 01a: Construction Signage*

Quality Assurance Provision

All work on campus is to be pursued to the highest quality possible within the University's budgetary constraints. It is the intent of the University Administration and its students that all facilities be designed and constructed to last 100 years and beyond. It is unlikely and not preferred that buildings be demolished. Sustainability is a core value at Wake Forest University. By extension, re-using, re-purposing, renovating and remodeling are preferred design approaches to existing structures.

General

These design guidelines are utilized on each University project. Variances from these guidelines shall be submitted to Facilities and Campus Services and, if approved in writing, may be incorporated into the program for a specific project. These guidelines, along with the project program, set the standard of quality for a complete building that is fully functional, operational, and ready for occupancy while allowing the design and construction team a wide degree of latitude in their response to fulfill these requirements. Where these requirements are silent on any material, product, or system that is necessary to construct a building that is fully functional, operational, and ready for occupancy in compliance with these requirements and the project program, the design shall provide such material, product, or system that is of the same quality as the other materials, products, and systems allowed by these requirements.

In general, these design guidelines are written to clarify process, direct designers and contractors to resources maintained by the University that dictate preferences for materials, products, assemblies and respected and endorsed trade or discipline specific standards. These design guidelines do not dictate style, building massing or building typology. with the exception of the University's preferences for certain materials with regard to maintenance and consistency, these guidelines do not address the governance of appearance or campus vocabulary. For aesthetic and contextual fitness of design considerations, the University's current master plan and associated guidelines shall be consulted.

The Code (i.e. the building code and other applicable codes including local, state, and federal regulations) represents the lowest standard that is legally permitted, and in some cases may not represent a long-term, good-value standard of quality for university buildings. All portions of the project shall comply with or exceed the code's minimum requirements. The project is not exempt from City, County, or other regulatory requirements.

The University has developed and maintains forms for internal and external

GENERAL REQUIREMENTS

01-03

use. For additional information regarding University forms and policies, refer to <http://facilities.wfu.edu/working-with-us/forms-and-policies/>.

Adherence to the Campus Master Plan

Wake Forest University abides by the current, adopted Reynolda Campus Master Plan for the development and planning of the campus. In 2007 the University embarked on a planning effort that set out to extend the original vision in the 1950 master plan for another 50 years. All campus development, building demolition, building additions, renovations, road and pathway planning and landscape design is interpreted by Facilities and Campus Services as it relates to the direction set forth in the Master Plan. The master plan may be accessed here: <http://facilities.wfu.edu/build/master-plan/>.

WFU Project Development and Design Review

The University follows the current version of the “Recommended Process and Procedures” for Facilities Planning and Space Management, initially set forth in 2007. This document outlines internal processes for facilities and space planning. The Recommended Process and Procedures covers everything from Space Inventory (existing space) to the Assessment of Project Needs to Project Funding and Prioritization. Included also is the recommended flow for decision making and forms for making space requests and Space Planning Guidelines. The Space Guidelines and Procedures may be accessed from this website: <http://facilities.wfu.edu/build/guidelines/>.

Planning and Design

In general buildings should be detailed and specified to last. 100-year buildings shall be the standard unless otherwise directed by the Facilities and Campus Services group. The design team should take into account ongoing and long-term maintenance, fitment and durability of all materials and assemblies. The design should take into account campus growth and the flexibility and adaptability of a building to be modified to accommodate changing needs over time. In all instances accessibility and universal design principles should guide decision making.

Construction Delivery

Small to medium sized projects are typically Design Bid Build. Larger projects are typically Design/ Construction Manager at Risk.

- ◆ *Design: Typically a RFQ or RFP is issued to select consultants the*

University believes would be well-suited to address the project needs. Responses are reviewed and a shortlist of qualified consultants is developed followed by consultant interviews. The design team is selected and begins work upon notice to proceed by the University.

- ◆ *Construction: 2-3 vendors or contractors are invited to provide quotations which are evaluated for fitness. All other things being equal, the contract is awarded to the lowest quoting vendor or contractor.*

The scope of work will be defined by written documentation and construction contract documents and issued for bid. Generally, the lowest qualified bid is accepted.

For projects the University believes are best suited to a Construction Manager at Risk procurement method, the University will select a CM-R through a competitive, invitation only process, based on the experience, fee, general conditions structure and costs, preferences for contingencies, and the designer's recommendation.

Drawings, Details and Specifications

Project documentation and design team responsibilities are defined by their contract with the University and by the architect's, engineer's and other design consultant's professional standards of practice. The University has developed a Drafting Services Specification List which includes scoping, minimum content, graphic and accuracy standards, and CAD delivery requirements: <http://facilities.wfu.edu/build/guidelines>. This document is meant to supplement the professional codes of conduct for each discipline and the contract between the University and the design team. The contract will supersede in the event of contradictions between the documents.

Contracts

This section includes the following:

- ◆ *services procurement*
- ◆ *contract administration*
- ◆ *vendor and contractor pre-qualification*
- ◆ *construction bidding and forms*

Wake Forest University maintains a guideline for the procurement of vendor and contractor services. This document is entitled "Facilities and Campus

GENERAL REQUIREMENTS

01-05

Services Contract Administration” and may be obtained via written request to the Facilities and Campus Services or WFU Purchasing Department. The procurement process varies depending on the anticipated cost of work or purchase value of service.

Wake Forest University prefers to obtain services from pre-qualified vendors and contractors. Notify the office of Facilities and Campus Services or the University’s Purchasing Department of your interest in bidding on future work at the University and they will provide you with the proper forms and usher you through the process. Information may also be obtained from <http://finance.wfu.edu/suppliers/working-with-wake-forest>.

Work resulting in costs approaching \$80,000 is contracted via a Contractor Services Agreement or CSA. Work exceeding \$80,000 is contracted using an American Institute of Architects or AIA contract as set forth and modified by WFU.

Applicable Codes and Regulations

All new construction, renovations, alterations and improvements on campus shall be in conformance with the current, adopted North Carolina Building Code. The City-County Planning board of Winston-Salem and Forsyth County has adopted Unified Development Ordinances (UDO) that are applicable to development on Wake Forest’s campus. The UDO is the compilation of regulations that affect land use, including Zoning and Environmental Ordinances.

Sustainability at Wake Forest University

Sustainability is a core value at Wake Forest University. The Office of Sustainability at WFU was opened in July 2009. “The Mission of the Office of Sustainability is to encourage and facilitate the collaborative efforts of faculty, students, and staff to generate knowledge, acquire skills, develop values and initiate practices that contribute to a sustainable, high quality of life on campus, in the Triad and across the globe.” More information can be found at <http://sustainability.wfu.edu/>.

In 2012, WFU set strategic goals for increasing sustainability across the campus community. Many of those goals pertain to the physical environment of the campus and building performance. The plan is to meet those goals by 2015. The following are specific goals that are expected to be part of any renovation and new construction efforts at WFU:

- ◆ *Optimize the use of existing space before constructing new buildings.*
- ◆ *Design, build and renovate buildings that are adaptable and*

responsive to occupant behaviors.

- ◆ *Construct and renovate buildings to at least LEED-Silver standards to optimize energy and water performance in all new construction and major renovations.*
- ◆ *Consider opportunities for on-site generation of renewable energy on campus.*
- ◆ *Develop storm water harvesting applications that allow water reuse for non-potable needs and reduce demand on the domestic water supply.*

WFU Room Numbering Guidelines

Wake Forest University adopted Postsecondary Education Facilities Inventory and Classification Manual (FICM) for space standards and facilities organization. As a supplement to the FICM, WFU has developed a Room and Door Numbering Guide that should be applied to all University projects: <http://facilities.wfu.edu/build/guidelines>. If there are existing conditions that do not correspond to the “Guide”, contact the Facilities PM in charge.

Space Guidelines

Wake Forest University follows “Space Planning Guidelines” which were developed as part of the 2007 “Facilities Planning and Space Management: Recommended Process and Procedures”. While each project and University department is unique, WFU seeks to unify development across the campus. The Space Planning Guidelines should be carefully reviewed with the F&CS PM for relevance and application to each project: <http://facilities.wfu.edu/build/guidelines>

The Space Management Office organizes and archives paper plans, cad files, digging permits, digital project files and information on campus site utilities. This office employs in-house utility locators and issues digging permits. Refer also to Division 2 documentation for additional information on digging certificates and site work.

Information Technology and Telecommunications

At Wake Forest University, computing, telecommunications and multimedia services are provided by the Information Systems Department. Design and installation of all information technology infrastructure and equipment at Wake Forest University shall follow BICSI (The Building Industry Consulting Service International, Inc.) guidelines. <https://www.bicsi.org/default.aspx>.

Facilities and Campus Services and the Information Systems Department

GENERAL REQUIREMENTS

01-07

should be consulted early in the project development. WFU will provide additional instruction on the requirements for telecommunications rooms and cabling. Key elements in new construction and renovations programs are:

- ◆ *MDF room – (Main Distribution Frame) is preferably located off a main corridor on the ground or basement level of the building near the telecommunications service entrance. The MDF room shall not be less than 100 square feet and shall be sized to accommodate all equipment necessary for serving the entire building. MDF rooms shall be secured by card access control and shall be dedicated to IT/Telecommunications service. Combined services, such as electrical distribution, storage, mechanical or janitorial, are not acceptable. The MDF shall have a dedicated phone switch shelf. WFU employs both switched and Voice over IP telecommunications.*
- ◆ *IDF room(s) – (Intermediate Distribution Frame) is also preferably located off a main corridor on each floor of the building and shall stack to allow backbone or infrastructure cabling to efficiently route vertically through the building. IDF rooms shall be secured by card access control and shall be dedicated to IT/Telecommunications service. Combined services like electrical distribution, storage, mechanical or janitorial are not acceptable.*

Typically, WFU hires a third party contractor to install and commission cabling and hardware for these systems. Infrastructure, including dedicated telecommunication rooms, cabling pathways, power service, and all required junction boxes, pull boxes and back boxes, will be part of the construction documentation and construction contract. The Information Systems Department will assist in the composition and editing of project specifications. It is the preference of the University that the most advanced and most current cabling at the time of construction is installed in their facilities. This allows for the greatest flexibility and adaptability over time.

Media Solutions (A/V)

At Wake Forest University, multimedia solutions (or audio visual technology) is managed under the Information Systems Department. The Multimedia Department sets the standards for the campus, trains faculty and staff on equipment, maintains cable TV and multimedia systems and researches new methods of implementing technology solutions in the classroom, conference rooms and

wireless system across campus.

Technology for multimedia solutions is constantly evolving, therefore standards are updated frequently. ICIA (InfoComm International Association) and ANSI set industry accepted performance standards and rules of thumb for the information communications industry. The Media Solutions group employs these standards as a starting point and goes further to customize requirements and methods specific to WFU. The Media Solutions group shall be consulted early in the design process, preferably during programming and schematic design, to ensure that the most current technology and thinking specific to Wake Forest University is taken into account. User education on the complexity, use and cost of these systems begins at this point as well. Accurately accounting for A/V cost in the total project budget is key early on, and designers will be expected to facilitate this process.

Vending and Food Service

Vending at food service at Wake Forest University is managed by Dining Services. Vending services are provided through Aramark Refreshment Services, Pepsi and CocaCola. Each academic and residence hall shall be planned to accommodate at least one machine from each vendor for a total of three machines. Every effort should be made in design to locate these on the interior of facilities. Vending machines may be located on the exterior of buildings when renovations of existing buildings do not allow for them to be incorporated within the interior of the building due to existing conditions or when overridden by other building program elements. Depending on the size and design of the facility, multiple vending locations may make sense. The intent is to provide students and faculty with adequate selection and accessibility.

Each machine location is to accommodate at least a 3 foot deep x 4 foot wide machine. Provide Power and data connection for each machine. Some machines will work with wireless devices. Connectivity and distribution should be discussed with Facilities and Campus Service and Dining Services during programming and schematic design. Provide floor protection underneath vending machines when any carpet, wood or resilient floor is used or exists.

The University currently contracts exclusively with Aramark for food service. All new work, renovations and modifications to dining facilities must be in consultation with Aramark and their franchisees (or other current provider) through WFU F&CS. Some franchises have specific design and aesthetic requirements that must be considered in the design of renovated or new facilities. Sustainability and energy efficiency shall be key considerations in the design of

GENERAL REQUIREMENTS

vending and food service projects. Consider the use of no light or low light machines, photosensitive lighting and motion sensing for energy conservation.

01-09

Mail Services

Mail Services at Wake Forest University is located on the First Floor of Poteat Hall. All mail and parcel deliveries at the University go through Mail Services. Mail Services functions as a full service post office, Fedex Drop Off, handles inter-departmental/ inter-campus mail and student P.O. Boxes. Student P.O. Boxes are located in the Benson Center. It is the intent that WFU maintain a central location for student mail rather than a dispersed resident hall centric configuration. Therefore mail boxes and mail services need not be considered in residence hall renovation and new building projects. Similarly, faculty and staff mail is transmitted from or through mail services to each department and is handled independently by department from there. Therefore there are no WFU standards for mail slots. Instead each project in which administrative and office program is part of the scope will be designed per that departments requirements.

Housekeeping and Janitorial Services

Wake Forest University embraces an engineered cleaning protocol in which a standardized process is followed for each building. As such there are minimum requirements for custodial services in WFU facilities. The following are the support spaces for janitorial services that shall be programmed for each new or renovated building:

Check-in Area: Each building shall have a check-in room for Janitorial staff. This room is to be a minimum of 100 square feet with no room dimension less than 7 feet in length. The following requirements are to be discussed with Facilities and Campus Services regarding their applicability in the Check-in area:

- 01.1 Washer/Dryer
- 01.2 Time Clock
- 01.3 Sinks, floor or wall mounted
- 01.4 Chemical Storage
- 01.5 Air Change Rates
- 01.6 Bulk Storage
- 01.7 Card Access
- 01.8 Furniture (Custodial Supervisor Desk)
- 01.9 Information Board
- 01.10 Wall mounted cabinetry and shelving
- 01.11 Floor space for equipment

01.12 Hardware for wall mounting tools

Bulk Storage Room: Each building shall have dedicated space for bulk storage of housekeeping materials. This room may be inside the check-in area and, if so, must be protected by a chain-link fence from floor to ceiling with access control as approved by Facilities and Campus Services. This room shall be located in the building so that it is accessible without having to use stairs or traversing through carpeted spaces. The bulk storage room shall be located near to and on the same floor as the loading or receiving area of the building. In addition, locate the bulk storage room in close proximity to an elevator servicing all floors of the building. Utility services for washers and dryers shall be provided in each bulk storage room. The size of the building will dictate the number of washers and dryers required.

toilet Room Pantry: toilet rooms should be back to back and stacked if at all possible and shall have a 2 foot x 3 foot pantry located in close proximity to the pair of rooms. This pantry shall have a minimum of two shelves that extend the full 3 foot length of the room and are capable of storing a one week supply of toiletry materials. The door shall open out to the corridor and the room need not have a floor drain.

If the Men's and Women's toilet rooms are not paired or are not in close proximity to one another, a pantry as described above shall be provided at each room.

Microfiber mops and cleaning cloths are used for cleaning by housekeeping and janitorial services staff. Designers shall consider the use of these materials when designing and specifying finishes. For example, resinous flooring, which is often used in laboratory, food service, utility, greenhouses, etc., has varying texture possibilities, many of which are not conducive to the cleaning methods employed by the University. Finishes shall be discussed with the housekeeping and janitorial staff as part of the design process. It is expected that this coordination will occur early in the design of a project.

The engineered cleaning process includes the use of large hand carts for the transport of waste and cleaning products. Storage space for these handcarts shall be carefully considered for location and size in the design of a project. Typically each floor will have at least one handcart and depending on the size of the facility, there could be as many as three.

Housekeeping and janitorial services are to be consulted in determining locations of recycling stations. Recycling stations shall be evenly dispersed throughout the facility and shall be located in high traffic areas. There shall be a minimum of two and as many as three per floor.

GENERAL REQUIREMENTS

01-11

Wellness Rooms

The American Institute of Architects has published best practices recommendations for the design of Lactation Rooms. A lactation room should be located in each building in which 50 or more staff or employees work. These rooms are to be located such that they are universally accessible and are in a safe and clean part of the building. The rooms shall be at least 50 square feet with no dimension less than 5 feet to maintain an accessible turning radius. The room shall be lockable with a deadbolt from the inside, shall provide acoustic privacy with walls extending from the floor to structure above and shall have sound dampening materials in the space such as acoustic ceiling tiles and carpeting.

Lactation rooms shall have a task type chair with arm rests and which is adjustable for seat height and back tilt.

A table or counter shall be provided that is at a minimum 20 inches deep and 30 inches wide with a 30 inch wide clear knee space underneath.

Provide an accessible sink in addition to and adjacent to the table or counter with associated task lighting or overhead room lighting with appropriate light levels on the table surface for work.

Provide soap and paper towel dispenser per University standards.

Power receptacles shall be provided at the counter and on at least two walls.

Provide at least two coat hooks on the back of the door serving the room.

A small refrigerator is recommended, but not required.

Laboratory Design

Wake Forest University requires the development of a Chemical Hygiene Plan and Safety Manual for each laboratory on campus. This plan shall be developed by the University in conjunction with the design/renovation of laboratory spaces. Careful coordination between the design team, the Users and the EH&S department is required to ensure the document is supported by the space and vice versa. The University has adopted and follows the National Research Council's Prudent Practices in the Laboratory as a guide for laboratory use and safety. This document may be found here: http://www.nap.edu/catalog.php?record_id=12654. Coupled with this document is the Chemical Hygiene and Safety Plan, which may be viewed here: <http://www.wfu.edu/physics/doc/DocsPolicies.html>, and a Lab Safety Compliance Kit. The Lab Safety Compliance Kit is to be conspicuously mounted at the entrance to the laboratory.

Flammables in Buildings

Buildings in which chemicals, particularly flammables are used and stored, must be carefully considered for chemical control areas. A chemical inventory, which is analyzed based on the requirements and limitations relative to chemical concentrations and quantities per NFPA and the North Carolina Building Code must be submitted to the department of EH&S along with the building or renovation design documentation.

Hazardous Materials

Wake Forest University is committed to providing a healthy and safe campus. It is WFU policy to comply with all applicable laws, regulations and requirements. Hazardous materials identification and handling is done in consultation with the Office of Environmental Health and Safety at Wake Forest University. WFU has developed a “Space Hazard Assessment” where existing facilities have been analyzed and their hazards or potential hazards documented. Typical spaces that have undergone this analysis include science laboratories, facilities shops, art studios, athletics and other mixed-use spaces. EH&S shall be contacted before disturbing existing materials in any facilities on campus or facilities otherwise owned or operated by WFU.

- ◆ *Lead: It is to be assumed that lead is present in paint in all WFU facilities built prior to 1980. WFU’s Lead Program establishes the minimum requirements for the identification and handling of lead. EHS will advise project planners and managers concerning the lead hazards which affect their project, will perform or commission surveys to assess the presence and scope of lead-containing materials, and will serve as the liaison between WFU and regulating authorities.*
- ◆ *Mold: Wake Forest University and the Office of Environmental Health and Safety operate under the current version of the “Mold Management Plan Operations and Maintenance” document. The Mold Management Plan can be found here <http://facilities.wfu.edu/working-with-us/forms-and-policies/>. This document was developed by EH&S to inform the recognition, prevention, remediation and documentation of mold and moisture incidents in WFU facilities. The procedures and authority of this document extends to new building projects and renovation building projects on campus. The Office of Environmental Health*

GENERAL REQUIREMENTS

and Safety is to be consulted in regards to any mold or moisture incidents. As of this revision of the Design Guidelines, the current version was revised in October 2010.

01-13

Asbestos Surveying, Lead and Abatement

Wake Forest University and the Office of Environmental Health and Safety has developed an Asbestos Management Program to ensure protection measures are in place and responsibilities of all personnel involved with the abatement and handling of asbestos or asbestos containing materials are clearly defined. The program is described in the current version of the Asbestos Management document which is developed by EH&S. WFU has an appointed Asbestos Coordinator who is responsible for overseeing all asbestos surveys and abatement activities and to maintain surveys and records. As of this revision of the Design Guidelines, the current version was revised in September 2009.

All renovation projects should consider whether or not lead may be present. The University should be consulted for existing hazardous materials surveys and reports. In the absence of reports testing existing painted surfaces should be considered.

Temporary Utilities and Services

Unless otherwise stated in the contract, it will be the contractor's responsibility to provide temporary services for all toilet facilities, light and power, water, telephone, contractor's offices and storage sheds, site fencing, on site office for Owner/Architect use, heat and protection of existing facilities or work in place. Designers are to consult with the Facilities and Campus Services office on specific temporary service requirements. These shall be noted in the project manual as required for each specific project. Contractors are to coordinate use of and connection to all existing WFU services with the Facilities and Campus Services. Unless otherwise noted or discussed, Wake Forest University will pay for the costs of all utilities and services required during construction with the exception of fuel for generators.

University access to existing

Contractor Parking and Construction Traffic

Construction parking for project on the Reynolds campus will be limited and will be defined by the contract documents or by the Facilities and Campus Services office in pre-construction meetings. Typically, a dedicated construction parking area, either on or off-campus is designated by WFU and shuttling back

and forth at the contractor's expense is required. Construction staging plans should be included in the design development and construction document submittals.

Existing traffic patterns and use of vehicular and pedestrian roads or paths are not to be impacted by construction activities without written authorization by Facilities and Campus Services. Clean and safe conditions shall be maintained on and around construction sites. The facilities project manager is to be notified at least one week in advance of any need for shutting down existing circulation on campus for any reason.

Demolition and Construction Waste Management

Limiting landfilled materials from demolition and construction activities is key to the sustainability efforts at Wake Forest University. The Facilities and Campus Services department has instituted a C&D Waste Management Process that includes a management plan, requirements for waste management coordination and meetings and implementation strategies.

The contractor is required to submit their C&D Waste Management Plan concurrent with the submission of the initial schedule of values or before the start of demolition, whichever comes first, to the Owner and the Architect for approval. This plan must be coordinated with the demolition and renovation/construction critical path schedule and must at a minimum include the following:

Indicate how the contractor proposes to recover at least 75% of the C&D waste for reuse and recycling.

Include a list of reuse facilities, recycling facilities and processing facilities that will be receiving the recovered materials. Please include any items slated for turning over to the Owner or that the Owner plans to remove prior to completion of demolition or on-site auctions.

If some of the materials will be donated or sold on-site, describe the process and identify the organization that may receive the materials.

Indicate instances or situations where compliance with the requirements of this specification do not apply or do not appear to be possible.

Identify each type of waste material to be reused or recycled and estimate the amount, by weight.

Provide estimate of time requirements for demolition and for the removal of valuable, reusable items and materials.

Provide a C&D site management and site use plan.

Provide final accounting of disposition of recovered materials upon com-

GENERAL REQUIREMENTS

pletion of project for final payments.

The Contractor shall schedule and organize a Pre-C&D Waste Management meeting.

Prior to beginning work at the site, schedule and conduct a meeting to review the C&D Waste Management Plan and discuss procedures, schedules, coordination and specific requirements for waste materials recycling and disposal. Discuss coordination and interface between Contractor, sub-contractors, architect, engineers, project manager, Owner and other C&D activities. Identify and resolve problems of compliance with requirements, record meeting minutes, identify conclusions reached during the meeting and matters requiring further discussion or research to determine resolution. Maintain waste management as an agenda item at future construction meetings.

Attendees for meeting: Contractor and related contractor personnel associated with work of this section, including personnel in charge of the waste management program; architect; engineers; material and equipment suppliers where appropriate; and such additional Owner personnel as Owner deems appropriate.

Plan Revisions: Make revisions to C&D Waste Management Plan agreed upon during the meeting and incorporate resolutions agreed to be made subsequent to the meeting. Submit revised plan to architect or the Owner personnel as Owner deems appropriate for approval.

Implementation:

- ◆ *Designate an on-site party responsible for instructing workers and implementing the C&D Waste Management Plan.*
- ◆ *Distribute copies of the C&D Waste Management Plan to job site foremen and each subcontractor.*
- ◆ *Include waste management and recycling in worker orientation.*
- ◆ *Provide on-site instruction on appropriate separation, handling, recycling and recovery methods to be used by all parties at the appropriate stages of the work at the site.*
- ◆ *Include discussion of waste management and recycling in regular job meeting and job safety meetings conducted during the course of work at the site.*
- ◆ *Conduct construction and demolition in such a manner to minimize damage to trees, plants and natural landscape environment.*
- ◆ *Arrange for adequate collection, and transportation to deliver the recovered materials to the approved recycling center or processing facility.*

- ◆ *Maintain records accessible to the Owner's representative for verification of diversion of recovered waste materials.*

This list of materials is not all inclusive and it should be edited for each specific project. At a minimum the following materials are to be diverted from landfills:

- 01.13 Asphalt
- 01.14 Concrete and concrete masonry units
- 01.15 Porcelain, terracotta and clay based masonry materials
- 01.16 Ferrous metals
- 01.17 Non-ferrous metals
- 01.18 Untreated lumber
- 01.19 Plywood, OSB, particle board
- 01.20 Gypsum wallboard and drywall scrap
- 01.21 Paper and cardboard
- 01.22 Beverage containers
- 01.23 Insulation
- 01.24 Rigid foam
- 01.25 Glass
- 01.26 Carpet and pad
- 01.27 Trees and shrubs
- 01.28 Soil

Construction Signage

Construction signage is to be 4 feet x 8 feet and either approved by or designed by the WFU University Architect. The University Architect may provide a template to the design team for use in the contract documents. The Contractor is always responsible for providing and maintaining construction site signage. The contract documents shall be clear about this responsibility. ***The figure on the opposite page contains two examples developed from the WFU template for construction signage.***

Ensuring Construction Quality and Design Intent

Mock-Ups shall be considered for exterior walls systems, Student rooms (including furniture layouts), Interior signage, fascia, roofing, windows and other repetitive and either highly visible or key to building maintenance and operations. Use of Color – refer to <http://identitystandards.wfu.edu/>

GENERAL REQUIREMENTS

WAKE FOREST UNIVERSITY
Facilities and Campus Services

New Welcome Center
Opening Fall 2010

Owner:
Wake Forest University
Keith Coulston, Assoc. Dir. for Project Management - 336.758.4074

Construction Manager:
Landmark Builders

Architects:
Lambert Architects + Interiors

Civil, Structural & Landscape:
Stewart Engineering

Mechanical, Electrical & Plumbing:
Stanford White Inc.

Under Construction
Oct 2009 - Oct 2010

Design
Neo-Georgian Style
20,000 square feet
LEED Silver Goal

Key Elements
Welcome & Reception
Auditorium Seating
Student Interview Rooms
Admissions Staff Office & Work Space

Opening Fall 2010

WAKE FOREST UNIVERSITY
Facilities and Campus Services

NEW Suite Style Residence Halls
Opening August 2013

Owner:
Wake Forest University
Campus Contact: Paul M. Bonick, AIA, LEED AP
Sr. Project Manager - 336.758.4899

Construction Manager:
Frank L. Blum Construction

Architects:
Hanbury Evans Wright Vlattas + Company

Civil & Landscape:
Stimmel Associates, PA

Structural:
Sutton-Kennerly & Assoc.

HVAC, Electrical, Plumbing, Fire Protection:
Newcomb & Boyd

Design
2 New Buildings
480+ Total Beds
80,000 sf / Building
Georgian Architecture
LEED Silver Goal

Under Construction
March 2012 - August 2013

Suite Style Hall
4, 6 & 8 Bed Units
Lounge/Kitchen each floor
Study Room each floor
Media/Game Rooms
Laundry in each building
Lounge/Commons

Community
4 Total New Student Organization Spaces

Opening August 2013

fig. 01a: CONSTRUCTION SIGNAGE

Construction signage is to be 4 feet x 8 feet and either approved by or designed by the WFU University Architect. The University Architect may provide a template to the design team for use in the contract documents.

Attic Stock Provisions to Be Included In Construction Costs

For ongoing operations and maintenance paint, roofing, flooring, ceiling tiles, wall base, lamps and belts shall at a minimum be included.

01 7419 – Construction Waste Management

During Construction:

- ◆ *Require the contractor to submit a plan to minimize construction waste and landfill and to optimize reuse, repurposing, and recycling of construction materials, both existing (if any) and new. Plan to be submitted to Megan Anderson at andersmm@wfu.edu. Evaluate potential existing and new construction products and waste, and specify appropriate requirements for each, such as:*

- 01.29 cardboard
- 01.30 wood pallets
- 01.31 dimensional wood
- 01.32 land clearing debris
- 01.33 concrete
- 01.34 clay masonry
- 01.35 concrete masonry
- 01.36 asphalt paving
- 01.37 concrete paving
- 01.38 metals, segregated as to material
- 01.39 glass
- 01.40 gypsum products
- 01.41 plastic buckets
- 01.42 carpet and carpet cushion
- 01.43 shingles
- 01.44 paint waste
- 01.45 foam insulation
- 01.46 plumbing fixtures
- 01.47 mechanical equipment
- 01.48 electrical equipment
- 01.49 wiring
- 01.50 ceiling tile and panels

- ◆ *Provide a central location for collection and sustainable disposal (reuse, repurposing, recycling) of construction waste, sorted and categorized as to type (material) and final destination.*
- ◆ *Require the contractor to report on plan implementation.*

GENERAL REQUIREMENTS

01 7500 Conservation of Materials and Resources

During Occupancy: The Program for the building shall include a central location for collection, compaction, and storage of recyclables such as:

- ◆ *Paper*
- ◆ *Aluminum*
- ◆ *Plastic*
- ◆ *Cardboard*

01-19

01 8210 – Slabs and Floors on Grade

Floor flatness: Not more than 1/4" over a 10 foot straight-edge (measured at the interior for concave surface and at the ends for convex surface).

Floor Classifications:

- ◆ *ACI 302.1R-2004 Class 4: Minimum 28-day compressive strength of 4000 psi; maximum slump of 5 in; normal steel-troweled finish.*

Exterior Slabs, Walks, and Pavements:

- ◆ *Water-Cement Ratio: For concrete slabs on grade that are partly or completely exposed to freezing conditions, durability requirements typically trump strength requirements. Specify concrete mix design by water-cement ratio or cement content or both rather than compressive strength alone. (Compressive strength tests can be useful during construction to verify that batching, mixing, and curing were adequate as evidenced by strength meeting and expected level typical of that water-cement ratio and cement content.)*
- ◆ *Air Content: For concrete slabs on grade that are partly or completely exposed to freezing conditions, provide air content in accordance with recommendations of ACI 201.2R-2001. This guideline will limit the minimum compressive strength for exterior slabs to 4,000 psi concrete.*

For vapor control of slabs on grade, see Section 07 2614 – Above-Slab Vapor Retarders and Section 07 2617 – Under-Slab Vapor Retarders.

01 8310 – Structure, Elevated Floors, and Roofs

Floor Flatness: Variation not more than 1/4" over a 10 foot straight-edge (measured at the interior of the straightedge for concave surface and at the ends for convex surface). Refer to the ACI Manual for more guidance regarding floors in more critical occupancies.

Structure Supporting Floors and Roofs – Use one or more of the following:

- ◆ *Structural steel beams, columns, girders, joists, and wind-bracing.*
- ◆ *Cast-in-place reinforced concrete beams, columns, walls, girders, and joists.*
- ◆ *When approved by the Facilities and Campus Services: Shop-fabricated panel system comprising load-bearing light-gage steel framed panels.*
- ◆ *Freshman Residence Halls: Load-bearing masonry walls.*
- ◆ *Light frame wood: not permitted.*

Elevated Floors and Roofs – Use one or more of the following:

- ◆ *with steel frame: Concrete-filled composite steel deck.*
- ◆ *with cast-in-place frame: Cast-in-place reinforced concrete slabs, minimum 4 inches thick.*
- ◆ *Freshman residence halls: Precast concrete slabs covered with minimum 1-1/2 inches concrete.*
- ◆ *Light frame wood: Not permitted.*

Roof Decks sloped not less than 1/4 inch per foot up to 3 inches per foot – Use one or more of the following:

- ◆ *with steel frame: Concrete-filled composite steel deck.*
- ◆ *with cast-in-place frame: Cast-in-place reinforced concrete slabs.*
- ◆ *Freshman residence halls: Precast concrete slabs covered with concrete topping at least 1-1/2 inches thick.*
- ◆ *Metal roof deck: not permitted.*
- ◆ *Metal form deck with lightweight insulating concrete topping: not permitted.*
- ◆ *Light frame wood: Not permitted.*

GENERAL REQUIREMENTS

01-21

Roof Decks sloped 3 inches per foot and higher – Use one or more of the following:

- ◆ *Metal roof deck.*
- ◆ *Light frame wood: Not permitted.*

Roof Access: Provide doors, access panels, roof hatches, permanent access ladders, stairs, etc., that allow access to each roof area and level. During programming and design, obtain the owner's requirements for frequency and type of inspection and maintenance activities that will be performed on the roof. Where appropriate, include requirements for temporary or permanent tie-offs, guards, etc., in the construction documents.

01 8320 – Shell, General

THERMAL DESIGN CRITERIA:

Comply with ASHRAE 90.1 and additional requirements specified herein (including walls, windows, roofing, etc.).

Water Penetration:

- ◆ *Design and select materials to prevent water penetration into the interior of shell assemblies, under conditions of rain driven by 50 mph wind.*
- ◆ *Exception: Controlled water penetration is allowed if 1) materials will not be damaged by presence of water (including freezing and thawing or other deterioration) and 2) continuous drainage paths to the exterior are provided and 3) water passage to the building interior is prevented.*
- ◆ *The code requirement for design for components and cladding for Wake Forest University's location, with regard to structural performance and life safety, is 90 miles per hour. Most buildings will experience some water infiltration in a 90 mph rainstorm.*
- ◆ *Provide canopies, sheltered recess into the façade, or an equivalent form of rain and weather protection at all exterior doors; construct using permanent materials – not fabric. Protection shall be in keeping with the style and proportion of existing campus exemplars.*

Provide vestibule at main entrances.

Thermal Envelope:

- ◆ *Design attic spaces and plenum spaces in roof-ceilings, if present in the project, as interior conditioned or semi-conditioned space. Locate the thermal/moisture/air/vapor envelope on the exterior side of the roof deck and employ rigid continuous insulation, uninterrupted by framing members. Batt-type and blown-type fibrous insulation not permitted.*
- ◆ *Design basements and crawl spaces, if present in the project, as interior conditioned or semi-conditioned space. Locate the thermal/moisture/air/vapor envelope on the perimeter of such spaces and employ rigid continuous insulation.*
- ◆ *As an alternative to rigid continuous insulation, spray-applied foam insulation (continuous) may be employed as appropriate to project conditions and subject to compliance with code evaluation reports.*

Steel shapes:

- ◆ *Enclosed in a permanently dry environment: Shop primed.*
- ◆ *Enclosed in masonry cavities or similar locations subject to damp conditions: Waterproof modified asphalt coating, 40 mils nominal thickness.*
- ◆ *Embedded in masonry: Type 304 stainless steel. Hot-dip galvanized and plain steel not permitted.*
- ◆ *Exposed to view or to weather: SSPC SP-6 preparation with zinc-rich primer, epoxy intermediate coat, urethane top coat.*

Coated Finish on Steel:

- ◆ *Zinc-rich primer: Inorganic or organic.*
- ◆ *Epoxy intermediate: 2-part catalyzed polyamine epoxy.*
- ◆ *Urethane: 2-part aliphatic acrylic urethane.*
- ◆ *Fluorourethane: top coat for exposed steel that cannot be readily repainted.*
- ◆ *Acceptable manufacturers: Themec, Carboline, PPG.*
- ◆ *Do not use: Baked enamel; single component paint.*

01 8330 – Exterior Wall Cladding

Supporting Structure (back-up) of Walls – Use one or more of the following:

- ◆ *Concrete masonry unit back-up.*

GENERAL REQUIREMENTS

01-23

- ◆ *Steel studs and sheathing.*
- ◆ *Shop fabricated panel structure utilizing cold formed metal framing – when approved by the Facilities and Campus Services.*
- ◆ *Freshman Residence Halls: Load-bearing concrete masonry unit walls.*
- ◆ *Light wood framing not permitted.*

Exterior Skin of Exterior Walls – Use one or more of the following:

- ◆ *Face brick.*
- ◆ *Indiana limestone accents.*

Do not use the following materials for exterior cladding or portions of cladding:

- ◆ *Wood.*
- ◆ *Cast stone.*
- ◆ *Architectural precast concrete.*
- ◆ *Split face, ground face, or other concrete block.*
- ◆ *Glazed structural clay tile.*
- ◆ *Aluminum-zinc alloy-coated steel panels, factory-applied fluoropolymer coating.*
- ◆ *Aluminum panels, factory-applied fluoropolymer coating.*
- ◆ *Mineral fiber cement siding (panel or board).*
- ◆ *Portland cement plaster or stucco.*
- ◆ *Glazed or unglazed ceramic tile or porcelain tile over stucco or masonry.*
- ◆ *Expanses of glass or glazing not in accordance with University Design Guidelines.*
- ◆ *Different metals subject to galvanic action in direct contact with each other.*
- ◆ *Aluminum in direct contact with concrete or cementitious materials.*
- ◆ *Other materials not approved by the Facilities and Campus Services.*

Columns and Trim:

- ◆ *Wood columns and trim are traditional components of exterior campus façades. These traditional materials require repeated and costly repainting as well as periodic maintenance, repair, or eventual replacement that is likewise costly over the long term. In lieu*

01-24

of wood for these elements, evaluate, select, and design alternative materials. Selection criteria should target material durability (as compared to clay brick veneer or limestone), known track record of the alternative material, low-maintenance cost and frequency, and best life-cycle cost (initial and on-going costs expressed as net present value or other single neutral value).

Existing Conditions

DIVISION 02

Campus Design Guidelines

Contents

- 02-02 02 2600 Hazardous Materials
- 02-03 Perimeter Security
- 02-03 Site Surveying
- 02-03 Utility Locating
- 02-03 Geotechnical Surveying
- 02-04 Dig Permits
- 02-04 Campus Tree Care Plan
- 02-05 Storm Water Management
- 02-05 Erosion And Sediment Control
- 02-05 Parking Endowment And Calculations
- 02-06 Exterior Accessiblity
- 02-06 Site Elements
- 02-07 Landscape
- 02-11 Site Lighting

02-01

List of Figures

- 02-06 *fig. 02a: Walkway Materials*
- 02-07 *fig. 02b: Site Walls*
- 02-08 *fig. 02c: Typical Site Furnishings*
- 02-09 *fig. 02d: Typical Bollard & Receiver*
- 02-10 *fig. 02e: Campus Signage Examples*
- 02-11 *fig. 02f: Site Lighting - Acorn Pedestrian Pole*

DIVISION 2

Division 2 bridges multiple disciplines combining into one division existing building conditions, hazardous materials, building demolition, site work, site circulation and landscaping.

02 2600 Hazardous Materials***Refer also to general requirements***

Existing Construction:

- ◆ *Prior to construction, obtain from the University a survey and report by an independent testing laboratory of existing hazardous materials such as asbestos-containing materials, lead-based paint, and PCB-containing equipment or materials. Verify that roofing and waterproofing materials are included in the survey. Verify that the report contains a quantity survey that lists an estimated quantity (each, linear foot, square foot) associated with each material, classified in a form that is useful to tradesmen, estimators, and bidders.*
- ◆ *Require the removal of existing hazardous materials in their entirety using procedures complying with federal, state, and local regulations. Materials will be allowed to remain (encapsulated) in place only when approved in writing by the Office of the University Architect.*
- ◆ *Include in the bidding documents the estimated quantity of each ACM and require bidders to furnish unit prices.*
- ◆ *Where appropriate to the nature of abatement activities, arrange with the University for the services of an independent testing laboratory for air quality monitoring and other QA activities.*
- ◆ *During construction phase, require field reports of abatement compliance.*

Hazardous Construction Materials, New Construction: Asbestos-containing materials, lead-based paint, and PCB-containing equipment and materials are not permitted.

EXISTING CONDITIONS

Perimeter Security

The following goals or guidelines apply to all projects that touch the edges of campus.

- ◆ *The University prefers to establish a consistent fencing system around the entire campus perimeter.*
- ◆ *From a safety standpoint, it is desirable to funnel pedestrian circulation from outside of campus to key control points in the campus perimeter.*

02-03

Site Surveying

Site surveys are conducted for each project. Target areas are identified and requests for surveys are directly routed through the Project Manager in the Facilities and Campus Services (F&CS) Space Management office. Services are contracted out to local surveying companies by the F&CS Space Management office.

Items to be included on the survey can be found in the WFU Topographic Survey Info Sheet. Contact F&CS.

Designers should request a copy of the survey for the project they are working through the Prime Consultant. Upon receipt, the designer should review the document for completeness so if supplemental information is needed it can be prepared to coincide with the project schedule.

Utility Locating

Utilities for the Reynolda Campus properties are located by WFU F&CS in-house locating services. Requests for utility location along public roadways are additional and run through the N.C. One Call Network & Winston-Salem Utilities Division. <http://facilities.wfu.edu/build/space>

The Utility locating service is intended to be done in conjunction with the site surveying phase.

This is required prior to any land disturbing activities.

Geotechnical Surveying

Geotechnical reports are required for each project. These surveys are ordered by the University and are directly routed through the Project Manager. The Designer's responsibility includes identifying target locations and to giving scope recommendations. Any boring, digging or physical ground penetrations must be conducted through the WFU Digging Certificate process.

<http://facilities.wfu.edu/build/space>

Dig Permits

All activities which require digging on any properties owned and maintained by Wake Forest University requires the issuance of a WFU Digging Certificate. This Certificate is issued to a WFU Employee. Allow 2 weeks from the date of request for processing, signatures for approval.

<http://facilities.wfu.edu/build/space>

Information needed for the Dig Certificate:

- 02.1 Work order number
- 02.2 Estimated start date
- 02.3 Project parameters
- 02.4 Project location
- 02.5 Department/Division
- 02.6 Contractor/Vendor/Excavating Crew

Campus Tree Care Plan

The overall goal of the Campus Tree Care Plan is to insure a safe, attractive, healthy and sustainable campus forest. All persons working on Wake Forest Properties are required to have knowledge of these guidelines <http://facilities.wfu.edu/build/space> before design work begins. In the early stages of design the Landscape Department. is required to be notified in order to assess the existing trees and other green spaces within the project limits.

A key element in the initial design phase is analyzing existing trees, especially Heritage and Memorial Trees, within the project. The Campus master plan must be followed, however, great care must be taken to protect existing campus trees. A minimum ratio of 1 foot for every 1 inch in tree caliper shall be applied to existing trees to remain. No disturbance, trenching or improvements are allowed within this zone. Conflicts between the master plan layout and the existing trees must be brought to the attention of the WFU Project Manager.

A tree protection plan is required to be prepared by the designer and approved by the Landscape Service Department of the Facilities and Campus services prior to any construction activities. A proper tree protection area features a chain link fence and clearly labeled tree protection signage. The University's Tree Care Plan can be obtained on this link: <http://sustainability.wfu.edu/resources>

The University has established a Tree Endowment Fund. Projects must replace trees, approved to be removed, with a one-to-one ratio of tree basal circumference as outlined in the campus tree care plan. When a construction project cannot replace all trees on-site, the equivalent value of the trees will be charged to the project.

EXISTING CONDITIONS

Storm Water Management

The purpose of storm water management is to protect, maintain, and enhance the public health, safety, environment and general welfare by establishing minimum requirements and procedures to control the adverse effects on increased post construction storm water runoff, nonpoint and point source pollution associated with development and redevelopment of properties.

The City of Winston-Salem's storm water ordinance must be followed for all construction projects on campus. These regulations must be identified early on in the design process. If the project is deemed not exempt by the City SWM Engineer, the civil consultant must prepare and coordinate the storm water management submittals, as required, to insure the permitting follows the design and construction schedule.

In addition to the code aspect of storm water management the University's liability and effect on adjacent properties should be factored into the early design phase.

LEED sections SSc6.1 SW Design Quantity and SSc6.2 SW Design Quality must be reviewed in the early stages of the design process for possible inclusion into the project. The use of cisterns for collection and storage of non-potable water use must also be considered.

Storm water management strategies shall be coordinated and applied in a comprehensive manner throughout project development.

Storm water detention and retention devices shall be integrated into the site, building and landscape design and shall be aesthetically pleasing.

Low impact design techniques for storm water management are strongly encouraged.

Erosion And Sediment Control

WFU project must comply with the NC Sedimentation Pollution Control Act and the Winston-Salem Sedimentation Pollution Control Ordinance.

http://www.ncga.state.nc.us/enactedlegislation/statutes/html/byarticle/chapter_113a/article_4.html

Parking Endowment And Calculations

Campus parking is regulated by both WFU and the City of Winston-Salem. WFU has a master parking assessment plan that is updated per project by the F&CS Space Management office. The City of Winston-Salem requires WFU to submit an updated plan with each building permit submittal. Currently the WFU F&CS in-house technician updates the electronic Parking Master Plan. Designer

EXISTING CONDITIONS

02-06



fig. 02a: WALKWAY MATERIALS
The location of walkway materials will be dictated based upon the type of project, maintainability, and budget.

must provide the WFU Project Manager with a CAD plan of the project for inclusion into the Parking Master Plan.

Parking, both existing parking spaces and new parking spaces, must be considered in the early stages of the design process. The Designer must understand the program needs of the project, the context of disturbing existing parking spaces and the effect on the Master Plan. Conflicts must be brought to the attention of the WFU Project Manager immediately so proper conflict management and decisions can be made.

The removal of parking spaces within a project boundary must be approved by the Parking Committee.

The University has established a Parking Endowment Fund. If parking is removed from a project boundary, the project must bear the cost of removing the parking and providing additional spaces elsewhere.

Parking requirements by the City are based upon 3 principle uses. Projects that expand classroom space, administration and office space and dormitory bedrooms will require parking. All other uses are considered accessory uses to the main Campus and do not currently have City requirements. The current minimum requirements require the following ratios;

Provide 1 space per 575 SF of classroom space

Provide 1 space per 350 SF of gross floor area of administrative and office space.

Provide 1 space per dormitory bedroom.

The parking ratios above are the City's parking requirements and must be verified by the Designer for possible ordinance changes. Also the Designer must verify the projects parking needs that may be above a code minimum requirement. Designer should consult the City of Winston-Salem's Unified Development Ordinance.

<http://www.cityofws.org/departments/planning/zoning-and-subdivision>

Exterior Accessibility

Accessible routes for disabled persons must conform to the details and guidelines in the Americans with Disabilities Act and applicable State/Local codes. These accessible routes must be considered early in the design phase.

An accessible route must always be provided to the accessible entrance.

Site Elements

Walkways will incorporate brushed concrete, Deacon Blend brick pavers by Pine Hall Brick, permeable Deacon Blend Storm Paver brick or blue stone slate.

EXISTING CONDITIONS

The location of these materials will be dictated based upon the type of project, maintainability, and budget. *Refer to figure 02a.*

Seating walls and highly visible retaining walls shall consist of brick facing with a granite, limestone or precast caps. Old Virginia brick veneer is to be used for all site walls similar to exterior walls of adjacent campus buildings. Other wall types can be considered for retaining wall that will not be view by the public. *Refer to figure 02b.*

Site furnishings shall be selected on a project by project basis. The Campus standard for benches, chairs, tables and swings will be specified from Wabash Valley painted or powder coated black or Kingsley-Bates teak. Bike racks are Heavy Duty Challengers by Madrax Trilary, Inc. Outdoor grills from R. J. Thomas Mfg. Furnishings. Bike racks grills and similar appurtenances are to be surface mount bolted, not embedded. *Refer to figure 02c for a summary of manufacturer and model numbers.*

Security barriers and removable bollards to be cast aluminum painted or powder coated black by Visco. *Refer to figure 02d.*

Campus signage is broken down into the following categories; Exterior signs, Building Identification Signs, Pedestrian Orientation Signs, Message Kiosk, Parking Identification Signs and Vehicular Directive Signs. *Refer to figure 02e.*

Landscape

Plant material should be selected to provide a valuable landscape amenity that is both attractive and meets the sustainability goals of the master plan. Plants should be chosen for their relative visual merits and their ability to thrive in the intended locations. Plants should be native and selected for reduced demand for water, fertilizers, pesticides and maintenance.

Turfs and grass shall only be premium turf type fescues with 5% maximum bluegrass. Contractor's blends, rye grass, Kentucky 31 types grasses are not acceptable. Plant bed mulch shall consist of double shredded hardwood. River stone mulch with a Curlex Excelsior geotextile underlayment shall be placed around yard drainage inlets. Specifications shall be incorporated into the landscape bid set to require the Contractor not to bury the construction debris, rocks and gravel.

The decision to use site irrigation is based upon a project by project basis. The Designer must verify the use with the WFU Project Manager. The University is applying sustainable principles throughout the campus and the Designer must ask the WFU Project Manager if the use of rainwater reuse systems are within the construction budget. If site irrigation is part of a project Toro brand systems

02-07

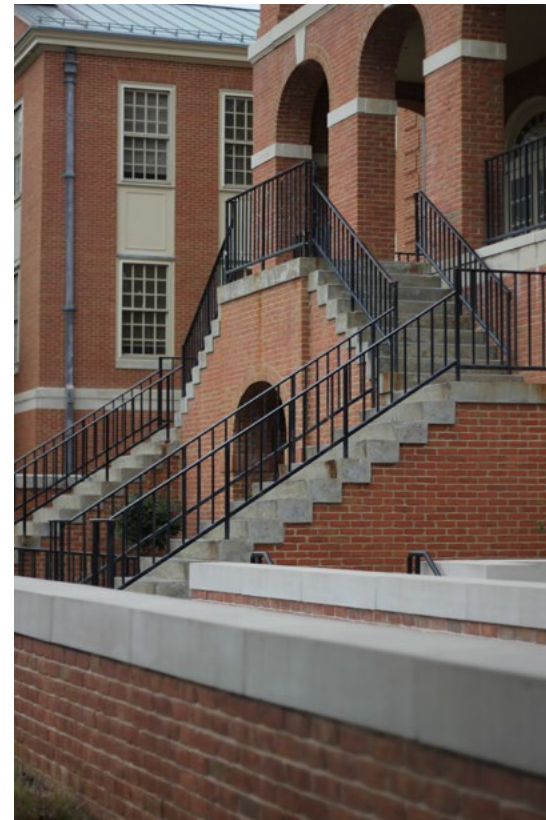

fig. 02b: SITE WALLS
Seating walls and highly visible retaining walls shall consist of brick facing with a granite, limestone or precast caps.

02-08

Wabash Valley		
Vendor SKU	Description	Style
D-PP203-Black-Black	46" Octagon Table w/ 4 seats	Surface Mount
D-PP208-Black-Black	46" ADA-Octagon Table w/ 3 seats	Surface Mount
D-PP100-Black-Black	46" Octagon Table w/ 4 seats	Portable
D-PP105-Black-Black	46" ADA Square Table w/ 3 seats	Portable
D-SG201-Black-Black	6' Single Pedestal Picnic Table	In-ground
UM110	9' Fiber-Built Market Umbrella, Crank Lift	Portable
LR300D	32 Gallon Receptacle, Diamond, Black	Portable
LR310N	32 Gallon Rigid Plastic Receptacle Liner	
DT101N	Recycling Dome Top Lid, Black	
DT100	Black Dome Top Lid	
Kingsley-Bates "ALL Teak"		
TR30	Essex 30" Bistro Table	
TR36	36" Round Table	
TR37	Essex 36" Round Bar Table	
TR42	Essex 42" Round Dining Table	
TR50	Essex 50" Round Dining Table	
AK25	Adirondack Chair	
AK05	Adirondack Ottom	
CL18	Classic Arm Chair	
CL18A	Armchair	
NT18	Nantucket Bar Chair	
HP40	4' Hyde Park Bench	
HP50	5' Hyde Park Bench	
HP60	6' Hyde Park Bench	
MD70	Chaise Louinge Chair	
MD44	Coffee Table 24"x45"x15.5"	
MD98	Dining Table	
NT20	Nantucket End Table	
CD25	Rocking Chair	
MD14	Side Chair	
CT55	Chat Table	
CO30	Chelsea DS Lounge Chair	
CR25	Charleston Rocker	
MU02	10' Market Umbrella 2" Pole	
MU02 Canopy	CVR02-6446 Forest Green	
MB02	50lb. Umbrella Base, 2" Pole	
CO45	Chelsea 4.5' Bench	
Madrax Trilary, Inc		
H36 Series	Heavy Duty Challenger	Surface Mount
R.J. Thomas Mfg.		
EC-40/S B2	Outdoor Covered Grill	In-ground
EC-40/S B3	Outdoor Covered Grill	Surface Mount

fig. 02c: TYPICAL SITE FURNISHINGS

EXISTING CONDITIONS

02-09

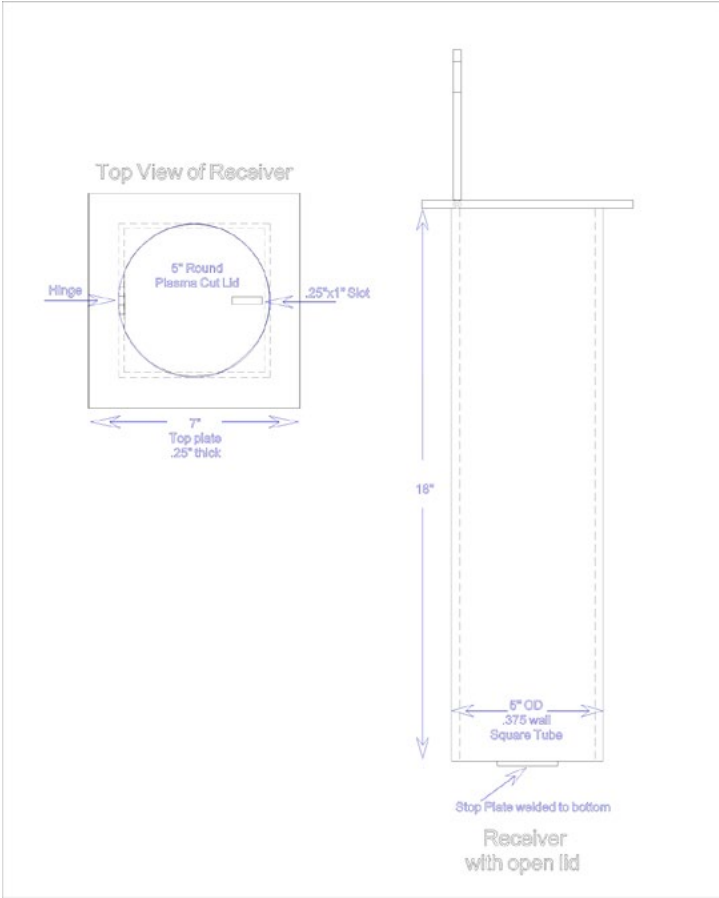
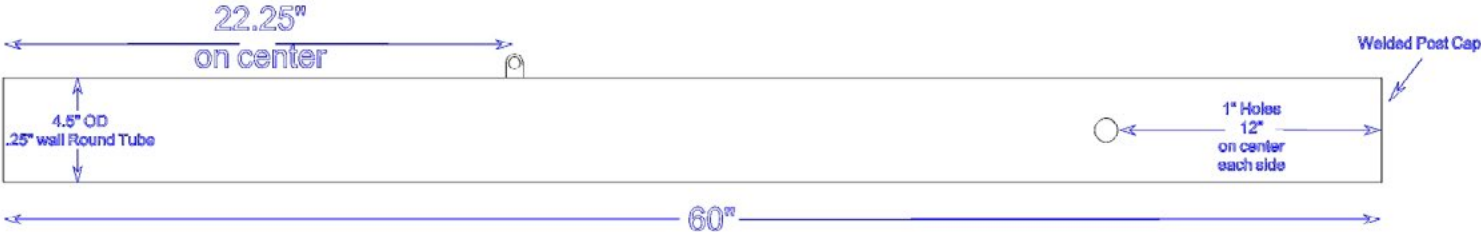

fig. 02d: TYPICAL BOLLARD & RECEIVER
 Security barriers and removable bollards to be cast aluminum painted or powder coated black by Visco.

4.5"x60" Bollard



02-10



fig. 02e: CAMPUS SIGNAGE EXAMPLES

Clockwise from top left: building identification (2), exterior sign, parking identification, pedestrian orientation & messaging kiosk

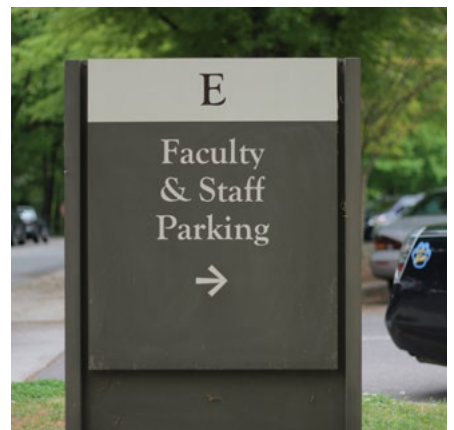

EXISTING CONDITIONS

and Sentinel smart system controls and software shall be specified to allow the University personnel to control the system from the World Wide Web.

Recommend designer review planting layout with WFU Landscaping Services Manager prior to finalizing the design.

02-11

Site Lighting

Site Lighting to be prepared by the designer in accordance with WFU Exterior Lighting Guidelines and Assessment:

<http://facilities.wfu.edu/working-with-us/forms-and-policies/>

All Cobra Street & Parking Lights are to be CREE XSP2L Type III or Type V, in Universal “Silver”.

All new Street Light Poles to be “Black” finish.

All new Acorn Pedestrian Poles to be cast iron, factory prime painted red oxide and finish paint to be applied in the field Paint Color “Black” finish.



fig. 02f: SITE LIGHTING -
ACORN PEDESTRIAN POLE

Concrete

DIVISION 03

Contents

03-02 Materials

03-03 Concrete Mixtures for Building Elements

03-01

Materials

STEEL REINFORCEMENT

- ◆ *Recycled Content of Steel Products: Postconsumer recycled content plus one-half of preconsumer recycled content not less than 25 percent.*
- ◆ *Reinforcing Bars: ASTM A 615, Grade 60, deformed.*
- ◆ *Plain-Steel Welded Wire Reinforcement: ASTM A 185, plain, fabricated from as-drawn steel wire into flat sheets.*

CONCRETE MATERIALS

- ◆ *Portland Cement: ASTM C 150, Type I/II.*
- ◆ *Fly Ash: ASTM C 618, Class F. Limit use 25% by volume.*
- ◆ *Normal-Weight Aggregates: ASTM C 33, coarse aggregate or better, graded.*
- ◆ *Maximum Coarse-Aggregate Size: 3/4 inch nominal.*
- ◆ *Fine Aggregate: Free of materials with deleterious reactivity to alkali in cement.*
- ◆ *Lightweight Aggregate: ASTM C 330, 3/4-inch nominal maximum aggregate size.*
- ◆ *Water: ASTM C 94, potable.*

ADMIXTURES

- ◆ *Air-Entraining Admixture: ASTM C 260.*
- ◆ *Water-Reducing Admixture: ASTM C 494, Type A.*
- ◆ *Retarding Admixture: ASTM C 494, Type B.*
- ◆ *Water-Reducing and Retarding Admixture: ASTM C 494, Type D.*
- ◆ *High-Range, Water-Reducing Admixture: ASTM C 494, Type F.*
- ◆ *High-Range, Water-Reducing and Retarding Admixture: ASTM C 494, Type G.*
- ◆ *Plasticizing and Retarding Admixture: ASTM C 1017, Type II.*

WATERSTOPS

- ◆ *Flexible PVC Waterstops.*
- ◆ *Self-Expanding Butyl Strip Waterstops.*

SHEET VAPOR RETARDER

- ◆ *10 mil, minimum.*

CONCRETE

CURING MATERIALS

- ◆ *Evaporation retarder.*
- ◆ *Moisture-Retaining Cover: ASTM C 171, polyethylene film or white burlap-polyethylene sheet.*
- ◆ *Clear, Waterborne, Membrane-Forming Curing Compound: ASTM C 309, Type 1, Class B, nondissipating, certified by curing compound manufacturer to not interfere with bonding of floor covering.*
- ◆ *Clear, Waterborne, Membrane-Forming Curing and Sealing Compound: ASTM C 1315, Type 1, Class A.*

Concrete Mixtures for Building Elements

FOOTINGS, SLAB ON GRADE

- ◆ *Normal-weight concrete.*
- ◆ *Minimum Compressive Strength: 3000 psi at 28 days.*
- ◆ *Maximum Water-Cementitious Materials Ratio: 0.55.*
- ◆ *Air Content: 2 percent, plus or minus 1.5 percent at point of delivery (prior to pumping).*

FOUNDATION WALLS, BASEMENT WALLS, GRADE BEAMS, AND PILE CAPS

- ◆ *Normal-weight concrete.*
- ◆ *Minimum Compressive Strength: 4000 psi at 28 days.*
- ◆ *Maximum Water-Cementitious Materials Ratio: 0.50.*
- ◆ *Air Content: 2 percent, plus or minus 1.5 percent at point of delivery (prior to pumping).*

SUSPENDED SLABS (NORMAL WEIGHT CONCRETE)

- ◆ *Minimum Compressive Strength: 3000 psi at 28 days.*
- ◆ *Maximum Water-Cementitious Materials Ratio: 0.55.*
- ◆ *Air Content: 2 percent, plus or minus 1.5 percent at point of delivery (prior to pumping). Do not allow air content of trowel-finished floors to exceed 3 percent at point of delivery (prior to pumping).*

SUSPENDED SLABS (LIGHT WEIGHT CONCRETE)

- ◆ *Minimum Compressive Strength: 4000 psi at 28 days.*
- ◆ *Calculated Equilibrium Unit Weight: 115 lb/cu. ft., plus or minus 3 lb/cu. ft. as determined by ASTM C 567.*

- ◆ *Maximum Water-Cementitious Materials Ratio: 0.55.*
- ◆ *Air Content: 3 per cent*

FILL FOR STEEL PAN STAIRS

- ◆ *Minimum Compressive Strength: 2500 psi at 28 days.*
- ◆ *Maximum Water-Cementitious Materials Ratio: 0.65.*
- ◆ *Air Content: 2 percent, plus or minus 1.5 percent at point of delivery (prior to pumping).*
- ◆ *Slump Limit: 4 inches plus or minus 1 inch at point of delivery (prior to pumping).*
- ◆ *Slump Limit for concrete containing high-range water-reducing admixture or plasticizing admixture: 8 inches maximum for concrete with approved design mix slump of 3 to 5 inches before adding high-range water-reducing admixture or plasticizing admixture.*

FIELD QUALITY CONTROL

- ◆ *Testing and Inspecting: Owner will engage a qualified testing and inspecting agency to perform field tests and inspections and prepare test reports.*
- ◆ *Concrete Tests: Testing of composite samples of fresh concrete obtained according to ASTM C 172 shall be performed according to the following requirements:*
 - *Testing Frequency: Obtain composite sample(s) for each day's pour of each concrete mixture exceeding 5 cu. yd per the following:*

Concrete Delivered	Composite Samples Obtained
Less than 5 cubic yards	None
5 cubic yards to 49 cubic yards	1 (take from first load delivered)
50 cubic yards to 100 cubic yards	1
Over 100 cubic yards	1 for each 100 cubic yards or fraction thereof

- *When frequency of testing will provide fewer than five compressive-strength tests for each concrete mixture, testing shall be conducted from at least five randomly selected batches or from each batch if fewer than five are used.*

CONCRETE

03-05

- ◆ *Slump: ASTM C 143; one test at point of placement (back of concrete truck) prior to conveyance by pump, bucket, etc. for each composite sample, but not less than one test for each day's pour of each concrete mixture. Perform additional tests when concrete consistency appears to change.*
- ◆ *Air Content: ASTM C 231, pressure method, for normal-weight concrete; ASTM C 173 volumetric method, for structural light-weight concrete; one test at point of placement (back of concrete truck) prior to conveyance by pump, bucket, etc. for each composite sample, but not less than one test for each day's pour of each concrete mixture.*
- ◆ *Concrete Temperature: ASTM C 1064; one test hourly when air temperature is 40 deg F and below and when 80 deg F and above, and one test for each composite sample.*
- ◆ *Unit Weight: ASTM C 567, fresh unit weight of structural light-weight concrete; one test at point of placement (back of concrete truck) prior to conveyance by pump, bucket, etc. for each composite sample, but not less than one test for each day's pour of each concrete mixture.*
- ◆ *Compression Test Specimens: ASTM C 31.*
 - *Cast and laboratory cure five, 6 inch by 12 inch (or seven 4 inch by 8 inch) standard cylinder specimens for each composite sample.*
- ◆ *Compressive-Strength Tests: ASTM C 39; test one 6 by 12 inch (or one 4 by 8) laboratory-cured specimen at 7 days and two 6 by 12 (or three 4 by 8 inch) laboratory-cured specimens at 28 days and hold two 6 by 12 (or three 4 by 8 inch) laboratory-cured specimens in reserve for 56 day test if required.*
 - *A compressive-strength test shall be the average compressive strength from a set of two specimens obtained from same composite sample and tested at age indicated.*
 - *Strength of each concrete mixture will be satisfactory if every average of any three consecutive compressive-strength tests equals or exceeds specified compressive strength and no compressive-strength test value falls below specified compressive strength by more than 500 psi.*
 - *Test results shall be reported in writing to Architect, concrete manufacturer, and Contractor within 48 hours of testing.*

03-06

Reports of compressive-strength tests shall contain Project identification name and number, date of concrete placement, name of concrete testing and inspecting agency, location of concrete batch in Work, design compressive strength at 28 days, concrete mixture proportions and materials, compressive breaking strength, and type of break for both 7- and 28-day tests.

- ◆ *Measure floor and slab flatness and levelness according to ASTM E 1155 within 24 hours of finishing.*

Contents

04-02 04 0000 – Masonry

04-01

List of Figures

04-04 *fig. 04a: Typical Brick Masonry Cleanout Detail, Section & Elevation*

04 0000 – Masonry

Masonry veneer shall be of clay brick. Do not use other masonry veneers such as concrete masonry, rubble or rock-faced stone masonry, or brick sized units of concrete or materials other than clay.

Clay brick masonry: The campus standard is Old Virginia Brick, hand form series, modular dimension.

Limestone elements of the façade shall be Indiana Limestone matching existing adjacent buildings or other WFU sample. Design and detail stone in accordance with the Indiana Limestone Handbook.

Support and closure of window and door openings may be treated in the following ways:

- ◆ *Limestone surrounds*
- ◆ *Limestone sills*
- ◆ *Cast stone closely matching approved limestone*
- ◆ *Brick jack arch lintels*

Where steel lintels are employed, used Type 304 stainless steel lintels for permanent corrosion resistance. Coat visible portions with high performance paint. Do not use:

- ◆ *Mild steel lintels*
- ◆ *Galvanized lintels*
- ◆ *Precast concrete lintels*
- ◆ *Cast stone lintels*

Where ornament or accent materials are incorporated into brick veneer or into the façade as a whole, limit material to limestone. Do not use:

- ◆ *Simulated stone*
- ◆ *Cast stone*
- ◆ *Concrete units*

Masonry sills shall be constructed of limestone. Do not use:

- ◆ *Brick rowlocks*
- ◆ *Cast-in-place concrete*
- ◆ *Precast concrete*
- ◆ *Cast stone*

MASONRY

Masonry anchors and joint reinforcing materials:

- ◆ *Joint reinforcing for interior CMU: Hot-dip galvanized steel, ASTM A 153 Class B-2.*
- ◆ *Joint reinforcing for exterior CMU back-up where no portion of the metal extends to the exterior side of the weather-resistive membrane: Hot-dip galvanized steel.*
- ◆ *Joint reinforcing for exterior CMU back-up where any portion of the metal extends to the exterior side of the weather-resistive membrane: Type 304 stainless steel.*
- ◆ *Wall ties used in composite or cavity wall construction: Type 304 stainless steel.*
- ◆ *Veneer anchors: Type 304 stainless steel.*
- ◆ *Stone anchors: Type 304 stainless steel.*

Masonry mortar:

- ◆ *ASTM C 270, proportion specification; limit cementitious materials to Portland cement and lime; masonry cement and mortar cement not permitted.*
- ◆ *Mortar color: match color of the adjacent campus buildings or Wait Chapel, as directed by the Office of the University Architect.*
- ◆ *Require volumetric measuring of each material to ensure consistent proportions of each batch. Do not permit the “shovel” method. Do not permit retempering of pigmented mortar.*

Cleanouts, Vents, and Weeps for Masonry Veneer: An essential feature of moisture-resistant veneer construction is a clean, mortar-free air space between the rear face of veneer and back-up or insulation materials. Design veneer to provide a 2-inch-nominal air space and require the use of cleanouts spaced 24 inches on center at each flashing level. **Refer to figure 04a, following page.** Such provisions not only allow the mason adequate clearance to construct a mortar-free cavity and to remove such droppings as do occur, but also allow for the design professional to verify that this has in fact been done. Mesh products in the cavity merely raise the mortar clog upwards in the cavity; do not permit the use of mesh products. In addition to weep devices (Cell-Vent or similar) at 24 inches o.c. along each flashing level, utilize these devices as vents spaced 24 inches o.c. 3 courses or so the top of each panel of veneer so as to provide a convective ventilation path between weeps and vents to ensure rapid drying out of masonry veneer.

04-04

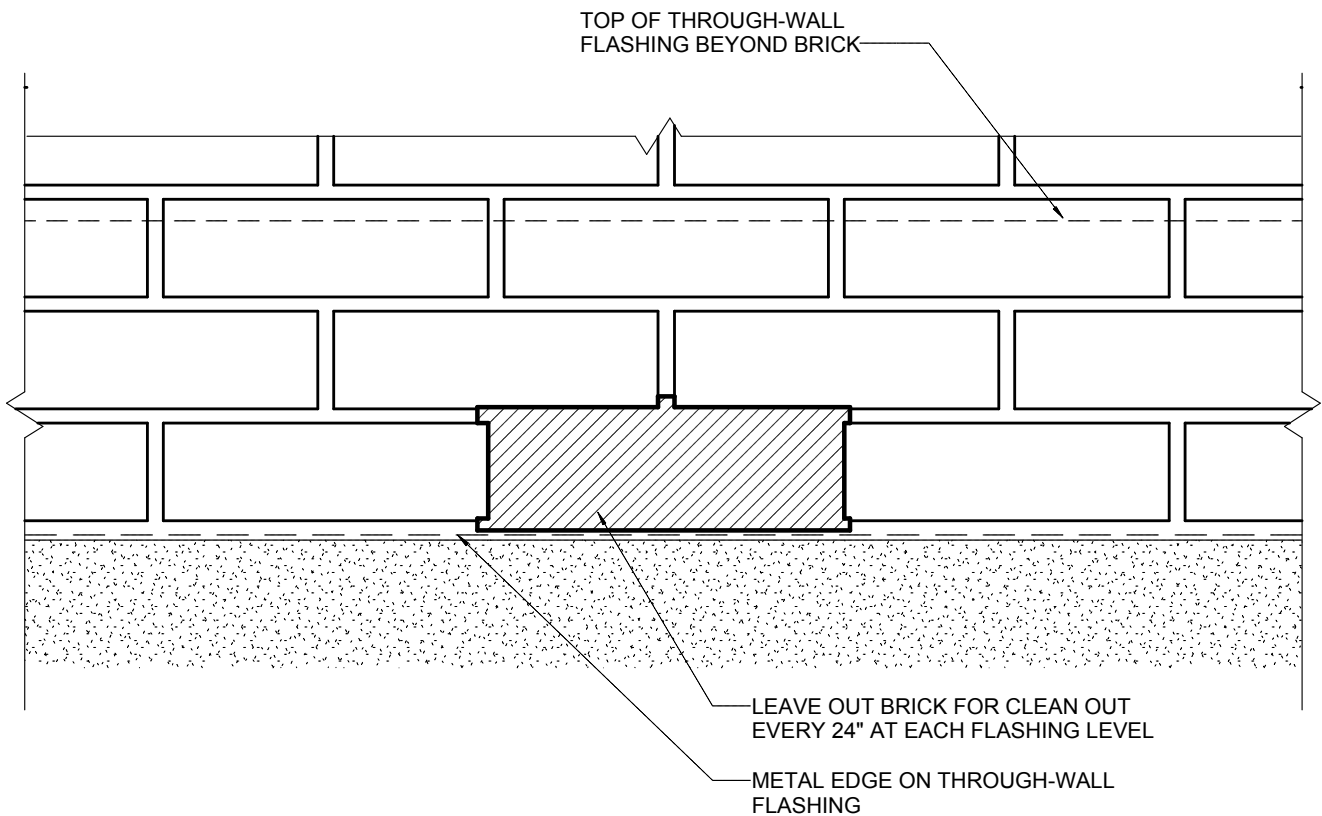
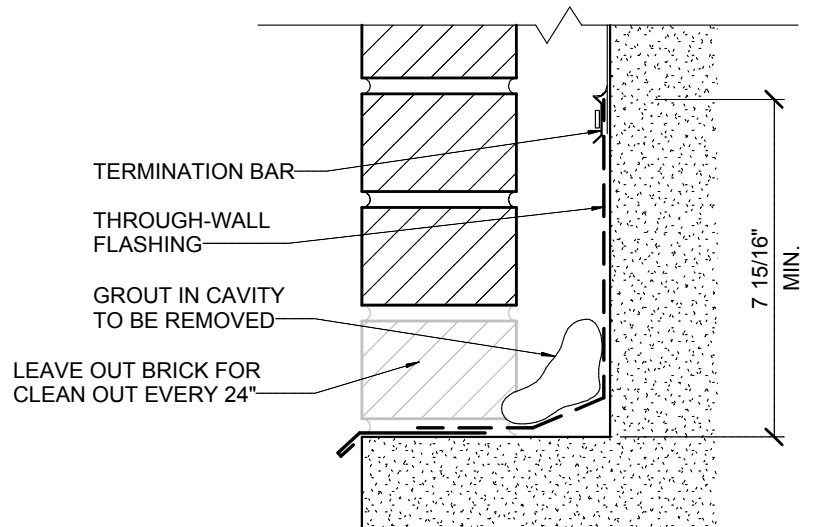

fig. 04a: TYPICAL BRICK MASONRY CLEANOUT DETAIL, SECTION & ELEVATION

Not to scale. Design veneer to provide a 2-inch-nominal air space and require the use of cleanouts spaced 24 inches on center at each flashing level. Such provisions not only allow the mason adequate clearance to construct a mortar-free cavity and to remove such droppings as do occur, but also allow for the design professional to verify that this has in fact been done.

Metals

SUBTITLE

Contents

- 05-02 05 1213 Architecturally Exposed Structural Steel (AESS)
- 05-03 05 5000 Metal Fabrications or Miscellaneous Metals
- 05-04 05 5200 Handrails and Railings
- 05-05 Structural Steel

05-01

List of Figures

- 05-03 *fig. 05a: Tolerance Control Examples*

Division 5 of the contract documents will be a combination of specifications developed and written by the project engineer and the project architect. With the possible exception of handrails or decorative metals, the composition and review of all sections in this division should be developed jointly between both disciplines.

05 1213 Architecturally Exposed Structural Steel (AESS)

The AESS specification should be limited to structural steel that is intended to be exposed as a key aspect of the design and therein requires a significantly higher level of finish and tighter construction tolerances. AESS has significant cost implications for the structural budget of a project. The designer should review the range of finish and tolerances to be expected with WFU compared to a cost matrix to ascertain the level of AESS and scope for each project.

05-02

SUMMARY

- ◆ *The AESS specification should be written in conjunction with the Structural Steel specification.*
- ◆ *The AESS specification will focus on the appearance and surface preparation of the steel.*
- ◆ *Carefully evaluate and specify the level of AESS necessary to achieve the desired aesthetic effect. Do not over-specify the level of AESS.*
- ◆ *Documents shall clearly indicate what is AESS and what is not AESS.*
- ◆ *Submittals are a key component to ensure the intent in the design is understood by the Contractor and fabricator and shall include class of surface preparation, indicate what is exposed and what is not, indicate and demonstrate in the form of samples joint finishing for grinding, contouring and blending etc. as required by the design.*
- ◆ *The expertise of the fabricator is a key component in ensuring the appropriate understanding and resulting care is given to this scope of work. The project should require that fabricator and contractor/erector demonstrate at least 5 successful projects of similar complexity and scope to the project for which this section is used. This documentation should include examples of shop drawings, pictures of finished work and Owner/Designer references for follow up by the project designer.*
- ◆ *Mockups are expensive, but are indispensable in ensuring the quality of materials, fabrication and installation and shall be required for this scope of work.*

METALS

FABRICATION AND ERECTION

- ◆ For best results, components and assemblies should be shop fabricated and every effort should be made to conceal field-made connections.
- ◆ Surfaces should be prepared only after the mock-up is accepted and shall be prepared consistent with the approved mock-up.
- ◆ Tolerances are governed by AESS standards. Refer to figure for examples of tolerance controls.

05-03

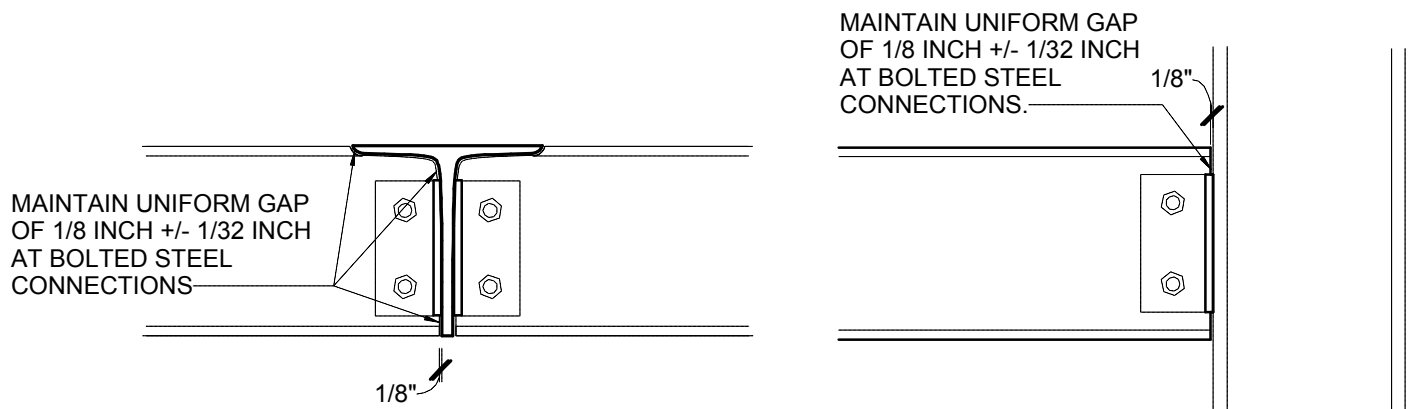

fig. 05a: TOLERANCE CONTROL EXAMPLES
Tolerances are governed by AESS standards.

FINISHING

- ◆ Shop and field preparation shall be specified according to the Society for Protective Coatings (SSPC):
 - SSPC-SP 1 = Solvent Cleaning
 - SSPC-SP 2 = Hand Tool Cleaning
 - SSPC-SP 3 = Power Tool Cleaning
 - SSPC-SP 6 = Commercial Blast Cleaning
- ◆ Steel shall be shop primed immediately following surface preparation. This section should limit finish content to the primer to be used in the manufacture/fabrication of the steel for AESS. Primers must be carefully coordinated with the division 9 top coats or finish coats to be applied to the material.

05 5000 Metal Fabrications or Miscellaneous Metals

TYPICAL ASSEMBLIES TO WHICH THIS SECTION PERTAINS:

- ◆ *Shop fabricated steel and aluminum items including but not limited to ladders, bumper posts and guard rails, bollards, miscellaneous lintels, ledge angles, shelf angles, door frames for overhead door openings, supplemental framing for louvered openings, and miscellaneous mounting supports. Gates may be specified here, in handrails and railings or in metal stairs depending on how they are used.*

CONSIDERATIONS

- ◆ *Prefabricated/ manufactured ladders may be specified here or in divisions 10 or 11.*
- ◆ *For all ladder designs, OSHA and Department of Labor requirements must be addressed.*
- ◆ *All steel items should be shop primed or galvanized and must be coordinated with finish/top coats specified in Division 9.*
- ◆ *The project structural engineer should be consulted on all items in this section.*

05 5200 Handrails and Railings

TYPICAL ASSEMBLIES TO WHICH THIS SECTION PERTAINS:

- ◆ *Primed and painted steel railings, galvanized steel exterior railings, aluminum railings, stainless steel railings, removable rails, and gates. Manufactured railing systems may also be specified in this section or in an ornamental metals section.*

DESIGN REQUIREMENTS

- ◆ *Handrails and railings must meet the height, loading requirements and opening allowances as prescribed in the North Carolina Building Code.*
- ◆ *ADA/ANSI requirements for accessibility must be addressed along all accessible routes.*

SUMMARY

- ◆ *Shop/ fabrication drawings are essential.*

METALS

- ◆ *For custom/ornamental railing assemblies, mock-ups are always required and should be specified to confirm the design intent is understood and met, that finishes are acceptable and fit and finish of the assembly is what was specified.*
- ◆ *Expectations for fit and finish must be clearly specified. Similar to Architecturally Exposed Structural Steel, tolerances for these assemblies are much tighter than is normally expected for a miscellaneous metal assembly.*
- ◆ *All parts and pieces of the assemblies, including hardware, must be clearly identified on the drawings or in the specifications.*

05-05

FINISHES

- ◆ *Shop and field preparation shall be specified according to the Society for Protective Coatings (SSPC) specifications:*
 - *SSPC-SP 1 = Solvent Cleaning*
 - *SSPC-SP 2 = Hand Tool Cleaning*
 - *SSPC-SP 3 = Power Tool Cleaning*
 - *SSPC-SP 6 = Commercial Blast Cleaning*
- ◆ *Steel should be shop primed immediately following the above noted surface preparation. This section should limit finish content to the primer to be used in the manufacture/fabrication of the steel. Primers must be carefully coordinated with the division 9 top coats or finish coats to be applied to the material.*
- ◆ *Aluminum shall be specified to have a class 1 anodized or fluoropolymer finish.*

Structural Steel

Comply with applicable provisions of the following specifications and documents:

- ◆ *AISC's "Code of Standard Practice for Steel Buildings and Bridges."*
- ◆ *AISC's "Seismic Provisions for Structural Steel Buildings."*
- ◆ *AISC's "Specification for Structural Steel Buildings."*
- ◆ *AISC's "Specification for the Design of Steel Hollow Structural Sections."*
- ◆ *RCSC's "Specification for Structural Joints Using ASTM A 325 or A 490 Bolts."*

Provide the following minimum requirements on the Contract Documents:

- ◆ *Dimensioned framing plans to all structural steel elements, provide edge of slab dimensions, edge of roof deck dimensions.*
- ◆ *Provide all necessary details that will specify miscellaneous steel requirements to support loads from building elements attached to structure.*
- ◆ *Specify camber and beam reactions for composite steel framing.*
- ◆ *Provide details of connections required by the Contract Documents to be selected or completed by structural-steel fabricator to withstand service loads indicated and comply with other information and restrictions indicated.*

LEED SUBMITTALS

- ◆ *Product Data for Credit MR 4: For products having recycled content, documentation indicating percentages by weight of post-consumer and pre-consumer recycled content. Include statement indicating cost for each product having recycled content.*
- ◆ *Laboratory Test Reports for Credit IEQ 4: For primers, documentation indicating that products comply with the testing and product requirements of the California Department of Health Services' "Standard Practice for the Testing of Volatile Organic Emissions from Various Sources Using Small-Scale Environmental Chambers."*

STRUCTURAL-STEEL MATERIALS

- ◆ *Recycled Content of Steel Products: Postconsumer recycled content plus one-half of pre-consumer recycled content not less than 50 percent.*
- ◆ *W-Shapes: ASTM A 992.*
- ◆ *Channels, Angles: ASTM A 36.*
- ◆ *Plate and Bar: ASTM A 572, Grade 50 or ASTM A 36.*
- ◆ *Cold-Formed Hollow Structural Sections: ASTM A 500, Grade B, structural tubing.*
- ◆ *Steel Pipe: ASTM A 53, Type E or S, Grade B.*
- ◆ *Welding Electrodes: Comply with AWS requirements.*

BOLTS, CONNECTORS, AND ANCHORS

- ◆ *If corrosion-resisting (weathering) steel is used, change Type 1 bolts to Type 3 in paragraph below and delete "Finish" Subparagraph.*

METALS

Indicate locations if using bolts below for some connections and ASTM A 490 (ASTM A 490M) bolts for others.

- ◆ *High-Strength Bolts, Nuts, and Washers: ASTM A 325, Type 1, heavy hex steel structural bolts; ASTM A 563 heavy hex carbon-steel nuts; and ASTM F 436 hardened carbon-steel washers.*
- ◆ *High-Strength Bolts, Nuts, and Washers: ASTM A 490, Type 1, heavy hex steel structural bolts; ASTM A 563 heavy hex carbon-steel nuts; and ASTM F 436 hardened carbon-steel washers, plain.*
- ◆ *Shear Connectors: ASTM A 108, Grades 1015 through 1020, headed-stud type, cold-finished carbon steel; AWS D1.1, Type B.*
- ◆ *Unheaded Anchor Rods: ASTM F 1554, Grade 36.*
- ◆ *Headed Anchor Rods/Thru Bolts: ASTM A 307, Grade A, straight.*
- ◆ *Threaded Rods: ASTM A 36.*

05-07

STRUCTURAL STEEL BAR JOISTS

- ◆ *Specify type of joist as follows:*
 - *K-series,*
 - *KCS-series*
 - *Long span joist*
- ◆ *Specify loading requirements. Where appropriate for complex loading such as concentrated hanging loads, provide loading diagram.*
- ◆ *Specify joist seat depths.*

STEEL DECKING

Roof Deck

- ◆ *Deck shall be galvanized.*
- ◆ *Specify depth and gauge of deck.*
- ◆ *Specify attachments to structural members using screws or puddle welds.*
- ◆ *Specify sidelap attachment requirements using screws or puddle welds.*

Floor deck

- ◆ *Deck shall be galvanized.*
- ◆ *Specify depth and gauge of deck.*
- ◆ *Specify attachments to structural members using puddle welds.*
- ◆ *Specify sidelap attachment requirements using screws or puddle welds.*
- ◆ *Use composite floor deck and composite steel construction for all structural steel buildings.*

SHOP PRIMING

Shop prime steel surfaces except the following:

- ◆ *Surfaces embedded in concrete or mortar. Extend priming of partially embedded members to a depth of 2 inches.*
- ◆ *Surfaces to be field welded.*
- ◆ *Surfaces to be high-strength bolted with slip-critical connections.*
- ◆ *Surfaces to receive sprayed fire-resistive materials.*

GALVANIZING

- ◆ *Galvanize exposed steel.*

FIELD QUALITY CONTROL

- ◆ *Testing Agency: Owner will engage a qualified independent testing and inspecting agency to inspect field welds and high-strength bolted connections.*
- ◆ *RCSC prescribes inspection for snug-tightened joints and testing and inspection for each method of pretensioning joints.*

Contents

- 06-02 06 1000 – Rough Carpentry (Backboards, Nailers and Blocking)
- 06-03 06 1600 – Sheathing
- 06-04 06 4100 – Custom Cabinets and Woodwork

List of Figures

- 04-08 *fig. 01a: Figure Title*
- 04-08 *fig. 01b: Figure Title*
- 04-09 *fig. 01c: Figure Title*
- 04-09 *fig. 01d: Figure Title*

In general, Wake Forest University intends to build robust, long lasting buildings that require a reasonable amount of maintenance. To that end stick built wood construction is not appropriate for most renovation and new construction work at the University. Therefore wood frame construction will not be part of these guidelines. Variance from masonry, steel frame or light gauge steel construction must be obtained from the office of Facilities and Campus Services. This section is limited to basic miscellaneous carpentry associated with non-combustible institutional construction. As is typical with non-combustible construction, specifications shall require that all lumber and construction panels shall be fire retardant or preservative treated, or both.

06 1000 – Rough Carpentry (Backboards, Nailers and Blocking)

TYPICAL ASSEMBLIES TO WHICH THIS SECTION PERTAINS:

Roofing nailers and curbs, roofing cants, blocking in wall openings for shims and nailers, in-wall blocking for wall mounted elements, blocking for finished wood trim, telephone and electrical panel backers

REQUIREMENTS

- ◆ *Each piece of lumber or construction panel shall be conspicuously labeled showing compliance with specific wood treatment standards.*
- ◆ *Miscellaneous lumber shall be surfaced four sides (S4S), No. 2 or Standard grade.*
- ◆ *Concealed construction panels may be C-C plugged, exterior grade, PS 1.*
- ◆ *Exposed construction panels shall be A-D exterior grade, PS 1.*
- ◆ *Electrical or Telephone backers shall be A-D interior grade, APA rated sheathing, Exposure 1, PS 1.*
- ◆ *All wood materials shall have a moisture content (kiln dried) of less than 15 percent.*
- ◆ *Fasteners for interior non treated wood may be steel.*
- ◆ *Fasteners for all interior treated wood shall be ASTM A 153 hot-dip dipped galvanized steel fasteners. Stainless steel is also acceptable.*
- ◆ *Fasteners for all exterior wood or wood in exterior assemblies shall be stainless steel without exception.*

WOOD, PLASTICS & COMPOSITES**06 1600 – Sheathing****TYPICAL ASSEMBLIES TO WHICH THIS SECTION PERTAINS:**

Exterior gypsum board sheathing, cement board sheathing, wood construction panel sheathing.

Specify joint treatment specific to the weather resistant barrier system per Division 7. NOTE that the 2012 IBC and NFPA 268 places new restrictions on flame spread and smoke development in these assemblies when installed in Types I, II, III and IV construction.

GYPSUM BOARD SHEATHING

Fiberglass Faced Gypsum Sheathing shall conform to ASTM C 177.

- ◆ *Core: Water-resistant fiberglass mat front and back*
- ◆ *Noncombustible per ASTM E 84.*
- ◆ *Flame spread and smoke developed: ASTM E 84; 0 and 0 values.*
- ◆ *Thickness: 5/8 inch or 3/4 inch*

CEMENT BOARD SHEATHING

Wood Cement Sheathing Panels: cement bonded particle board composed of mineralized wood particles and Portland cement.

Noncombustible per ASTM E 84.

FASTENERS

Screws: ASTM C 1002; self-drilling type, cadmium-plated.

Gypsum Board Sheathing:

- ◆ *Fasteners for fastening gypsum board sheathing to metal framing: 12-22 gage steel framing: Type S fine thread, rust resistant, drill point dry wall screws.*
- ◆ *Length: minimum 1 1/4 inch, #6 for 5/8 inch and 1/2 inch thick sheathing.*

Cement Board Sheathing:

- ◆ *Fasteners for attaching cement board sheathing to metal framing: Self-drilling, self-tapping router head screws; countersunk heads.*
- ◆ *Sized to fully penetrate framing.*
- ◆ *Material: Type 304 Stainless Steel heads and shanks, fused carbon steel drill tips.*

JOINT TREATMENT

Exterior Soffits and Ceilings:

- ◆ *Finish joints within gypsum panels in accordance with ASTM C840, Level 5 with a full skim coat.*
- ◆ *Tape, fill, and sand exposed joints, edges and corners to produce smooth surfaces ready to receive finishes.*

06 4100 – Custom Cabinets and Woodwork**06-04****TYPICAL ASSEMBLIES TO WHICH THIS SECTION PERTAINS:**

Plastic Laminate Cabinets, Wood Veneer Cabinets, Standing and Running Trim, Cabinet Hardware and Top Mounted Sinks.

For countertops, refer to Division 12 guidelines.

QUALITY ASSURANCE

Work under this section shall be specified to be provided by a company specializing in the manufacture of these products with a minimum of three years of documented experience.

Manufacturer Qualifications: Manufacturer shall be a member in good standing of the Architectural Woodwork Institute (AWI)

WOOD MATERIALS

Hardwood Lumber: NHLA: Graded in accordance with AWI, average moisture content of 5-10 percent.

- ◆ *Minimum grade: AA*

PANEL MATERIALS

- ◆ *Hardwood faced plywood: HPVA HP-1; graded in accordance with AWI/AWMAC*
- ◆ *Face Veneer: Minimum grade, AA for exposed and semi-exposed surfaces.*
- ◆ *Core for completely dry spaces where humidity and moisture or leaks are not a concern: particle board or medium density fiberboard may be used if approved in writing by WFU.*
- ◆ *Core in toilet rooms, kitchens and other areas where humidity or water is a concern: real wood plywood shall be provided.*
- ◆ *Particleboard: ANSI A208.1; medium density industrial type, composed of wood chips bonded to interior grade adhesive under*

WOOD, PLASTICS & COMPOSITES

heat and pressure; sanded faces; thickness as required.

- ◆ *Medium Density Fiberboard (MDF): ANSI A208.2; composed of wood fibers pressure bonded with moisture resistant adhesive to suit application; sanded faces; thickness as required.*

LAMINATE MATERIALS

High Pressure Decorative Laminate (HPDL): NEMA LD 3, types as recommended for specific applications as follows:

- ◆ *Exposed surfaces: HGS, 0.048 inch nominal thickness, through color.*
- ◆ *Cabinet Liner: CLS, 0.020 inch nominal thickness, through color.*
- ◆ *Laminate Backer: BKL, 0.020 inch nominal thickness, undecorated; to be applied to concealed backside of panels faced with high pressure decorative laminate. This is necessary for balanced panel construction.*

06-05

ACCESSORIES

Grommets: Standard plastic, painted metal or rubber grommets for cut-outs. All cut-outs through which cabling is intended to pass shall be covered in a grommet.

HARDWARE

Hardware is project specific and may be dictated by the University's desire to match existing.

Minimum Hardware requirements:

- ◆ *Drawer Slides: Medium/Heavy Duty for drawers 30 inches wide or less and must accommodate a minimum load bearing capacity of 100 pounds. Slides shall all be full-extension, hold-in detent, with 1 inch over travel.*
- ◆ *Drawer Slides: Heavy Duty for drawers up to 42 inches wide and shall have a minimum load bearing capacity of 150 pounds. Slides shall all be full-extension, hold-in detent, with 1 inch over travel. Guides are to be epoxy coated in laboratory environments.*

STANDING AND RUNNING TRIM

- ◆ *The grade of the work must be specified. The AWI standards provide three grades of work, premium, custom and economy.*
- ◆ *Most work at Wake Forest University will be Custom grade.*
- ◆ *Premium grade shall only be specified when authorized by the*

Office of the University Architect and will be reserved for very rare installations of woodwork.

- ◆ *Joints in continuous standing trim elements are not permitted.*
- ◆ *Joints in continuous running trim must be scarfed and are not allowed in runs less than 6 feet in length.*

Thermal and Moisture Protection

DIVISION 07

Campus Design Guidelines

Contents

- 07-02 07 1010 – Below-Grade Waterproofing
- 07-02 07 1020 – Traffic-Bearing Waterproofed Decks, Balconies, and Plazas
- 07-03 07 2100 – Exterior Wall Thermal Insulation
- 07-04 07 2500 – Weather-Resistant Barriers
- 07-05 07 2614 – Above-Slab Vapor Retarders
- 07-06 07 2617 – Under-Slab Vapor Retarders
- 07-06 07 3000 – Steep Slope Roofing
- 07-07 07 5000 – Membrane Roofing
- 07-08 07 6000 – Sheet Metal Work
- 07-10 07 8100 – Spray-Applied Fireproofing for Concealed Interior Locations
- 07-11 07 9200 – Joint Sealers

07-01

List of Figures

- 07-08 *fig. 07b: Two-piece Flashing*
- 07-10 *fig. 07a: Typical Joint Sealer Details*

07 1010 – Below-Grade Waterproofing

Elevator pits, vaults, sumps, and similar construction: Acceptable product: Xypex admix (added to concrete batch) with Xypex slurry applied to the interior surface of the construction after stripping of formwork.

Basement construction, waterproofing applied to the exterior surface of basement walls: Use either hot-fluid-applied SEBS-rubberized asphalt or cold fluid-applied waterproofing (thickness as listed).

07.1 Acceptable hot-applied products: Reinforced assembly, 215 mils thick.

07.1.1 American Hydrotech, Inc.; Monolithic Membrane 6125; www.hydrotechusa.com.

07.1.2 Henry Company; Elasto-Seal 790-11; www.Henry.com.

07.1.3 Tremco, Inc.; Tremproof 6100.

07.2 Acceptable cold-applied products: Reinforced assembly. Mil thickness stated below does not include the thickness of the protection course / separation sheet.

07.2.1 Henry Company; Elasto-Seal CM100 High Build reinforced membrane; 110 mils wet, 107 mils dry; Henry Polyester Fabric reinforcement; ModifiedPlus G100s/s.

07.2.2 Tremco, Inc.; Tremproof 250 GC reinforced system; 180 mils wet, 155 mils dry; Tremco Remay reinforcement; Tremco Protection Mat.

07.2.3 W.R. Grace; Procor 3R Waterproofing System plus Composite Sheet fully adhered as a protection course / separation sheet; membrane thickness (excluding composite sheet) 120 mils wet and dry; Procor Composite Sheet.

Basement slab construction where ground water conditions indicate a need for under-slab waterproofing: Tremco, Inc.; Paraseal Membrane.

07 1020 – Traffic-Bearing Waterproofed Decks, Balconies, and Plazas

Where horizontal surfaces will be subjected to foot traffic (other than occasional maintenance traffic) in addition to weather, use either hot-fluid-applied SEBS-rubberized asphalt or cold-fluid-applied polyester waterproofing. Cover asphalt waterproofing with pavers. Cover polyester waterproofing with surfacing approved by the manufacturer. Such surfaces may also be covered with soil and

THERMAL AND MOISTURE PROTECTION

vegetation (so-called green roofs) when incorporated into the approved building program. Incorporate thermal insulation and drainage as appropriate for the assembly.

07.3 Acceptable hot-applied products: Reinforced assembly, 215 mils thick.

07.3.1 American Hydrotech, Inc.; Monolithic Membrane 6125; www.hydrotechusa.com.

07.3.2 Henry Company; Elasto-Seal 790-11: www.Henry.com.

07.3.3 Tremco, Inc.; Tremproof 6100.

07.4 Acceptable polyester products:

07.4.1 Kemper; Kemperol V210/V210M, BR/BRM; 70 mils thick.

07-03

07 2100 – Exterior Wall Thermal Insulation

Design the thermal wall envelope as a continuous element without thermal bridges insofar as practicable, uniting the thermal wall insulation with that of roofs, soffits, and other envelope surfaces.

Ensure that deleterious condensation does not form inside of wall assemblies.

Continuous Insulation under Brick Veneer: Use any of the following, applied at a thickness to achieve at least R-13, and in no case less than required by the Energy Code:

- ◆ *Extruded polystyrene foam plastic board insulation in the masonry cavity on face of sheathed stud or masonry back-up.*
- ◆ *Polyisocyanurate foam plastic board insulation on face of sheathed stud or mineral wool (rock or slag) board insulation on face of sheathed stud.*
- ◆ *Sprayed-in-place foam plastic insulation in steel stud cavities when exterior sheathing is installed on exterior furring strips applied perpendicular to steel studs.*

Insulation in Stud Cavities in Combination with Continuous Insulation on the Face of Sheathing: Mineral wool (rock or slag) batt insulation may be placed in stud cavities to the full height and full depth of the wall to completely fill the stud cavities provided it is accompanied by the use any of the following insulation materials applied at a thickness to achieve at least R-13:

- ◆ *Extruded polystyrene foam plastic board insulation on face of sheathed stud or masonry back-up.*

- ◆ *Polyisocyanurate foam plastic board insulation on face of sheathed stud, or mineral wool (rock or slag) rigid board insulation on face of sheathed stud.*

Assemblies that employ batt insulation shall be evaluated by the Architect using current hygro-thermal modeling analysis to ensure that deleterious condensation does not form in the assembly.

Do not use: Batt insulation in metal stud cavities without a layer of continuous insulation as described above.

Assemblies that use foam plastic insulation shall be subject to the limitations contained in the Code.

07-04

07 2500 – Weather-Resistant Barriers

Provide a continuous weather barrier and air barrier over the exterior skin, typically located on the exterior surface of CMU or sheathing.

Where a vapor retarder is required, use the vapor retarder as an air barrier.

- 07.5 Air Barrier / vapor permeable type, where a vapor barrier is neither required nor desirable:
 - 07.5.1 Prosoco CAT-5.
 - 07.5.2 W.R. Grace Perm-A-Barrier VP.
 - 07.5.3 Henry Air-Bloc 31 or 33.
 - 07.5.4 DuPont Tyvek Liquid.
- 07.6 Air/Vapor Barrier, where a vapor barrier is required or permitted:
 - 07.6.1 On masonry back-up: Either bituminous damproofing ASTM D 1227, Type II, two coats applied pin-hole-free, not less than 60 dry mils total thickness or impermeable liquid-applied modified bituminous wall membrane by W.R. Grace, Henry, or W.R. Meadows.
 - 07.6.2 On stud and sheathing back-up: Self-adhesive modified bituminous sheet wall membrane over primer, or impermeable liquid-applied modified bituminous wall membrane. Products by W.R. Grace, Henry, or W.R. Meadows.

THERMAL AND MOISTURE PROTECTION

Cladding fastener penetrations of liquid-applied barriers can be sources of water penetration into stud and sheathing back-up. Most manufacturers either recommend or require that cladding fasteners be detailed with one of a variety of techniques such as an extra detail coating of liquid, a “patch” of self-adhesive sheet membrane under each masonry veneer anchor, a strip of self-adhesive sheet membrane applied continuously to each stud, daubing around fastener penetrations with compatible sealant, etc. A few products have been demonstrated to be self-sealing and tested to resist water penetration without such detailing. Where liquid-applied products are used, require detailing of each cladding fastener penetration unless test reports of the specified product demonstrate adequate sealing properties.

The University discourages the use of “house wrap”, and its use is not permitted unless approved by the Office of the University Architect. When permitted, use only DuPont Tyvek Commercial Wrap along with DuPont fasteners, flashings, and approved accessories.

Foamed-in-place insulation, of suitable perm rating and moisture resistance, may also be considered on a case-by-case basis.

Select, design, and detail each of the above to form a weather-resistant barrier to guard against the ingress of liquid moisture into the wall assembly. Ensure that the weather-resistant barrier on walls is effectively tied into and made continuous with windows, doors, and other penetrations, roof assembly air barrier / water barrier, and damproofing or waterproofing at grade.

07 2614 – **Above-Slab Vapor Retarders**

When renovating existing construction, evaluate the need for vapor control on existing concrete slabs on grade. Although resilient flooring set in traditional mastic may have performed well, when removed and replaced with new flooring set in new adhesive formulations it may not perform adequately. Evaluate the need for vapor pressure remediation. When practicable include field testing during the design / demolition phase prior to finalizing construction documents and construction price. If the project schedule does not allow for design phase testing, on the bid form, identify vapor control as an alternate with a firm price subject to the owner’s acceptance prior to flooring installation, then perform field testing during the construction phase. Test in accordance with ASTM F2170. Vapor control products for application above slab are available in a wide variety of material quality, reliability, and cost – many of which are unsuitable for WFU construction; offerings are continuously evolving in the market place. Acceptable products include osmotic pressure relief grout and epoxy barrier coatings by Koester and Ardex.

07 2617 – Under-Slab Vapor Retarders

Provide permanent water vapor barrier beneath floors on grade.

- ◆ *ASTM E 1745, Class A, polyolefin or polyethylene sheet.*
- ◆ *Thickness: 15 mils.*
- ◆ *Puncture Resistance per ASTM D-1709B: Not less than 3100 grams.*
- ◆ *Water Vapor Permeance: Not greater than 0.025 perms.*
- ◆ *Seal joints between vapor retarder elements, penetrations, and perimeter*

07 3000 – Steep Slope Roofing

Steep Sloped Roof Coverings: Use one of the following:

- ◆ *Slate shingles – at least 4:12 pitch; design in accordance with the recommendations of Slate Roofs Design and Installation Manual, National Slate Association, 2010.*
- ◆ *Metal roofing: Copper, field-formed standing seam, at least 3:12 pitch; design in accordance with the recommendations of Copper Development Association and Revere. See additional requirements under Sheet Metal Work section.*

Do not use:

- ◆ *Snap-type metal roofing.*
- ◆ *Galvanized or Gavannealed metal roofing with or without a coating.*
- ◆ *Mineral-fiber, plastic, composite, or otherwise manufactured slates or tiles or shingles.*
- ◆ *Asphalt shingles.*
- ◆ *Other roof coverings without written approval.*

Provide a continuous air barrier / secondary water barrier underneath of roof covering, and seal to ensure continuity of barrier with wall air barriers. Barrier shall be butyl rubber with polyethylene facer, not less than 40 mils thick; W.R. Grace Ultra.

Sloped Roof Insulation: 3 inches polyisocyanurate insulation or more if required by the Energy Code plus nailbase sheathing. Install on top of roof deck. Do not place insulation under roof deck; exception: sprayed-in-place foam insulation may be considered on a case-by-case basis.

THERMAL AND MOISTURE PROTECTION

07 5000 – Membrane Roofing

Provide permanent access to all areas of the roof in the form of stairs or fixed ladders and access doors or roof hatches.

Arrange access controls to prevent unauthorized access.

Provide access to roof-top equipment without the need for OSHA-compliant fall-restraint harnesses and devices. All rooftop equipment to be positioned on curbs or raised support frames. Curbs shall be a minimum of 10 inches above adjacent roof surfaces.

Low Slope Roofs: Use one of the following roofing systems:

- ◆ *Conventionally insulated roof: 2 layers of rigid or semi-rigid board insulation, cover board, PVC membrane; all layers of board and membrane fully adhered.*
- ◆ *IRMA/PRMA insulated roof: PVC single ply waterproofing grade membrane or SEBS-hot-fluid-applied rubberized asphalt roofing; 2 layers of 2-inch-thick extruded polystyrene insulation board, top layer Fin-pan LightGuard or CoolGuard surfaced or roofing pavers. Aggregate ballast not permitted.*
- ◆ *Warranty: Membrane manufacturer's non-prorated NDL (no-dollar-limit) material and workmanship 20-year guarantee covering membrane, insulation, roof edge metal, and surfacing.*

Green Roofs: See Section 07 1020 – Traffic-Bearing Waterproofed Decks, Balconies, And Plazas

PVC single ply membrane; use one of the following:

- ◆ *Seaman Corporation. Fibertite 50XT-FB; 50 mil thick; fully adhered.*
- ◆ *Sarnafil. Specification G410 Feltback Energy Smart; 80 mil thick; fully adhered.*
- ◆ *SEBS-hot-fluid-applied rubberized asphalt membrane not less than 215 mils thick, reinforced. Use one of the following:*
- ◆ *American Hydrotech, Inc.; Monolithic Membrane 6125; www.hydrotechusa.com.*
- ◆ *Henry Company; Elasto-Seal 790-11; www.Henry.com.*
- ◆ *Tremco, Inc.; Tremproof 150.*

07 6000 – Sheet Metal Work

In every case, it is essential that flashing design, material, and workmanship last the life of the material with which the flashing is associated.

Flashings associated with sheet metal roofing: See Steep Slope Roofing section.

Flashings associated with slate roofing: Limit flashings to stainless steel or copper. In order to avoid the all-too-common event of flashings that do not last the life of the slate, employ one gage thicker than typical industry standard for each specific application.

Flashings associated with low-slope roofing: Type 304 stainless steel or copper. Design flashings to permit removal and reinstallation of cap flashings for inspection, repair, and replacement of underlying roofing materials while salvaging flashing intact. Provide 2-piece receiver and counterflashing; fasten counterflashing with dome-head screws with neoprene washers, snap-type flashings not permitted. *Refer to fig. 07b below.*

07-08

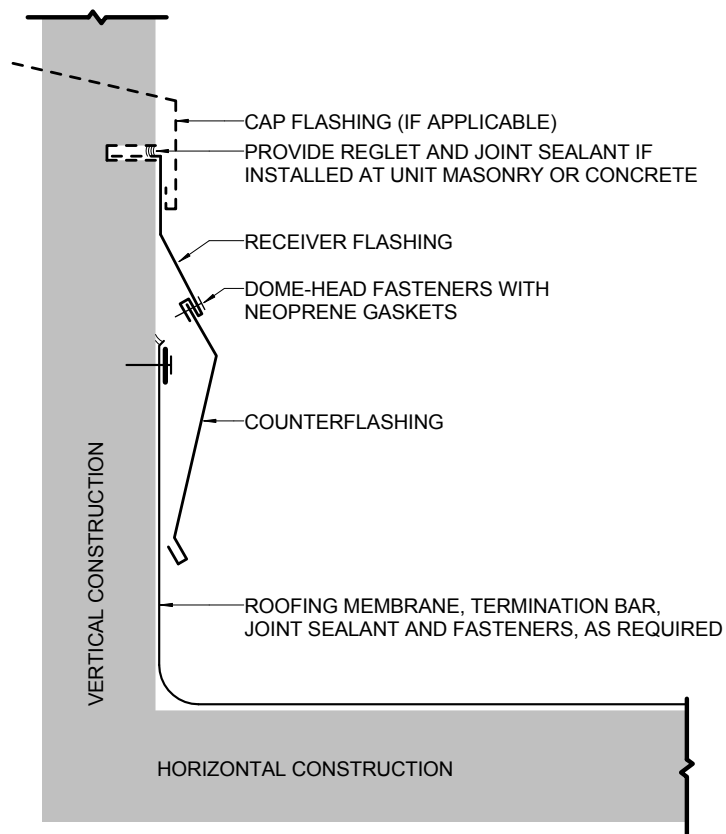

fig. 07b: TWO-PIECE FLASHING
Provide 2-piece receiver and counterflashing; fasten counterflashing with dome-head screws with neoprene washers, snap-type flashings not permitted.

THERMAL AND MOISTURE PROTECTION

Flashings associated with cladding and openings in cladding: Use one or more of the following:

- ◆ *Type 304 stainless steel*
- ◆ *Copper*
- ◆ *Self-adhesive sheet flashing by W.R. Grace, Henry, or W.R. Meadows. At masonry construction provide stainless steel metal drip edge.*
- ◆ *York stainless steel laminated flashing*

Do not use:

- ◆ *Galvanized steel flashing.*
- ◆ *Plastic flashing.*

In addition to other acceptable materials for the respective applications, lead flashing may be employed in the customary situations where malleability is an important criteria. Kynar or Hylar coated aluminum flashing may be employed when associated with Kynar or Hylar coated aluminum fabrications except where other considerations preclude its use such as when in contact with concrete or masonry or where the metal needs to be soldered.

Steep slope sheet metal roofing, gutters, gutter liners, conductor heads, and downspouts – Design criteria:

- ◆ *Design these elements to serve for the life of the roofing installation.*
- ◆ *Wherever practicable, design so that these elements can be repaired or replaced if necessary without disturbing adjacent materials.*
- ◆ *Both concealed and applied gutters shall be designed so that in the event of a leak, water is conducted towards the exterior of the façade without penetrating into the cladding and without entering the building.*
- ◆ *While it is customary and indeed desirable to leave certain fabrication details to the sheet metal craftsman, provide detailed requirements for fabrication in the drawings and specifications; reliance on statements such as “comply with SMACNA” are not adequate for the first-class work required. Indicate in the drawings and specification the specific details required. Strictly observe industry guidelines when developing drawings and specifications for sheet metal work, in particular those authored by Revere or by the Copper Development Association.*
- ◆ *Do not permit joint sealant to be used where it would need*

replacement or renewal to maintain leak-proof construction for the life of the metal.

- ◆ For steep slope sheet metal roofing and for gutter linings use one of the following:
 - Type 304 stainless steel
 - Copper
- ◆ For applied gutters and downspouts, use one of the following:
 - Type 304 stainless steel
 - Copper
 - Kynar or Hylar
 - Coated aluminum

07-10

07 8100 – Spray-Applied Fireproofing for Concealed Interior Locations

Cementitious type with aggregate; mineral fiber type not permitted.

- ◆ Density: 14 lb/cu ft, minimum.
- ◆ Impact Strength: Passing ASTM E 760.
- ◆ Bond Strength: 300 psf, minimum, tested in accordance with ASTM E 736.

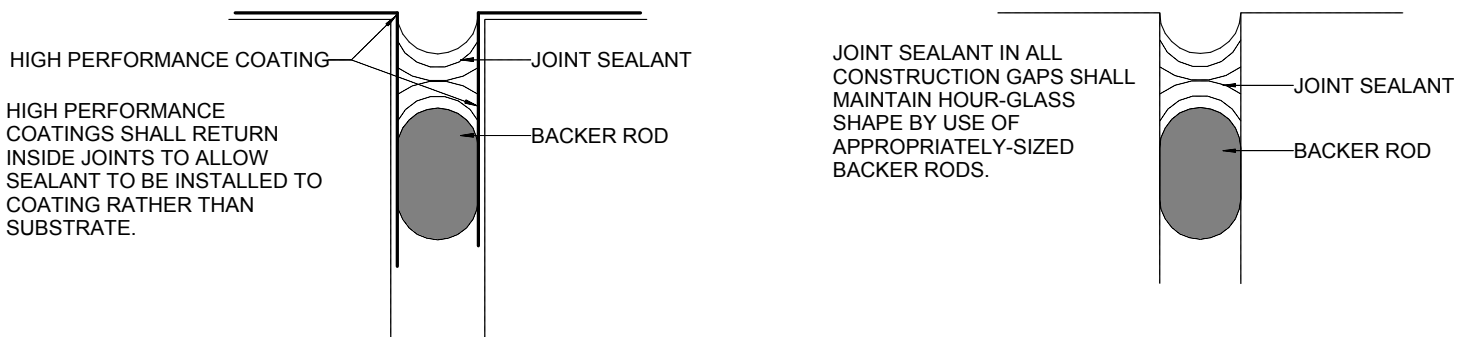

fig. 07a: TYPICAL JOINT SEALER DETAILS

Quality Assurance: Require that the contractor perform field adhesion tests– witnessed by the joint sealant manufacturer - for each sealant/ substrate combination and report results.

THERMAL AND MOISTURE PROTECTION**07 9200 – Joint Sealers**

Joint Sealers in Exterior Skin. Employ products of a single manufacturer for all exterior sealants. Obtain a 20-year manufacturer's warranty. Use the following:

- ◆ *Silicone sealant.*
- ◆ *Acceptable manufacturers:*
 - *Dow Corning*
 - *GE Construction Sealants*
- ◆ *Do not use:*
 - *Polyurethane sealant.*
 - *Acrylic sealant.*
- ◆ *Siliconized acrylic sealant.*

Where wide joints are necessary, use the following:

- ◆ *Self-expanding foam seal topped with silicone sealant*
- ◆ *Acceptable manufacturers:*
- ◆ *Emseal*

Quality Assurance: Require that the contractor perform field adhesion tests—witnessed by the joint sealant manufacturer - for each sealant/substrate combination and report results.

Openings

DIVISION 08

Contents

- 08-02 08 1400 – Interior Doors
- 08-03 08 4000 – Glazing Other Than Windows
- 08-03 08 5000 – Exterior Windows
- 08-04 08 6000 – Roof Glazing
- 08-04 08 7100 – Door Hardware And Keying
- 08-04 08 9000 – Other Exterior Openings

08-01

List of Figures

- 08-03 *fig. 08b: Standard Windows*

OPENINGS

08 1400 – Interior Doors

Interior doors are almost always wood. Exceptions to this rule would apply only to service doors and must be with permission of the Office of the University Architect. General University preferences:

Stained style and rail doors whether wood panel infilled or glazed are to be white Oak unless existing conditions require a match of another species.

Exterior painted style and rail doors to be white Oak, Mahogany, or Fir depending on location.

Interior painted style and rail doors to be Poplar or Maple with dense and smooth grain.

Interior stained flush type doors to be white Oak veneer unless existing conditions require a match from another species.

Painted flush type doors are to be Birch.

All new style and rail type doors to maintain 6 inch minimum styles to accommodate the 8200 series lock sets. All flush doors to be constructed with extra wide internal styles and top rail for hinge and closer attachments.

It should be discussed with the F&CS group whether fully welded or knock-down frames are appropriate. In general for institutional use and 100-year buildings welded frames are preferred.

The following are specifics for different room types:

RESIDENCE HALL STUDENT ROOMS

- ◆ *Flush wood type door 1 ¾" thick construction*
- ◆ *Solid wood styles and rails*
- ◆ *Birch/Oak, custom stained*

RESIDENCE HALL SUITE DOORS TO STUDENT ROOMS

- ◆ *Solid Style and Rail type door of 1 ¾" thick construction*
- ◆ *Solid bottom and nine-light, true divided light window*
- ◆ *Birch/Oak, custom stained*
- ◆ *Fir if painted*

CLASSROOMS

- ◆ *Design and configuration depends on the building*
- ◆ *Most instances in most buildings have glass in upper half of the door with a solid bottom*
- ◆ *Styles and rails are always solid construction*
- ◆ *Oak/Birch, custom stained*

OPENINGS

OFFICES

- ◆ *Design and configuration depends on the building*
- ◆ *Most instances in most buildings have glass in the upper half of the door with a solid bottom*
- ◆ *Styles and rails are always solid construction*

08 4000 – Glazing Other Than Windows

Expanses of storefront, curtain wall, and similar glazing are not permitted without variance from the Office of the University Architect.

If and where aluminum-framed expanses of glazing are permitted by variance, the use of storefront shall be limited to openings in first or second stories, and well-protected from rain by suitable recess or overhang; otherwise window wall or curtain wall will be required. Curtain wall assemblies shall be designed in consultation with a North Carolina licensed structural engineer.

Glazing in the radio room/communications at Public Safety shall be blast and bullet proof unless otherwise indicated by Facilities and Campus Services.

08 5000 – Exterior Windows

Exterior windows shall be operable, double-hung sash of commercial quality and constructed of Kynar 500 or Hylar 500 coated aluminum; wood, wood-clad, vinyl, or other compositions will not be permitted.

Particular attention shall be paid during design to proportion including overall window size and profile of frame, sash, and muntins. Eight over eight shall be standard for typical windows with twelve over twelve employed for monumental windows. **Refer to figure 08a (below and right) for standard window configurations.**

fig. 08b: STANDARD WINDOWS

Particular attention shall be paid during design to proportion including overall window size and profile of frame, sash, and muntins. Eight over eight (right) shall be standard for typical windows with twelve over twelve (far right) employed for monumental windows.



OPENINGS

Provide insect screens with aluminum or stainless steel mesh for Freshman Residence Hall windows. Furnish operable sash with six-inch stops.

Glazing shall be low-e type sealed insulating units, clear, with a CBA rating and 10-year warranty.

Provide units manufactured by one of the following:

- ◆ *EFCO*
- ◆ *Traco*
- ◆ *Custom Window Co.*
- ◆ *Graham Architectural Products*
- ◆ *Peerless Architectural Windows and Doors*

08 6000 – Roof Glazing

Aluminum-Framed Skylights: No uncontrolled water penetration at static pressure of 20% of positive design pressure but not less than 12 psf when tested in accordance with ASTM E 331.

Glazing: Sealed insulating low-e glass units with inboard laminated light.

DO NOT USE

- ◆ *Acrylic plastic glazing sheet.*
- ◆ *Fiberglass-reinforced plastic glazing sheet.*

08 7100 – Door Hardware And Keying

Wake Forest University provides hard keying for all projects. The Locksmith Shop utilizes two SFIC core systems: a Level 5 Kaba High Security keying system and a Sargent Keso keying system. Wake Forest University's keying systems are custom for which only the University may approve and order cylinders, blanks and housings. Wake Forest University will also provide construction cores which the contractor will install for each project. The University is responsible for installing permanent cores in cooperation with the contractor and his/her schedule. Wake Forest prefers not to use vertical rod exit devices or magnetic locks. High end finishes may require accommodations as directed by F&CS.

08 9000 – Other Exterior Openings

Louvers for air intake and exhaust shall be concealed from view or otherwise treated so as not to detract from the prevailing campus aesthetic. Construct louvers of Kynar 500 or Hylar 500 coated aluminum. Minimum performance: No water penetration at Test Air Velocity for exhaust openings and at normal operational velocity for intake openings; AMCA 511 certified water penetration ratings.

Finishes

DIVISION 09

Contents

- 09-02 09 0610 – Partition Schedule
- 09-02 09 2116 – Gypsum Board Assemblies
- 09-04 09 2600 – Gypsum Veneer Plaster
- 09-05 09 3000 – Tile (Ceramic, Porcelain, Stone and Glass)
- 09-07 09 5100 – Suspended Acoustical Ceilings
- 09-07 09 6010 – Flooring Transitions
- 09-08 09 6500 – Resilient Flooring (VCT, Linoleum, Rubber, etc.)
- 09-10 09 6623 – Epoxy Terrazzo Flooring System
- 09-13 09 6723 – Resinous Flooring
- 09-15 09 6800 – Carpet
- 09-16 09 9100 – Paints and Coatings
- 09-22 09 9600 – High Performance Coatings

09-01

List of Figures

- 09-25 *fig. 09b: High Performance Coating Joint Detail*

FINISHES

09 0610 – Partition Schedule

Either in the project drawings or in the project specifications there shall be a partition schedule that clearly indicates every wall assembly, including any information unique to that system and at the least reference to wall composition, wall height/how it is braced, wall rating and corresponding UL designation, smoke, dust and noise or sound transmission information.

09 2116 – Gypsum Board Assemblies

Typical assemblies to which this section pertains:

- ◆ *All assemblies in this division are interior. For exterior gypsum sheathing refer to Division 6.*
- ◆ *This section includes non-load bearing framing for gypsum wall board assemblies. For load bearing, light gauge/ cold formed framing assemblies, refer to Division 5.*
- ◆ *This section includes interior acoustic insulation only. For all other insulation specifics, refer to Division 7.*

09-02

DRAWING INFORMATION

- ◆ *Indicate rated partitions by using graphic line types and specifying partition types which meet UL designations.*
- ◆ *Show gypsum wall board control joints in plan and reflected ceiling plans and when elevated in elevation drawings.*
- ◆ *When special trims for reveals, edge treatments, vents and picture hangers are used, they should be elevated and detailed in the contract drawings.*

STORAGE, HANDLING AND PROJECT CONDITIONS

- ◆ *All material shall be stored in a dry location, fully protected from weather and direct exposure to large temperature swings and sunlight.*
- ◆ *Do not allow materials of this section to be delivered to or stored in a building until fully enclosed and temperature and humidity are being controlled.*
- ◆ *Installation temperature shall meet manufacturers requirements or between 50 and 80 degrees F for at least 48 hours prior to installation and continuously thereafter.*

FINISHES

MATERIALS

- ◆ Framing system components shall conform to ASTM C 645 and ASTM C 754 for the height of walls and spans of ceilings and soffits.
- ◆ Minimum framing thickness in all locations is 0.0188 inch design and 0.0179 for base metal thickness.
- ◆ Minimum framing thickness where tile backer board is used for any reason shall be 0.0312 inch design thickness and 0.0296 inch minimum base metal thickness.
- ◆ Minimum framing thicknesses noted above refer to the steel sheet itself used in the making of framing. So called “EQ” or “Equivalent” gage as manufacturer’s claim knurled, dimpled or deformed studs to be is not acceptable.
- ◆ Gypsum wall board to conform to ASTM C 1396, type X, labeled by UL, minimum thickness is 5/8 inch with tapered edges.
- ◆ Abuse, Abrasion Resistant or Impact Resistant drywall to be used only at the specific request of Wake Forest University.
- ◆ Water Resistant Backing Board to conform to ASTM C 1396 and ASTM C 630, type X, labeled if used in UL assembly, minimum thickness is 5/8 inch with tapered edges.
- ◆ Glass Mat Faced Gypsum Backing Board to conform to ASTM C 1178 with core complying with ASTM C 630, type X, labeled if used in UL assembly, minimum thickness is 5/8 inch with tapered edges.
- ◆ Shaftwall shall conform to ASTM C 1396, 1 inch thick with square cut edges and ends.
- ◆ Joint compound to be made in the USA.
- ◆ Sound attenuation blankets to be installed in all interior walls separating occupied spaces.

FINISHING

Drywall finishes are characterized by a level system. The following are descriptions of the five levels:

- ◆ Level 1 – Typically located above finished ceiling, concealed from view from approximately 8 inches above the finished ceiling to top of partition.
- ◆ Level 2 – Under tile finishes, in utility areas and areas behind cabinetry.
- ◆ Level 3 – Is typically reserved for walls scheduled to receive textured wall finish.

FINISHES

- ◆ *Level 4 – Unless otherwise specified all drywall should be finished to level 4 – typical for surfaces to receive flat or eggshell paint finishes.*
- ◆ *Level 5 – The highest level of finish, typical for walls scheduled to receive semi-gloss or gloss paint, environmental scrubbable coatings, high performance coatings specified in 09 9600 High Performance Coatings and under Visual Display Wall Coverings typically specified in 10 1146 Visual Display Wall Coverings.*

ASTM C840 and the Recommended Levels of Gypsum Board Finish by the Gypsum Association set the standards by which the above noted levels are measured.

09 2600 – Gypsum Veneer Plaster

09-04

TYPICAL ASSEMBLIES TO WHICH THIS SECTION PERTAINS:

Primarily used for additional protection on gypsum wall board walls or to blend with existing plaster and veneer plaster installation, gypsum veneer plaster is 1/16 inch thick per coat and is typically applied to gypsum veneer base.

QUALITY ASSURANCE

- ◆ *To a lesser extent than conventional plaster but nevertheless, veneer plaster is an art form and should be performed by experienced and skilled craftsman.*
- ◆ *A mock up, which may remain in-place should be performed prior to extensive veneer plaster coverage being installed on a project.*
- ◆ *The temperature and humidity requirements for veneer plaster are the same as for gypsum wall board storage and installation.*
- ◆ *Installation of veneer plaster – Install in accordance with ASTM C 843, including technical appendix X2 and with manufacturer's instructions.*

MATERIALS

- ◆ *Gypsum Veneer Plaster materials shall conform to ASTM C 587.*
- ◆ *Gypsum Veneer Base (drywall) shall conform to ASTM C 588, fire rated Type X, minimum thickness 5/8 inch.*

FINISHES

09 3000 – Tile (Ceramic, Porcelain, Stone and Glass)

TYPICAL ASSEMBLIES TO WHICH THIS SECTION PERTAINS:

Horizontal and vertical tile, mosaic tile, tile setting materials and installation on various substrates.

QUALITY ASSURANCE

- ◆ *To establish an acceptable standard of quality for comparison during installation and to verify materials submitted, a 4 foot x 4 foot mock-up for each tile type with setting materials and grout should be required.*
- ◆ *In construction, for liquid waterproofing, membrane test cuts to measure thickness shall be performed.*
- ◆ *After membrane test cuts have been made, communicated to the architect and found by all to be in conformance with the project specifications, water proofing is to be reinstalled at test cut locations allowed to cure and flood tests are to be performed. Flood test shall be performed at a minimum at the drain with the drain piping clogged with plumber's balloon or other apparatus below the drain. Fill waterproofed area with water to a depth of 2 inches measured at the shallowest point and allow to stand for at least 24 hours. Installation shall be leak-free.*
- ◆ *For tile material, handling, installation and maintenance, the TCNA "Handbook for Ceramic Tile Installation" by the Tile Council of North America, Inc. will be the governing authority.*

MATERIALS

- ◆ *Ceramic Tile Standard: ANSI A137.1 – "Standard Grade" unless noted otherwise.*
- ◆ *For Tile Products, include complete product brand name and number, color, size etc. for each tile type.*
- ◆ *Setting, grouting and waterproofing materials shall be by one of the following manufacturers unless otherwise permitted by the Office of the University Architect: Bostik/Hydroment, Custom Building Products, Laticrete International, Inc., and Mapei Corporation.*
- ◆ *Thick set Portland cement mortar installation materials: ANSI A108.1 A, B or C as recommended by TCNA.*
 - *Cleavage Membrane: Asphalt saturated felt, ASTM D 226, Type*

1, No. 15.

- *Setting bed reinforcing: Galvanized welded wire fabric, 2 inches by 2 inches, ASTM A 185; with W0.3 x W0.3, 0.0625 inch diameter, wire, ASTM A 82*
- ◆ *Thin set Latex Portland Cement Mortar: Two-component, dry mortar mix and liquid latex additive, field mixed; complying with ANSI A118.4.*
- ◆ *Organic Adhesive: ANSI A136.1*
- ◆ *Liquid-Applied, Elastomeric, Crack and Sound Isolation, and Positive Waterproofing Membrane (Fabric detail reinforcement shall be required by this specification at coves, corners, changes in plane, cracks, drains and joints):*
 - *Hyroment Ultra-Set Advanced; Bostik Inc.*
 - *RedGuard Crack Prevention and Waterproofing Membrane; Custom Building Products*
 - *Maplastic AquaDefense; Mapei Corporation*
 - *Laticrete Hydro Ban or Hydro Barrier; Laticrete International*
- ◆ *Grouting materials: Latex-Portland Cement Grout: Two-component, dry grout mix and liquid latex additive (no water), field-mixed; complying with ANSI A118.6.*
 - *All components premeasured and prepackaged.*
 - *Liquid latex additive: Acrylic resin water emulsion.*
 - *Mix in accordance with manufacturer's recommendations.*
- ◆ *Grouting materials: Chemical-Resistant, Water-Cleanable Ceramic Tile Setting and Grouting Epoxy: ANSI A118.3.*
- ◆ *Patching and leveling compound: Portland cement base, acrylic polymer compound, manufactured specifically for resurfacing and leveling concrete floors. Capable of being applied in layers up to two inches thick, being brought to a feather edge and being troweled to a smooth finish.*
 - *Compressive strength – 3,500 psi*
 - *Tensile strength – 1,000 psi*
 - *Flexural strength – 1,000 psi*

ACCESSORIES

Marble thresholds shall conform to ASTM C 503. At door openings, install a single full-width piece; notch threshold to door jamb profile. Depending on location and usage Corian thresholds may be considered.

FINISHES

09 5100 – Suspended Acoustical Ceilings

TYPICAL ASSEMBLIES TO WHICH THIS SECTION PERTAINS:

Suspended metal ceiling grid system, acoustical units and accessories.

QUALITY ASSURANCE

- ◆ *Work shall be sequenced to ensure acoustical ceilings not installed before the building is enclosed and temperature and humidity control is in place, working and in use, dust generating activities have terminated and overhead work is completed, tested and approved.*
- ◆ *It is essential to require attic stock to be provided for all ceiling tile types specified on a project.*

MATERIALS

- ◆ *Acoustic tiles vary significantly in design and cost. All tiles used on these projects shall be Class A per ASTM E 1264.*
- ◆ *Acoustic tile noise reduction, light reflectance, size and shape shall be determined according to the needs of the project program.*
- ◆ *Grid material shall be 15/16 inch Heavy Duty. 9/16 inch grid is not allowable at WFU.*
- ◆ *Support channels and hangers shall be galvanized steel size and of a type to suit the application, seismic requirements and ceiling system flatness requirements.*
- ◆ *Perimeter moldings, at exposed grid, provide L-shaped molding for mounting at same elevation as face of grid.*
- ◆ *Provide touch-up paint to match acoustic tiles and suspension grid used on the project.*

09-07

09 6010 – Flooring Transitions

Transitions are important for accessibility of occupants and maintenance, longevity and appearance of flooring materials in all new and renovation work. In no instance will an abrupt abutment of materials be acceptable; a finish height variation of more than 1/16" between adjacent flooring surfaces will be considered abrupt. Typically, a transition adaptor or receptor is to be employed, especially when hard and soft surfaces are adjacent. As prescribed by ANSI and ADA, thresholds and transition strips are permitted as much as a ¼ inch difference between one floor finish and the transition material, but in all cases, consideration

FINISHES

must still be given to color and contrast of materials to ensure they are seen by all building occupants with or without disabilities. Use of the space is another critical consideration, as some transition materials are unsuitable for the frequent use of rolling carts or other wheeled equipment. Waterproofing and containment may also be areas of concern. Finally, appropriateness of material selection must be taken into account. When in doubt, confer with Facilities and Campus Services.

09 6500 – Resilient Flooring (VCT, Linoleum, Rubber, etc.)

TYPICAL ASSEMBLIES TO WHICH THIS SECTION PERTAINS:

Resilient sheet flooring, resilient tile flooring, cove base, stair case treads and risers and flooring transition accessories. In general VCT is preferred over sheet type flooring materials.

09-08

QUALITY ASSURANCE

- ◆ *Discuss with Facilities and Construction Services the maintenance preferences before specifying these products.*
- ◆ *Arrange with F&CS to test existing flooring and mastic for asbestos containing materials (ACMs). Federal law requires that this be done before removal begins. If ACMs are detected then additional requirements are necessary which are outside the scope of this document. Refer to Hazardous Materials in Division 1.*
- ◆ *If product is to be installed on new concrete flooring, the slab shall be tested for vapor transmission/vapor content per flooring manufacturer instructions.*
- ◆ *Product shall be stored between 55 and 90 degrees F. Product shall not be installed until temperature in the space to receive the flooring has been maintained between 65 and 85 degrees for at least 48 hour prior to installation and shall be maintained within this range for the duration of the project after installation.*

MATERIALS SHEET FLOORING

- ◆ *Vinyl Sheet Flooring: ASTM F 1913, vinyl sheet floor covering without backing, color and pattern throughout wear layer thickness.*
 - *Total Thickness and Wear Layer Thickness: 0.080 inch nominal.*
 - *Seams: Heat welded to match flooring color unless otherwise approved by the University Architect.*
- ◆ *Rubber Sheet Flooring: ASTM F 1860, rubber sheet flooring with*

FINISHES

backing; color and pattern through total flooring thickness.

- *Total Thickness: 0.118 inch minimum.*
- *Seams: Heat welded to match flooring color.*
- ◆ *Linoleum Sheet Flooring: ASTM F 2034, Type 1; homogeneous, with color extending throughout material thickness.*
 - *Backing: Organic*
 - *Total Thickness: 0.100 inch minimum.*
 - *Preferably used when seams are not required.*

MATERIALS TILE FLOORING

- ◆ *Vinyl Composition Tile (VCT) or Resilient Composition Tile (RCT): ASTM F 1066, Class 2; homogeneous, with color extending throughout thickness.*
 - *This material is almost always 12 inch x 12 inch and 0.125 inches thick.*
- ◆ *Rubber Tile: ASTM F 1344, Class 1; homogeneous rubber tile with color and pattern throughout thickness.*
 - *This material may be 18 inches x 18 inches, 24 inches x 24 inches and 19 11/16 inches x 19 11/16 inches depending on manufacturer.*

09-09

MATERIALS STAIR COVERING

- ◆ *Stair Treads: ASTM 2169, Type TS Rubber; full width and depth of stair tread in one piece, tapered thickness.*
 - *Nominal Thickness: 0.125 inch.*
- ◆ *Stair Risers: Full height and width of tread in one piece, matching treads in material and color.*
 - *Nominal Thickness: 0.080 inch.*

MATERIALS BASE

- ◆ *Resilient Base: ASTM F 1861, Type TP thermoplastic rubber. Specify height, thickness, finish, color, style, material length and manufacturer and product.*

MATERIALS ACCESSORIES

Refer also to section 09 6010 - Flooring Transitions.

- ◆ *Carpet to Carpet: ¼ inch material to ¼ inch material – T molding.*
- ◆ *Carpet to Sub-floor: ¼ inch material to sub-floor - Transition Strip.*

- ◆ *Carpet to Resilient Floor material: ¼ inch material to 1/8 inch material – Adaptor.*
- ◆ *Resilient to Sub-floor: 1/8 inch material to sub-floor – Reducer.*
- ◆ *Resilient to Resilient: 1/8 inch – T molding.*
- ◆ *Sealer and Wax/Finish Products: As recommended by flooring manufacturer.*
- ◆ *Discuss this with F&CS prior to specifying. Typically four wax coats are provided with initial installation after construction cleaning.*

09 6623 – Epoxy Terrazzo Flooring System

TYPICAL ASSEMBLIES TO WHICH THIS SECTION PERTAINS:

- ◆ *Epoxy terrazzo will be employed in one of three forms: a monolithic poured in place assembly, thin set and grouted precast tile assembly, and an adhered resilient assembly. It may be specified in a tile specification, a resilient flooring specification or in a dedicated Epoxy Terrazzo Flooring System specification.*
- ◆ *For simplicity purposes, each of these assemblies will be discussed here.*
- ◆ *This section will also address epoxy terrazzo base and installation accessories.*

QUALITY ASSURANCE

- ◆ *For slabs on grade, a proper vapor barrier must be installed whether construction is existing or new. It shall be a Class A vapor barrier complying with ASTM 1745. If installed new as part of this project, it shall be installed per ASTM E 1643 which includes requirements for taping seams, detailing at vents and penetrations, penetrations and other key details for a quality vapor barrier installation.*
- ◆ *The slab shall be tested for moisture vapor transmission. If existing, this shall be done during design. If the slab is new, it shall be done prior to installation of the terrazzo system. In all cases, it shall be done per the requirements set forth in ASTM F-2170.*
- ◆ *Membrane detailing for crack mitigation – All cracks shall be detailed with a flexible fabric epoxy membrane, which will separate the epoxy terrazzo system from the substrate at the crack in order to allow for minimal movement without damage to the terrazzo*

FINISHES

system. This is less an issue for resilient terrazzo, but should still be considered for cracks over 1/16 inch wide.

- ◆ Full Membrane Systems are expensive and should be reserved for installations where there is excessive cracking and movement in a slab or where there are intricate details in the terrazzo design. This system will allow for up to 130 percent elongation (in cracks and movement joints) and 1500 psi tensile strength.
- ◆ All work shall be performed in accordance with the National Terrazzo and Mosaic Association (NTMA) recommendations as posted at their web site at www.ntma.com.
- ◆ Use only qualified installers that provide proof of NTMA membership in good standing, and that provide proof of at least 5 successful, quality installations of similar scope and complexity.
- ◆ Mock-ups are not negotiable and must be specified and depicted on the contract drawings. The mock-up must demonstrate material, detailing, finish and appearance standards to be reviewed and approved or rejected by Facilities and Campus Services and the project designer. Mock-ups shall be done only after the balance of terrazzo related submittals have been reviewed and approved by the Architect.
- ◆ Do not install terrazzo when temperature is below 50 degrees F or above 90 degrees F.
- ◆ Maintain temperature within specified range 24 hours before, during, and 72 hours after installation of flooring.

09-11

MATERIALS EPOXY TERRAZZO (POURED AND GROUND IN-PLACE ASSEMBLY)

Epoxy Matrix: Two component resin and epoxy hardener with mineral filler and color pigment, non-volatile, thermo-setting.

Aggregate: Crushed marble, glass or other material as specified in accordance with NTMA Plate that is selected for the installation.

Accessories:

- ◆ Divider Strips: 1/8 inch thick zinc, brass or stainless steel (select one) exposed top strip, zinc coated steel concealed bottom strips.
- ◆ Control Joint Strips: 1/8 inch nominal width zinc, brass or stainless steel (select one) exposed top strips, zinc coated steel concealed bottom strips.
- ◆ Wall base cap, base divider strip and base separator strip to match flooring divider strips.

FINISHES

- ◆ *Flexible Epoxy Membrane (For Full Membrane Installation ONLY): 100 percent solids for full coverage with the following properties: Tensile Strength, ASTM D 2370, 20 deg C, 1,500 psi; Elongation, ASTM D 2370, 20 deg C, 130 percent.*
- ◆ *Primer, Slope and Fill Mortar, Epoxy Grout, Control Joint Filler, Cleaner and Sealer as recommended by manufacturer for the specific project conditions and desired finish.*

MATERIALS PRECAST TERRAZZO TILE (THIN SET AND GROUTED)

- ◆ *Tile materials are essentially the same as the epoxy matrix and aggregates for Epoxy Terrazzo as noted above.*
- ◆ *Tile Size: Varies by design and manufacture between 11 13/16 inch square – 23 13/16 inch square and 7/16 inch thick – 7/8 inch thick. Custom shapes for patterns may also be applicable.*
- ◆ *It is important that all tile intended to match be provided from the same production run.*
- ◆ *Tile edges to be chamfered*
- ◆ *Tile Surface finish to be ground and polished, free of holes and rough areas.*
- ◆ *Tile Surfaces to be consistent and uniform in appearance.*
- ◆ *Thin set mortar and grout as specified in section 09 3000 Tile.*
- ◆ *Crack isolation membranes as specified in 09 3000 Tile.*

MATERIALS RESILIENT TERRAZZO TILE (ADHERED SIMILAR TO VCT)

- ◆ *Generally resilient terrazzo is manufactured to resemble a classic terrazzo appearance or a natural quarry tile appearance.*
- ◆ *Tile is composed of crushed marble, glass and/or granite chips embedded in a thermo-set resin matrix that is flexible. Typically tile is UV cured. To be manufactured per NTMA requirements.*
- ◆ *Standard size is 12 inch x 12 inch square and 3/16 inch thick. Custom sizes and patterns are available.*
- ◆ *It is important that all tile intended to match be provided from the same production run.*
- ◆ *Adhesive as recommended by manufacturer for specific project conditions.*
- ◆ *Sealer as recommended by manufacturer.*

FINISHES

INSTALLATION REQUIREMENTS

- ◆ *Installation requirements are detailed and extensive for each type of system and for sub-types of poured in-place epoxy terrazzo in particular.*
- ◆ *Epoxy Terrazzo Installation: The NTMA provides detail preparation, mixing, installation and finishing instructions for this assembly including detailed instructions for crack detailing and full membrane application. Installation requirements are to be thoroughly researched and specified specific to each project for each assembly type and application.*
- ◆ *Precast Terrazzo Tile Installation: Shall be per the Tile Council of North America (TCNA) and manufacturer guidelines and instructions.*
- ◆ *Resilient Terrazzo Tile Installation: Per manufacturer instructions. Moisture test shall be performed and the substrate found to be compliant with manufacturer instructions prior to flooring installation.*

09-13

09 6723 – Resinous Flooring

Typical assemblies to which this section pertains: resinous flooring is often employed in high traffic areas where soiling, compression resistance, waterproofing, containment and the need to disinfect or sanitize the space is frequent. These areas typically include: loading/ receiving, food prep and kitchens, teaching laboratories, research laboratories, greenhouses, shower rooms and showers, utility rooms and sometimes mechanical rooms.

QUALITY ASSURANCE

- ◆ *Manufacturer's Qualifications: One of the following manufacturers shall be used on all Wake Forest University projects:*
 - *Stonhard; www.stonhard.com*
 - *Dudick Inc.; www.dudick.com*
 - *Tnemec; www.tnemec.com*
 - *Manufacturer's technical representative shall be available on site to advise applicator on proper surface preparation and application techniques.*
- ◆ *Applicator's Qualifications: All work of this section shall be performed by an installer who shall be either employees of the resinous flooring manufacturer, or contract workers of the resinous flooring manufacturer who are specifically trained by the resinous flooring*

manufacturer. Applicator must have 5 years documented experience installing the manufacturer's product.

- ◆ *Mock-Up: Install Resinous Flooring System mock up in one room only, selected by the Architect, for verification of color and texture. Mock-up shall be adjusted as required by the Architect.*
 - *If no rooms should be of suitable size for mock-up, provide 4-foot-square sample panels, constructed of concrete not less than 3-1/2 inches thick, in lieu of mock-up in actual room.*
- ◆ *Concrete substrate shall be properly cured for at least 30 days.*
- ◆ *Coatings shall only be applied under the following conditions:*
 - *Air and surface temperatures are between 70 and 85 degrees F.*
 - *Relative humidity is less than 75 percent.*
 - *Surface temperature is at least 5 degrees F above dew point.*
 - *Permanent lighting system shall be functional, or provide temporary lighting providing with at least the level of lighting given by permanent lighting system.*

MATERIALS RESINOUS FLOORING

- ◆ *There are numerous resinous flooring systems for many different applications. Each situation merits thoughtful consideration of the appropriate system.*
- ◆ *Regardless of the application and the manufacture and system chosen, the following series of layers are the minimum components in a total system and each layer must be specified as to the specific manufacturer's product, layer thickness and total minimum thickness of the whole system etc.*
 - *Epoxy primer*
 - *Osmotic Grout Moisture Control*
 - *Body coat(s)*
 - *Top coat(s)*
- ◆ *Where waterproofing to protect occupied spaces below the floor being finished in resinous flooring is required, a waterproofing membrane layer will also be part of the total composition and must be carefully coordinated with the system component layers.*

MATERIALS ACCESSORIES

- ◆ *Divider Strips: zinc metal minimum 16 gauge unless otherwise detailed in the contract documents. Some protective/sacrificial*

FINISHES

edges in high traffic areas are 1/8 inch material.

- ◆ *Cove Strip: Provide manufacturer's standard zinc metal cove strip to which resinous floor is terminated*
- ◆ *Expansion Strip: Back-to-back metal "L" strips bonded to ¼ inch wide black neoprene filler.*

PREPARATION AND INSTALLATION

- ◆ *In all instances, unless expressly rejected by the manufacturer, the concrete substrate or previously prepared resinous substrate shall be bead blast cleaned to remove bond inhibiting materials such as curing compounds, laitance, dirt, grease, adhesives and previous coatings in their entirety.*
- ◆ *After blast cleaning, test the vapor transmission of slabs on grade per requirements set forth in ASTM F-2170 in accordance with the following schedule:*
 - *2 tests for areas up to 500 sf.*
 - *3 tests for areas up to 1000 sf.*
 - *4 tests for areas up to 5000 sf.*
 - *1 additional test for each additional 5000 sf.*
- ◆ *Apply each component of the resinous flooring system in compliance with manufacturer's direction to produce a uniform, monolithic wearing surface of thickness indicated.*

09-15

09 6800 – Carpet

TYPICAL ASSEMBLIES TO WHICH THIS SECTION PERTAINS:

The University preference is to use carpet tile for all spaces where matching an existing carpet is not an issue. Broad loom carpet will only be considered on a case-by-case basis and must be approved in writing by the F&CS project manager.

Stretched-in broad loom with cushion underlay, direct-glued broad loom and adhered carpet tile.

QUALITY ASSURANCE

Maintain minimum 70 degrees F ambient temperature 24 hours prior to, during and 24 hours after installation.

FINISHES

MATERIALS

- ◆ *Carpet and Carpet Tile selection is unique to project and manufacturer. In all cases, backings should be made of recycled content and adhesives must be low-VOC.*
- ◆ *Carpet and adhesives shall meet building code requirements for flame spread and smoke development for the spaces and occupancies in which they are used.*
- ◆ *Carpet padding to be specified to meet current ADA requirements and ANSI guidelines.*

09 9100 – Paints and Coatings

Typical assemblies to which this section pertains: paints and coatings on new and previously painted surfaces.

Exterior materials include:

- ◆ *Concrete Walls*
- ◆ *Stucco*
- ◆ *Concrete Masonry Units*
- ◆ *Ferrous Metals*
- ◆ *Galvanized Metals*
- ◆ *Gypsum Board Soffits*
- ◆ *Wood*
- ◆ *Hardboard/ Cement Board Siding and Trim*
- ◆ *Fiberglass*

Interior materials include:

- ◆ *Concrete Walls*
- ◆ *Plaster*
- ◆ *Concrete Masonry Units*
- ◆ *Ferrous Metals*
- ◆ *Galvanized Metals*
- ◆ *Gypsum Board*
- ◆ *Wood Doors, Windows and Trim*
- ◆ *Cement Board or Panels*
- ◆ *Telephone and Electrical Panel Backer Boards*

For high performance coatings and floor coatings for interior and exterior applications, refer to section 09 9600 High Performance Coatings.

FINISHES

QUALITY ASSURANCE

- ◆ *ASTM D 4258 – Standard Practice for Surface Cleaning Concrete for Coating; most current version.*
- ◆ *Steel Structures Painting Manual, Vol. 2; Systems and Specifications; Steel Structures Painting Council SSPC; most current version.*
 - *SSPC SP 1 – Solvent Cleaning; most current version.*
 - *SSPC-SP 2 - Hand Tool Cleaning*
 - *SSPC-SP 3 - Power Tool Cleaning*
 - *SSPC-SP 5 - White Metal Blast Cleaning*
 - *SSPC-SP 6 - Commercial Blast Cleaning*
 - *SSPC-SP 7 - Brush-Off Blast Cleaning*
 - *SSPC-SP 11 - Power Tool Cleaning to Bare Metal*
- ◆ *Indoor Air Quality – low VOC materials shall be used for interior application regardless of whether or not LEED, Green Globes or some other environmental/energy rating system is used on the project.*
- ◆ *Mock-ups may be relevant and helpful depending on the project and application.*
- ◆ *Application Temperatures for Waterborne Paints: Minimum 45 degrees F for interiors; minimum 50 degrees F for exterior; maximum 90 degrees F (32 degrees C), unless required otherwise by manufacturer's instructions. Maintain interior temperatures until paint is completely dry and cured.*
- ◆ *Application Temperatures for Solvent Thinned Paints: Minimum 50 degrees F (10 degrees C) for interiors and exterior; maximum 95 degrees F (35 degrees C), unless required otherwise by manufacturer's instructions. Maintain interior temperatures until paint is completely dry and cured.*

09-17

SURFACE PREPARATION

Surface preparation is as important as the quality and application of paint. The following are guidelines for preparation of various surfaces to receive paints and coatings.

Concrete Surfaces to be Painted:

- ◆ *Remove dirt, loose mortar, scale, salt or alkali powder, glaze, efflorescence, laitance, and other foreign matter.*
- ◆ *Remove oil and grease with a solution of trisodium phosphate; rinse well and allow to dry.*

- ◆ *Remove stains caused by weathering of corroding metals with a solution of sodium metasilicate after thoroughly wetting with water. Allow to dry.*
- ◆ *Detergent wash surfaces to receive paint, in accordance with ASTM D 4258. Rinse with water and allow to dry.*
- ◆ *Allow surfaces to dry at least 30 days before applying paint materials.*
- ◆ *Fill concrete surface voids. Dried filler shall be uniform and free of pinholes. Do not apply filler over joint sealers.*

Concrete Unit Masonry Surfaces to be Painted:

- ◆ *Remove dirt, efflorescence, laitance, and other foreign matter.*
- ◆ *Remove oil and grease with a solution of trisodium phosphate; rinse well and allow to dry.*
- ◆ *Remove stains caused by weathering of corroding metals with a solution of sodium metasilicate after thoroughly wetting with water. Allow to dry.*
- ◆ *Surface clean concrete masonry to receive paint, in accordance with ASTM D 4261. Rinse with water and allow to dry.*
- ◆ *Allow surfaces to dry at least 30 days before applying paint materials.*

Stucco and Plaster Surfaces to be Painted:

- ◆ *Fill hairline cracks, small holes, and imperfections with latex patching plaster. Make smooth and flush with adjacent surfaces.*
- ◆ *Wash and neutralize high alkali surfaces.*
- ◆ *Allow to age minimum 30 days before painting.*
- ◆ *Clean of all loose matter that may affect paint application.*

Uncoated Ferrous Metal Surfaces to be Painted:

- ◆ *Remove grease, mill scale, weld splatter, dirt, and rust. Where heavy coatings of scale are evident, remove by hand wire brushing in accordance with SSPC SP-2, or sandblasting in accordance with SSPC SP-7; clean by washing with solvent or detergent in accordance with SSPC SP-1. Apply a treatment of phosphoric acid solution, ensuring weld joints, bolts, and nuts are similarly cleaned. Prime paint entire surface; spot prime after repairs.*

FINISHES

Shop-Primed Ferrous Metal Surfaces to be Finish Painted:

- ◆ *Sand and scrape to remove loose primer and rust. Feather edges to make touch-up patches inconspicuous.*
- ◆ *In flat, exposed surfaces to receive semi-gloss or gloss finish, fill dents, holes and similar voids and depressions in flat exposed surfaces with metal filler compound. Finish flush with adjacent surfaces.*
- ◆ *Clean surfaces with solvent in accordance with SSPC SP-1.*
- ◆ *Prime bare steel surfaces immediately upon detection.*

Galvanized Surfaces to be Painted:

- ◆ *Remove surface contamination and oils and wash with solvent in accordance with SSPC SP-1 or detergent. Wipe with metal cleaner, rinse, and wipe dry.*

Gypsum Board Surfaces to be Painted:

- ◆ *Fill minor defects with filler compound. Spot prime defects after repair.*
- ◆ *Remove loose dust and dirt by brushing with a soft brush, rubbing with a cloth, or vacuum cleaning. A damp cloth may be used when water based paint materials are to be applied. Allow to dry.*

Wood:

- ◆ *Wipe off dust and grit prior to priming.*
- ◆ *Scrape and clean small, dry seasoned knots, then apply a thin coat of commercial knot sealer, before application of the priming coat.*
- ◆ *Scrape off pitch on large, open, unseasoned knots and all other beads or streaks of pitch and sap. If the pitch is still soft, remove with mineral spirits or turpentine, and thinly coat the resinous area with knot sealer.*
- ◆ *Back prime concealed surfaces before installation.*
- ◆ *Sand between coats.*
- ◆ *Set finishing nails, fill holes, and prime surface imperfections. After priming, fill holes and imperfections in finish surfaces with putty or plastic wood filler, colored to match the finish coat if natural finish is required, allowed to dry, and sand smooth.*

Fiberglass:

- ◆ *Clean surfaces with warm soapy water.*
- ◆ *Sand fiberglass surfaces prior to priming and painting. Using 120 grit sandpaper.*
- ◆ *Thoroughly scuff and sand surface on polyurethane caps and bases/plinths.*
- ◆ *Wipe surfaces clean.*

Previously Painted Surfaces:

- ◆ *Thoroughly remove all grease, dirt, dust or other foreign matter.*
- ◆ *Remove coatings that are blistering, cracking, flaking, peeling, or otherwise deteriorating.*
- ◆ *Roughen slick surfaces.*
- ◆ *Repair damaged areas such as, but not limited to, nail holes, cracks, chips, and spalls with suitable material to match adjacent undamaged areas.*
- ◆ *Feather edge edges of chipped paint, and sand smooth.*
- ◆ *Clean metal surfaces in accordance with SSPC requirements using solvent, mechanical, or chemical cleaning methods to provide surfaces suitable for painting. Preparation of ferrous surfaces if not specified shall as recommended by coating manufacturer, but in no case less than SSPC SP-3.*
- ◆ *Chalk shall be removed so that when tested in accordance with ASTM D 4214, the chalk resistance rating is no less than 8.*

PAINT AND COATING APPLICATION

Unless otherwise specified or recommended by the paint manufacturer, paint may be applied by brush, roller, or spray. Rollers for applying paints and enamels shall be of a type designed for the coating to be applied and the surface to be coated.

- ◆ *Brushes: Use brushes best suited for type of material applied. Use brush of appropriate size for surface or item being painted.*
- ◆ *Rollers: Use rollers of carpet, velvet-back, or high-pile sheep's wool as recommended by manufacturer for material and texture required.*
- ◆ *Spray Equipment: Use airless spray equipment with orifice size as recommended by manufacturer for material and texture required.*

Thinning:

- ◆ *When thinning is required to suit surface, temperature, weather*

FINISHES

conditions, or application methods, paints may be thinned in accordance with the manufacturer's directions.

- ◆ *The use of thinner shall not relieve the Contractor from obtaining complete hiding, full film thickness, or required gloss. Thinning shall not cause the paint to exceed limits on volatile organic compounds.*
- ◆ *Do not mix paint materials of different manufacturers.*
- ◆ *Where adjacent sealant is to be painted, do not apply finish coats until sealant is applied.*
- ◆ *Do not apply finishes to surfaces that are not dry. Allow applied coats to dry before next coat is applied.*
- ◆ *Apply each coat to uniform appearance. Apply each coat of paint in a tint slightly darker than preceding coat unless otherwise approved. Difference in tint shall be visible at a distance of 3 feet (0.9 m) from the surface.*
- ◆ *Vacuum clean surfaces of loose particles. Use tack cloth to remove dust and particles just prior to applying next coat.*

09-21

Minimum Coating Thickness:

- ◆ *Apply paint materials no thinner than manufacturer's recommended spreading rate to achieve dry film thickness as recommended by manufacturer. Provide total dry film thickness of the entire system as recommended by manufacturer.*
- ◆ *Strip paint to ensure that all edges, corners, crevices, welds, and rivets receive a film thickness equal to that of adjacent painted surfaces.*
- ◆ *Apply each coat of paint so dry film shall be of uniform thickness and free from runs, drops, ridges, waves, pinholes or other voids, laps, brush marks, and variations in color, texture, and finish. Hiding shall be complete. If application thickness or color and opacity of the paint do not achieve complete hiding, apply additional coat(s) to achieve complete hiding without change in contract price.*
- ◆ *Apply two coats of primer or sealer to surfaces of wood doors, including top and bottom edges, which are cut.*

INTERIOR WALL AND CEILING JOINTS**Sealant-Type Expansion Joints in Gypsum Wallboard.**

- ◆ *Ensure that backer rod and joint sealant (specified in Division 7) are completed and cured prior to application of paint.*

FINISHES

Control and Expansion Joints in Concrete and CMU:

- ◆ *Apply coatings to the joint face (approximately 1/2 inch deep) and allow to cure before installing backer and joint sealant specified in Division 7.*

Fillet Joints between Hollow Metal Door Frames and Adjacent Walls (and similar locations):

- ◆ *Ensure that backer rod and joint sealant (specified in Division 7) are completed and cured prior to application of paint.*

09 9600 – High Performance Coatings

TYPICAL ASSEMBLIES TO WHICH THIS SECTION PERTAINS:

This section is dedicated to coatings which are intended to resist exceptional wearing, environmental, chemical and/or corrosive conditions and/or are required to be sanitized.

QUALITY ASSURANCE

- ◆ *The Society for Protective Coatings, Steel Structures Painting Manual, Vol. 2; Systems and Specifications; Steel Structures Painting Council SSPC; most current version.*
 - *SSPC SP 1 – Solvent Cleaning; most current version.*
 - *SSPC-SP 2 - Hand Tool Cleaning*
 - *SSPC-SP 3 - Power Tool Cleaning*
 - *SSPC-SP 5 - White Metal Blast Cleaning*
 - *SSPC-SP 6 - Commercial Blast Cleaning*
 - *SSPC-SP 7 - Brush-Off Blast Cleaning*
 - *SSPC-SP 11 - Power Tool Cleaning to Bare Metal*
- ◆ *Installer: A company skilled in the application of special coatings whose installations have performed in a satisfactory manner under comparable conditions.*
- ◆ *Indoor Air Quality: There are no substitutes that are low-VOC for some applications. There are instances where the VOC's are the ingredients that make the high performance coating perform as it is needed to. Where possible, though, low-VOC coatings should be employed as a first choice and otherwise ventilation provisions should be made for occupied buildings and areas of high traffic.*
- ◆ *Coordination with Work Specified in Other Sections: Where*

FINISHES

primers will be applied in the shop, apply the primers listed in the schedule at the end of this section.

- *Exception: Shop primed steel doors and frames shall receive fabricator's standard shop primer, followed by one full field coat of the primer specified in the schedule at the end of this section.*

Mock-Ups:

- ◆ *Mock-Ups are essential for High Performance Coatings to demonstrate the contractor's understanding of the preparation, mixing, application and clean up requirements.*
- ◆ *Apply coatings to mock-ups in the presence of the coating manufacturer's technical representative.*
- ◆ *Metals: Mock up one element of each coating system and color. Apply to mock up specified in the respective fabrication section, or if no mock up is specified therein, apply to an on-site mock-up as directed by the Architect.*
- ◆ *Floors: Mock up one room of each coating system.*
- ◆ *Rooms: Mock up one room of each coating system including walls, ceilings, doors, and other elements.*
- ◆ *Apply full coating systems, including required textures and colors, to mock-up. In interior spaces, provide completed lighting, or similar, for viewing of mock-up.*
- ◆ *Over CMU: apply filler, only, to one wall of space; apply filler and intermediate coat to one wall of the space; apply filler, intermediate coat, and finish coat to remaining walls.*
- ◆ *Remove and reapply coatings until texture, color, and gloss are approved by the Architect.*
- ◆ *Final approval of colors will be based on mock-up; obtain full job quantities of tinted materials only after obtaining final approval.*

Each layer of the assembly shall be specified with product name, dry film thickness and number of coats.

Apply coatings only under the following environmental conditions:

- ◆ *Air and surface temperatures are between 50 and 120 degrees F, or more restrictive when recommended by coatings manufacturer.*
- ◆ *Surface temperature is at least 5 degrees F above dew point, or more restrictive when recommended by coatings manufacturer.*
- ◆ *Relative humidity is less than 85 percent, or more restrictive when recommended by coatings manufacturer.*

FINISHES

Do not apply coatings during inclement weather except within enclosed, conditioned spaces.

Provide temporary lighting to achieve a well-lit surface with a level of not less than 80 footcandles measured mid-height.

Provide continuous ventilation and heating to prevent accumulation of hazardous fumes, and maintain surface and ambient temperatures as specified above for 24 hours before, during, and for 48 hours after application of finishes (or longer if required to obtain full cure as indicated by manufacturer's instructions).

At expansion and control joints, the coating shall extend into the joint such that the sealant binds from coating to coating. ***Refer to figure 09b, opposite page, top.***

MATERIALS

Provide all products of this section from a single manufacturer.

The brand-name products listed in the schedule at the end of this section and made by the following are the basis of the contract documents.

- ◆ *Tnemec Company, Inc.*
- ◆ *Carboline Company*
- ◆ *PPG Architectural Finishes*

High Performance Coatings are always gloss or semi-gloss but generally may be mixed to match any color except metallic. Metallics and pearlescents can be procured as specific mixes by specific manufacturers, but cannot be universally matched by any manufacturer.

Primer, Intermediate and Top Coats

- ◆ *Coating assemblies are specific to environment, substrate and use. Consult with the local manufacturer representative from each of the three manufacturers noted above.*
- ◆ *Except where coating materials cannot be tinted, tint each successive (primer, intermediate, top) coat of paint a sufficiently contrasting color to facilitate identification of complete coating coverage. The preceding coat may be in the same color family, but shall be noticeably different. Provide additional top coats without change in Contract Price if necessary to achieve complete hiding and uniform sheen.*

FINISHES

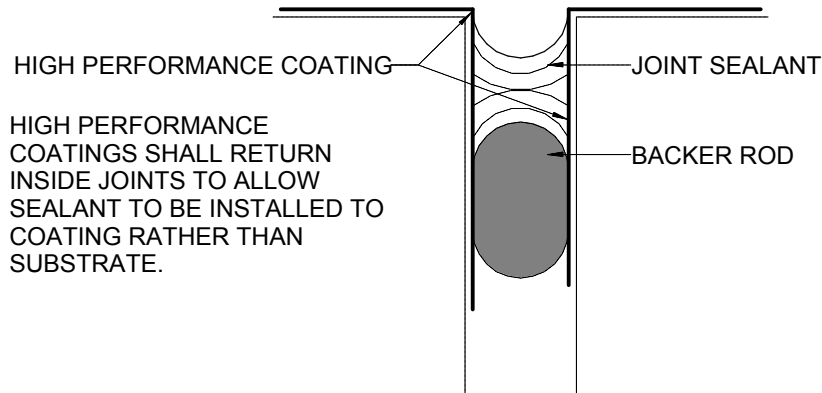

fig. 09b: HIGH PERFORMANCE COATING JOINT DETAIL

At expansion and control joints, the coating shall extend into the joint such that the sealant binds from coating to coating.

09-25

Fluoro-urethane Coatings on Metals:

- ◆ *System consists of: Epoxy primer, Epoxy or urethane intermediate coat, Fluoro-urethane polymer top coat. Specify each for each project condition.*

Urethane Coatings on Metals:

- ◆ *System consists of: Epoxy primer, Epoxy or urethane intermediate coat, Fluoro-urethane polymer top coat. Specify each for each project condition.*

Coatings on Floors:

- ◆ *System consists of: epoxy primer, Epoxy intermediate, plus epoxy or urethane top coat. Specify each for each project condition.*

Specialties

DIVISION 10

Contents

- 10-02 10 1101 – Visual Display Boards
- 10-03 10 1146 – Visual Display Wallcovering
- 10-04 10 1147 – Tackable Wallcovering
- 10-05 10 1447 – Wayfinding and Emergency Egress Signage
- 10-05 10 2113 – Toilet Compartments
- 10-06 10 2800 – Toilet Accessories
- 10-06 10 5523 – Mail Boxes
- 10-06 11 5300 – Laboratory Equipment

10-01

List of Figures

- 10-07 *fig. 10a: Campus Standard Toilet Accessory Model Numbers*

SPECIALTIES

Most assemblies and items that fall into the Division 10 heading are manufactured products that frequently change model numbers etc. The following is written in effort to establish the quality expected for a project and in general model/ product numbers are only used in cases where the University stocks a particular item that they wish to continue using in ongoing maintenance and operations.

10 1101 – Visual Display Boards

TYPICAL ASSEMBLIES TO WHICH THIS SECTION PERTAINS

Markerboards, magnetic markerboards, chalkboards, tackboards and fabric covered tackboards.

QUALITY ASSURANCE

Visual display boards and their associated hardware and accessories shall be by the same manufacturer to ensure that pieces fit together.

Provide a lifetime warranty for porcelain enamel steel markerboard and chalkboard writing surfaces when installed per manufacturer instructions.

- ◆ *Warranty shall cover replacement of defective boards due to discoloration, excessive fading, crazing, cracking or flaking.*

MATERIALS

Marker Boards:

- ◆ *Writing surface, ASTM A 424, Type 1, Porcelain enamel on steel.*
- ◆ *Metal face sheet thickness: 0.024 inch (24 gage)*
- ◆ *Hardboard face sheet thickness: at least ¼ inch*
- ◆ *Core: either particleboard or mdf laminated to face sheet.*
- ◆ *Backing: 0.005 inch thick aluminum foil, laminated to core.*
- ◆ *Accessories: One marker holder kit for every 12 linear feet of marker board or one for each wall whichever is more, consisting of wall caddy (metal), 4 different colored markers, 1 eraser and 8 ounces of cleaning fluid.*

TACK BOARDS

- ◆ *Exposed tack surface: 0.25 inch thick composite cork linoleum laminated to 0.25 inch hardboard back with flame spread index of not more than 25 (Class A), and smoke developed index of not more than 450 when tested in accordance with ASTM E 84.*

SPECIALTIES

FACTORY ASSEMBLED UNITS

- ◆ *Laminate facing sheet and backing sheet to core material under pressure, using manufacturer's recommended adhesive.*
- ◆ *Where butt jointed spliced panels are required use MDF core.*
- ◆ *Provide factory-assembled visual display boards, except where sizes demand partial field assembly*
- ◆ *Assemble units in one piece without joints, wherever possible. Where required dimensions exceed maximum panel size available, provide two or more pieces of equal length, as indicated on approved shop drawings. Assemble to verify fit at factory, then disassemble for delivery and final assembly at project site.*

10 1146 – Visual Display Wallcovering

TYPICAL ASSEMBLIES TO WHICH THIS SECTION PERTAINS:

Dry erase wallcovering, projection wall covering, combination dry erase and projection wallcovering.

10-03

QUALITY ASSURANCE

- ◆ *Design consideration: avoid having a seam in the middle of the writing surface as it is more difficult to clean and results in dark lines at the butt joints. It is best to use 60 inch wide rows which are located 30-36 inches above the floor. If the viewing/projecting surface needs to be extended up and/or down, narrower roles of the same material may be used above or below the 60 inch role material.*
- ◆ *Applicator: Installation by skilled commercial wallcovering applicators with no less than three years of documented experience installing dry erase wallcovering of the types and extent required.*
- ◆ *Substrate: for most of the materials used in this section, the preparation of the wall surface is as important as the actual installation of the material. Ensure that all contract work associated with the final outcome of this installation is carefully coordinated and mutual responsibilities are understood by all parties.*

MATERIALS

- ◆ *All materials in this assembly shall meet the ASTM E 84 requirements for the material class required by the NCBC for the space*

in which the finish is going.

- ◆ *Sheet materials are typically a vinyl surface for dry erase markers with a woven backing.*
- ◆ *Surfaces for projection are typically a different coating to minimize reflections and maximize visibility.*
- ◆ *Edges are typically captured with an aluminum trim that allows the feathered edge material to be concealed on all sides.*
- ◆ *Heavy duty clear premixed vinyl adhesive as required by the role manufacturer shall be used on the project.*
- ◆ *Marker caddy: One marker holder kit for every 12 linear feet of marker board or one for each wall whichever is more, consisting of wall caddy (metal), 4 different colored markers, 1 eraser and 8 ounces of cleaning fluid.*

10 1147 – Tackable Wallcovering

10-04

TYPICAL ASSEMBLIES TO WHICH THIS SECTION PERTAINS:

Resilient cork or linoleum wallcovering.

QUALITY ASSURANCE

Applicator: Installation by skilled commercial wallcovering applicators with no less than three years of documented experience installing dry erase wallcovering of the types and extent required.

Mock-ups are beneficial and should generally be required for this section to establish requirements and expectations for seaming, trim installation and edge conditions.

MATERIALS

Multi-colored, homogeneous tackable surface consisting of through-body color, and at least 30% recycled content.

Rolls of material are generally 4 feet wide.

Edges are usually captured by an aluminum J-trim of clear anodized aluminum.

SPECIALTIES

10 1447 – Wayfinding and Emergency Egress Signage

EMERGENCY EGRESS AND EMERGENCY RESPONSE PERSONNEL

Recommended emergency procedures should be conspicuously located on each floor near each vertical exit element and/ or elevator in each building.

Emergency response and egress elements should be consistently labeled and comprised of consistent graphics in effort to aid identification and interpretation of response personnel.

WAYFINDING

The Wake Forest Reynolda campus is used for many conferences and camps to which visitors frequent en masse in the summer time. For this reason and for general safety of building occupants way finding should be consistently rendered across campus and conspicuously located.

10 2113 – Toilet Compartments

10-05

TYPICAL ASSEMBLIES TO WHICH THIS SECTION PERTAINS:

Toilet compartments and urinal screens.

QUALITY ASSURANCE

- ◆ *Design team shall coordinate to ensure there is adequate structural support for partitions in or above the ceiling assembly.*
- ◆ *Particular attention shall be paid to accessibility requirements for toilet room layout concerning turning spaces, accessible approaches and clearances.*
- ◆ *Discuss with F&CS whether ceiling hung or floor mounted compartments are more appropriate or preferred.*

MATERIALS

Toilet partitions and urinal screens shall be manufactured of stainless steel or solid phenolic.

Stainless steel partitions:

- ◆ *The steel sheet shall be composed of Type 304 stainless steel, minimum 22 gage with a #4 finish.*
- ◆ *Doors shall be at least 58 inches tall.*
- ◆ *Pilaster shall be at least 1 ¼ inch thick.*
- ◆ *Panels and doors are to be at least 1 inch thick.*

SPECIALTIES

- ◆ *Brackets shall be cast of non-ferrous metals and chrome plated.*

Phenolic partitions

- ◆ *Phenolic partitions may be either a solid core color consistent with the face finishes or a black core with color specified finish.*
- ◆ *In either case, the material shall be no less than ¾ inch thick.*
- ◆ *Doors shall be at least 58 inches tall.*
- ◆ *Mounting hardware and door hardware shall be stainless steel.*
- ◆ *All doors shall be equipped with a stainless steel coat/bag hook on the toilet side of the door.*

10 2800 – Toilet Accessories

TYPICAL ITEMS TO WHICH THIS SECTION PERTAINS:

WFU maintains the various dispensers and receptacles throughout campus and is set up to work with specific manufacturer's products. It is imperative that each project fit out toilet rooms according to the University standards. ***Refer to figure 10a: Campus Standard Toilet Accessory Model Numbers, opposite page.***

10-06

10 5523 – Mail Boxes

TYPICAL ITEMS TO WHICH THIS SECTION PERTAINS:

Wake Forest University maintains a central Mail Service department. Student mail boxes exist in the Benson Center as P.O. Boxes and need not be considered in residence hall projects. Similarly faculty and staff mail distribution is from Mail Services to the individual departments and then is distributed by department from there.

11 5300 – Laboratory Equipment

TYPICAL ITEMS TO WHICH THIS SECTION PERTAINS:

Refrigerators, freezers, sterilizers, glass washers, ice makers, incubators, bio safety cabinets, centrifuges and other easily moveable or portable lab equipment items will generally be purchased and installed by the Owner but must be carefully considered by the design team in the programming and development of the contract documents.

Items in this section will be specific to each project and application. The University, in particular EH&S and user groups will have specific requirements.

SPECIALTIES

QUALITY ASSURANCE:

Special attention should be paid to electrical requirements, vibration issues, how much heat equipment will give off, other utilities or services that may be required for example steam, carbon dioxide, polished water and natural gas.

*fig. 10a: CAMPUS STANDARD TOILET ACCESSORY MODEL NUMBERS
WFU maintains the various dispensers and receptacles throughout campus and is set up to work with specific manufacturer's products. It is imperative that each project fit out toilet rooms according to the University standards.*

Plumbing	Model #
Delta	
Lavatory Faucets "No Pop-Up"	500-WF
Kitchen Faucet	400-WF
Shower Faucet	1323
Delta ADA Slide Bar w/ Sprayer	RP32539
Halsey Taylor Water Fountain bi-level with bottle fill	HTHB-HAC8BL-WF-PV Hydro Boost W/HAC Bi-Level
Halsey Taylor Water Fountain single level with bottle fill	HTHB-HAC8BL-WF-PV Hydro Boost W/HAC

Flush Valves	Model#
Sloan Closet	WES111
Sloan Urinal	186-1
"No Pressure Assisted Toilets"	
Urinals	
Sloan .13GPF	SU1000
"No Waterless Urinals"	
Watco Drain	800-PP-BRS-CP

Dispensers

Bay West	Model #
2 Roll TP "NOT FOR DORMS"	7220
Roll Towels "NOT FOR DORMS"	76500
Bay West Dispensers are provided by Bay West at no charge	

Stainless Steel 2 Roll TT, by GP	57893
Stainless Multi-Fold Dispensers, by Bobrick	B-262
"For Dorms Only" All dispensers my work with current keys used now	

GoJo Soap Dispensers	5150-06
Dispensers are provided by GOJO	

Equipment

DIVISION 11

Contents

11-02 11 5300 – Laboratory Equipment

11-02 11 5313 – Laboratory Fume Hoods

EQUIPMENT

Most assemblies and items that fall into the Division 11 heading are manufactured products that frequently change model numbers etc. The following is written in effort to establish the quality expected for a project and in general model/ product numbers are only used in cases where the University stocks a particular item that they wish to continue using in ongoing maintenance and operations.

11 5300 – Laboratory Equipment

TYPICAL ITEMS TO WHICH THIS SECTION PERTAINS

Refrigerators, freezers, sterilizers, modular stainless steel walls, glass washers, ice makers, incubators, bio safety cabinets, centrifuges and other easily moveable or portable lab equipment items will generally be purchased and installed by the Owner but must be carefully considered by the design team in the programming and development of the contract documents.

QUALITY ASSURANCE

Special attention should be paid to electrical requirements, vibration issues, how much heat equipment will give off, other utilities or services that may be required for example steam, carbon dioxide, polished water and natural gas.

MATERIALS

Water Saver or Broan plumbing fixtures are preferred and shall be either epoxy or powder coated.

Bradley and Guardian is acceptable for eyewashes and emergency showers.

11 5313 – Laboratory Fume Hoods

TYPICAL ITEMS TO WHICH THIS SECTION PERTAINS

Fume hoods, fume hood work surfaces, fume hood base cabinets, accessories for fume hoods and fume hood commissioning.

QUALITY ASSURANCE

Fume hoods shall comply with the requirements of SEFA 1 “Laboratory Fume Hoods – Recommended Practices”.

Provide factory testing of each type of hood specified to demonstrate fume hood performance. Provide testing facility, instruments equipment and materials needed for tests.

EQUIPMENT

For submittals, detailed shop drawings including rough-in requirements are essential for field coordination.

Fume hoods shall be certified to be in compliance with ASHRAE Std 110.

Wake Forest's Environment Health & Safety group shall be consulted when designed for fume hoods.

MATERIALS

Whether or not cabinets are wood or metal will be determined on a project by project basis.

Hoods may be 4, 5, 6 or 8 feet wide but are most often 4 feet in teaching settings.

SASH

Vertical rising, minimum $\frac{1}{4}$ inch thick laminated safety glass, epoxy coated steel track with single counterbalance weight.

Factory installed sash stops, permanent, cam style.

Furnishings

DIVISION 12

Contents

12-02 12 2413 – Window Shade Systems

12-03 12 3000 – Countertops

Most assemblies and items that fall into the Division 12 heading are manufactured products that frequently change model numbers, etc. The following is written in effort to establish the quality expected for a project and in general model/ product numbers are only used in cases where the University stocks a particular item that they wish to continue using in ongoing maintenance and operations.

12 2413 – Window Shade Systems

TYPICAL ITEMS TO WHICH THIS SECTION PERTAINS

Manually operated window shades and motorized window shades.

The systems in this section are for general building solar and light control. Any shade systems wider than 8 feet and taller than 7 feet exceed the design parameters set forth herein and should be very carefully specified with the help of a manufacturer.

QUALITY ASSURANCE

- ◆ *Motorized window shade control: Wall switch control is standard. Remote control and A/V integrated control are also common. Further research is required if specifying sun or light sensed control or building automation system integrated control.*
- ◆ *Show typical mounting detail at mounting location.*
- ◆ *Locate shades and types on drawings.*
- ◆ *Specify percent transparency and color of shades.*
- ◆ *Install window shades after finish work especially drywall and painting is complete.*

MATERIALS

In general, well-known and trusted manufacturers of products are preferred on Wake Forest University projects. With that in mind, the following manufacturers would be accepted:

- ◆ *Mechoshade: www.mechoshade.com*
- ◆ *Nysan: www.nysan.com*
- ◆ *Draper: www.draper.com*

Manually operated window shade systems

- ◆ *Chain Operation: Bi-directional wrap spring clutch shall allow for shade to stop and hold at any position.*
- ◆ *Bead Chain: No. 10 stainless steel.*

FURNISHINGS

- ◆ *Clutch mechanism: Fabricated from high carbon steel. Components fabricated from styrene based plastics, polyester or reinforced polyester are not acceptable.*

Motorized window shade system

- ◆ *Operation: Motorized control system shall allow for shades to be in fully up or fully down position, one stop position aligned with horizontal mullion, and shall allow for local override.*
- ◆ *Solar Control: Shades on different elevations within one room or open space shall operate independently.*
- ◆ *Control requirements will be determined per project.*

Shade Components

- ◆ *Rollers: Shade roller tube shall be extruded aluminum of diameter and wall thickness required to support shade fabric. Maximum allowable deflection $L/700$.*
- ◆ *Mounting Brackets: Stamped steel, custom fabricated as required for mounting style indicated.*
- ◆ *Hembar: concealed.*

Accessories

- ◆ *Fascia: L-shaped extruded aluminum shall conceal mounting hardware, roller tube, and fabric rolled on tube.*
- ◆ *Pocket: Extruded aluminum shall conceal mounting hardware, roller tube and fabric rolled on tube.*
- ◆ *Fascia/Pocket End Caps: Provide end caps where mounting conditions expose outside of roller shade brackets.*

12 3000 – Countertops

TYPICAL ITEMS TO WHICH THIS SECTION PERTAINS

Laboratory Countertops and Shelving

MATERIALS

- ◆ *Countertops - 1 inch to 1 ¼ inch thick, epoxy unless phenolic is specifically otherwise approved by the University.*
- ◆ *Shelving – ¾ inch to 1 inch thick, may be epoxy or phenolic.*

Conveying Equipment

DIVISION 14

Contents

- 14-02 Conveying Equipment
- 14-02 Specific Parameters
- 14-03 Specific Elevator Car/Function Requirements

Conveying Equipment

The University maintains a 5-year service contract for the entire campus for elevator systems. For new elevators, where possible, the University prefers machine room-less, all hoist-way contained conveyance systems.

Specific Parameters

The following guidelines apply to new and renovated structures:

- ◆ *NO new in-ground hydraulic systems allowed on campus.*
- ◆ *When machine room less, disc or belt drive systems cannot be used due to load capacity etc., hole-less hydraulic elevators may be considered. When hydraulics are a must, they must be organic fluid driven.*
- ◆ *Elevator machine rooms shall be adjacent to and share a wall with the elevator shaft.*
- ◆ *Shaft venting and pressurization is to meet all applicable codes.*
- ◆ *Power receptacles and lighting are to be provided at the top and bottom of all shafts regardless of whether code requires them.*
- ◆ *Handicap lifts are NOT allowed in new construction; only in approved renovation applications.*
- ◆ *Dumbwaiters are NOT preferred; however, the University acknowledges their value in limited applications. These will be considered only on a case by case basis, for example, the University Post Office and the University Corporate Center.*
- ◆ *Dock levelers are required at all loading docks.*

CONVEYING EQUIPMENT

Specific Elevator Car/Function Requirements

The following guidelines apply to new and renovated elevators:

- ◆ *Lighting shall be LED technology.*
- ◆ *Finish shall be brushed stainless steel.*
- ◆ *Flooring must be easily maintainable – preference is vinyl composition tile.*
- ◆ *Ceiling finishes will vary by project.*
- ◆ *Residence Life has their own elevator cab requirements – consult with the department.*
- ◆ *All elevators shall have a direct line of communication to Campus Police dispatch.*
- ◆ *All elevators shall have an emergency phone.*
- ◆ *All elevators shall have ADA compliant controls.*
- ◆ *All elevators shall be configured and controlled for fire department access from the primary level of fire department access. Where not backed up by an emergency generator, provide dedicated battery back-up.*

Fire Suppression

DIVISION 21

Contents

21-02	Codes And Standards
21-02	Basic Requirements
21-04	21 00 00 Common Work Results For Fire-Suppression
21-04	21 05 53 Identification For Fire-Suppression Piping And Equipment
21-05	21 08 00 Commissioning Of Fire Suppression
21-06	21 10 00 Water-Based Fire-Suppression Systems
21-06	21 10 10 Facility Fire-Suppression Water-Service Piping
21-08	21 12 00 Fire-Suppression Standpipes
21-08	21 13 13 Wet-Pipe Sprinkler Systems
21-13	21 13 16 Dry-Pipe Sprinkler Systems
21-14	21 13 19 Pre-Action Systems
21-14	21 13 39 Foam-Water Systems
21-14	21 20 00 Fire-Extinguishing Systems
21-14	21 30 00 Fire-Pumps
21-17	21 34 00 Pressure-Maintenance Pumps (Jockey Pumps)

Codes And Standards

- ◆ *NFPA 13 Sprinkler Systems*
- ◆ *NFPA 13R Sprinkler Systems (as approved by AHJ)*
- ◆ *NFPA 14 Standpipe and Hose Systems*
- ◆ *NFPA 20 Centrifugal Fire Pumps*
- ◆ *NFPA 24 Private Fire Service Mains*
- ◆ *NFPA 25 Inspection., Testing, and Maintenance of Water-Based Fire Protection Systems*
- ◆ *NFPA 72 National Fire Alarm Code*
- ◆ *North Carolina Building Code*
- ◆ *Local Requirements of the Winston-Salem Fire Marshall*

The designer shall use the version of the referenced NFPA standard required by the current version of the NC Building Code unless otherwise approved by the Authority Having Jurisdiction.

The Authority Having Jurisdiction (AHJ) is the Winston-Salem Fire Marshal.

Basic Requirements

In every project, the Design Team is responsible for performance of the proposed system and shall insure that the designed equipment will integrate and operate satisfactory with resources available. When any of the existing building systems are expanded and new equipment added, the Design Team must verify utilities present and advise the University if the existing capacities will adequately support the proposed design without undermining the current facility performance or report if upgrading of existing infrastructure shall be necessary.

RENOVATION PROJECTS:

Contract Documents shall address occupancy and facility use during construction process, specific requirements regarding phasing, restrains on schedules, restrictions on utilities disconnect, existing systems protection, and other constrains applicable for each and every discipline.

When the building will be occupied during construction, the Design Team shall stress that all existing building safety systems such as exit signage, exit lights, fire alarm, fire sprinkler etc must remain operational CONTINUOUSLY in order to retain building occupancy status. All required exits and exit signs must be kept available and free of obstruction at all times.

FIRE SUPPRESSION

Specify dust and noise control during construction activities especially to protect occupied areas. Denote drawings regarding protection of existing ductwork system against contamination from dust and debris.

Provide demolition plans for each discipline with clear indication of equipment and part of the system being removed. Identify any items that need to be salvaged and returned to the Owner. Specify any parts or materials that shall be recycled.

Performance specifications shall be used. Where a manufacturer is listed on the drawings as the basis of design, two additional manufacturers capable of providing the product shall also be listed on the drawings.

Fire Protection drawings and specifications shall be sealed by the design engineer of record registered in the State of North Carolina. If more than one professional seal is required for the specifications (such as if there are multiple disciplines), indicate the Divisions for which each professional is responsible. Seals shall appear on all submissions as a means of identifying the responsible engineer. Professional seals identifying the “author” and/or the “Designer of Record” shall be affixed to all drawings, specifications and other technical submissions. Construction documents shall include the name and address of the business entity (individual, corporation, or partnership) with whom the registered design professional is affiliated. Seals must be signed on documents submitted for Working Drawing/Construction Document (100% complete) review.

Piping and head locations are NOT required to be part of the Construction Documents. Such layouts shall be denoted as being provided for general coordination and information only.

The Specifying Engineer (PE) has primary responsibility for review and approval of fire suppression system shop drawings and hydraulic calculations. Specifying Engineer shall review and determine compliance with applicable codes and standards and the project contract documentation

Shop drawings shall be submitted with format and content consistent with NFPA 13. Shop drawings shall be accompanied with Hydraulic Calculation Forms, per NFPA 13.

In the event of a renovation outside of the Remote Area, Designer shall identify the Remote Area and its location relative to the renovation area. Use of a key plan for this remote area identification is acceptable.

Installation drawings shall be prepared under the supervision of qualified “design professional” who can be a Professional Engineer (PE) registered in North Carolina or a minimum Level III technician certified in Fire Protection Engineering Technology and Automatic Sprinkler System Layout by the National

FIRE SUPPRESSION

Institute for Certifications in Engineering Technologies (NICET). Submittals, drawings, and hydraulic calculations shall bear the PE seal or NICET certification number and signature.

Contractor License, Qualifications, and Responsibilities: The contractor must be licensed by the North Carolina State Board of Examiners of Plumbing, Heating, and Fire Sprinkler Contractors.

The Building Code Summary shall be included on the first sheet of the plan set.

All drawings shall include a graphic scale.

A complete Fire Protection symbol schedule and abbreviation legend shall appear on the first drawing sheet for each respective discipline.

All floor plans and enlargements of floor plans shall bear North arrows, room names, room numbers, and column lines. All floor plans and enlargements shall have the same directional orientation. Site plans and floor plan directional orientation shall agree.

Indicate the location and rating of all fire/smoke rated walls on all plans, including shop drawings, using NCBC definitions of wall, barrier, or partition. Provide a legend for the symbols used. Fire and smoke ratings shall match the architectural design and be consistent throughout the project

Provide current UL listed details of penetrations through rated assemblies. Include the UL design number.

Fire-suppression equipment room layouts shall be arranged to provide access for removal, servicing, and maintenance of all equipment.

Fire-suppression equipment room and fire pump room enlargements and sections (1/4"=1'-0" minimum) shall be provided.

Fire-suppression equipment riser rooms and fire pump rooms should be placed at ground level and preferably away from occupied spaces to minimize transmission of vibrations and sound into the building.

Fire-suppression equipment riser rooms and fire pump rooms shall be designed to have direct access from the outside.

21 00 00 Common Work Results For Fire-Suppression

The Fire Protection Contract shall begin one foot above the finished floor inside the building and shall be delineated on the drawings.

21 05 53 Identification For Fire-Suppression Piping And Equipment

All control, drain, and test connection valves shall be provided with permanently marked weatherproof metal or rigid plastic identification signs.

FIRE SUPPRESSION

Indicate that all Fire-Suppression lines outside building footprint shall be required to have a warning tape installed in the backfill between 6 inches to 24 inches below finished grade, directly over piping.

- ◆ *Metallic lines shall be identified with printed durable plastic warning tapes, minimum 3" wide, with lettering to identify buried line below.*
- ◆ *Non-metallic pipes shall be identified by detectable warning tapes, minimum 2" wide, with lettering to identify buried lines below.*

21 08 00 Commissioning Of Fire Suppression

INSTALLATION, TEST, AND CERTIFICATION

All sprinkler valves and controls must be located for safe and convenient access during emergencies and testing. Control valves shall not be located above ceilings.

Inspector's Test Connections should be operable from floor level. Where control valves must be located more than 7 feet AFF, provision for access shall be provided (e.g., permanent ladder/catwalk or, if the AHJ permits, a chain-operated valve).

Identify each valve and control with a prominent engraved phenolic or stamped metal placard. Any such devices that are behind access doors or panels must also have their location made known by an appropriate placard on the means of access.

CONTRACTOR'S MATERIAL AND TEST CERTIFICATES

- ◆ *The contractor shall thoroughly inspect completed system to assure compliance with the engineer's plans and applicable Codes and Standards.*
- ◆ *Pressure tests shall be done with all sprinkler heads installed. Where an existing sprinkler system is being expanded or renovated, the contractor is responsible for the integrity of all new piping plus existing piping within three feet of new or renovation work, and the owner is responsible for the integrity of the balance of the system, during the pressure test.*

Prior to final inspection by the AHJ and/or the owner's representative, the

FIRE SUPPRESSION

system installer is to submit NFPA-required Contractor's Material and Test Certificate(s) for aboveground, and underground, piping

Interior Piping Test: Hydrostatically test all interior piping and appurtenances in accordance with NFPA 13. The system shall hold 200psi for 2 hours without any water leakage. Record results and submit test report documentation.

Additional Air Test for Dry Pipe Systems. Pump the system to 40psi and allow it to stand for 24 hours. The air pressure must not leak down more than 1.5psi. Record results on the Contractor's Material and Test Certificate.

Additional Operating Test for Dry Pipe Systems: All dry pipe systems must deliver sustained water flow to the inspector's test connection within sixty (60) seconds. Record the actual time on Contractor's Material and Test Certificate.

Fire/Booster Pump Acceptance Test (Performance Test): The fire pump must have a field acceptance test in accordance with NFPA 20. This test must include the pump manufacturer, the engine manufacturer (if provided), controller manufacturer, and transfer switch manufacturer (if provided).

SYSTEM DOCUMENTATION, OWNER TRAINING, AND SPARE PARTS:

Documentation

The contractor shall supply the owner with two (2) copies of the approved shop drawings. Locations of all control valves and operating instructions shall be permanently mounted at the sprinkler riser or fire pump.

The manufacturer's representative must instruct the owner's designated employees in operation of the system, and in all required periodic maintenance. A minimum of 2 hours on-site time will be allocated for this purpose.

Spare Parts

The following spare parts should be provided with the system in addition to the required sprinklers.

- ◆ *Special/Custom Escutcheons same as required sprinklers*
- ◆ *Special/Custom Cover plates same as required sprinklers*

21 10 00 Water-Based Fire-Suppression Systems

Data Rooms. A designer's option to propose an alternate suppression system for a data room, in accordance with NCFPC is subject to the approval by the fire code official.

21 10 10 Facility Fire-Suppression Water-Service Piping

Provide site plan showing fire water connection to main. Indicate location

FIRE SUPPRESSION

of the Back Flow Preventer (BFP), Post Indicator Valve (PIV), Fire Department Connection (FDC), fire pump test header (if applicable), exterior sprinkler alarm, and adjacent Fire Hydrants (FH).

- ◆ *Shut off valves at BFP shall be provided with tamper switches for monitoring.*
- ◆ *At least one listed and properly supervised indicating valve (PIV) shall be installed in source of the fire water supply*
- ◆ *PIV shall be located 40 feet from building walls where space allows, unless other arrangements are made and approved by the local authorities.*
- ◆ *PIV shall include tamper switches or monitoring devices.*
- ◆ *FDC shall be located on the system side of the water supply alarm check valve.*
- ◆ *FDC shall be provided with listed check valve and no shutoff at connection piping to the system. The piping between the check valve and the outside hose coupling shall be equipped with an approved automatic drip.*
- ◆ *FDC shall be located within 100' of a fire hydrant or as approved by AHJ.*
- ◆ *FDC shall be readily accessible and not located on loading docks or under a building overhang, behind fence or inside enclosed mechanical yard.*
- ◆ *FDC should be located not less than 18 in. and not more than 4 ft above the level of the adjacent grade or access level and, if yard type, shall be reinforced by a concrete pad at the ground penetration.*

PIV and FDC shall meet local AHJ standard and detail installation.

Backflow Prevention Devices. Device shall be located inside and shall be double check type. Provide a cutoff valve on both sides of the backflow prevention device in the water supply connection, for isolation (servicing). Where a booster pump is installed, the backflow assembly, required by water quality regulations to be on the suction side, must be located as far from the pump intake as possible (at least 10 pipe diameters).

Valve Types. An outside post indicator type control valve (PIV) must be provided for all systems. All indoor cutoff valves in the two (2) inch through eight (8) inch range shall be the butterfly type, with integral tamper switch and valve position indicator.

FIRE SUPPRESSION

Fire Protection Main/Riser. Fire protection main piping should enter the building as close to the exterior as possible. The fire protection main piping should not be routed through the building.

The fire sprinkler contractor shall repeat the hydrant flow test after the bid to aid in developing hydraulic calculations and shop drawings.

Fire main flushing and pressure testing shall be conducted in accordance with NFPA 24.

Flushing: Underground pipe shall be thoroughly flushed before being connected to sprinkler system in accordance with NFPA 24.

Hydrostatic Test is typically 200psig for two hours in accordance with NFPA 13 and 24. Provide certification per NFPA 24.

21 12 00 Fire-Suppression Standpipes

Standpipes shall be provided in accordance with the NCFPC.

21 13 13 Wet-Pipe Sprinkler Systems

Fire sprinkler system design shall be shown on fire protection plans, and not included on floor plans of other trades.

Although fire sprinkler sizing and piping layout is allowed to be provided by the contractor in form of shop drawings, the Specifying Engineer is responsible for preparing criteria documents with “standard of care” which shall include design drawings containing sufficient information to indicate compliance with codes and to insure that the installing contractor will not have to make design decisions. Risers, control valves, and main drains shall be shown on the floor plan(s).

Plans and Specifications Content. This information defines the system’s performance, major features, and acceptable materials. The following design details do not include pipe sizes, head locations, or hydraulic calculations. Plans shall include the following for a performance design:

Water supply test data (static pressure, residual pressure, flow, date and time of test) taken within one year. Identify the hydrants used, their elevation, and elevation of riser base.

Indicate the locations and elevations of the flow and pressure test hydrants on a site utility plan. Reference NFPA 13 for the water test procedure.

Designer must specify that the sprinkler contractor must verify the water supply by test, using 2 hydrants as close to the point of connection as possible, may be witnessed or performed by a fire official. Contact water authorities before test, to verify normal system status and to determine typical fluctuations in

FIRE SUPPRESSION

available pressure/flow at that location due to tank fill, pump status, industrial demand. Base design on 10psi less residual pressure and 10% less available flow than test results. Calculations start at water main connection under street and must include backflow preventer plus all valves and fittings. Use “1.4 Rule” and include hose stream allowance specified by NFPA 13 for that hazard.

Provide a fire sprinkler design summary table with, at the minimum, the following information for each fire sprinkler zone: system type (wet, dry, pre-action, deluge), hazard classification, water application density, and hose allowance.

Minimum Design Density. The hazard for each individual area shall be analyzed prior to determining sprinkler density, using NFPA 13. Ordinary Hazard Group 1 is minimum system design normally accepted. Each protected area shall be analyzed independently to determine the greatest hazard present.

MISCELLANEOUS STUDENT RESIDENCE HALLS, DORMITORIES AND APARTMENT SPRINKLER REQUIREMENTS

Portable wardrobe units do not require sprinklers to be installed inside them. Although the units may be fastened to the finished structure, they are considered by NFPA to be furniture rather than a part of the structure; thus sprinklers are not required. This was from a clarification provided in the 2007 Edition of NFPA13.

New Residence Halls, Dormitories and Apartments. If less than 12 SF, closets are not required to be sprinklered, unless such closet contains equipment such as washers, dryers, furnaces, or water heaters.

Existing Residence Halls, Dormitories and Apartments. If less than 24 SF, closets are not required to be sprinklered, unless such closet contains equipment such as washers, dryers, furnaces, or water heaters.

System Zoning Requirements. Each story must be a separate sprinkler zone with a dedicated cutoff valve, tamper switch, water flow switch, and an Inspector’s Test valve, typically referred to as a Floor Control Assembly, piped to a drain capable of handling full flow without backup or splatter. All Floor Control Assemblies, cutoff and test valves are to be located on the floor they serve, unless the AHJ permits a different arrangement.

NOTE: For buildings of more than 12 floors, consider two risers, separated from one another and located within stairways or otherwise protected from fire. Each riser would serve either: (1) Alternate floors, or (2) Roughly half of each floor. Where the floors are divided by smoke or fire barriers/partitions, we recommend option (2) if the sprinkler zone boundaries could reasonably correspond

to smoke or fire barriers/partitions.

Water motor-operated devices should be located as near as practicable to the alarm valve, dry pipe valve, or other waterflow detecting device. The total length of the pipe to these devices should not exceed 75 ft nor should the water motor-operated device be located over 20 ft above the alarm device or dry pipe valve.

Per NFPA13 electrical supervision per NFPA 72 is required for monitoring the position of all sprinkler cutoff valves beyond the water source valve, including the outside post indicator valve (PIV) and isolation valves for the backflow prevention device. Tamper switches for OS&Y valves shall be mounted to rigid frames secured by bolts through clamp bars. Coordinate with electrical design for monitoring the tamper switches by the Fire Alarm Panel. Show tamper switches and waterflow switches on electrical plans and fire alarm matrix.

Electrical supervision per NFPA 72 is required for monitoring the position of all sprinkler cutoff valves beyond the water source valve, including the outside post indicator valve (PIV) and isolation valves for the backflow prevention device. Tamper switches for OS&Y valves shall be mounted to rigid frames secured by bolts through clamp bars.

Separate pump houses, unconditioned spaces containing wet pipe sprinkler systems and hot boxes shall include a temperature-sensing switch to monitor for low temperatures. A fire alarm system “supervisory” signal shall be initiated for temperatures of 40°F (5°C) or lower.

Dry pipe and pre-action system air supply must also be monitored, for both low and high pressure. Provide a “block and bleed” type ball valve to facilitate testing and adjustment of supervisory switches. A fire alarm supervisory signal shall be initiated for air pressure above maximum set point or below minimum set point.

Per NFPA 13 Chapter 8, where aboveground water-filled supply pipes, risers, system risers, or feed mains pass through open areas, cold rooms, passageways, or other areas exposed to temperatures below 40°F, the pipe shall be protected against freezing by insulating coverings, frostproof casings, listed heat tracing systems, or other reliable means capable of maintaining a minimum temperature between 40°F and 120°F. Supervision is required for heat tracing. Heat tracing shall be approved by AHJ.

Specify that sprinkler heads be centered in ceiling tiles. Showing heads on floor plan is optional and may be left to contractors shop drawing submittal

FIRE SUPPRESSION

SPRINKLER HEADS

Quick Response (QR) sprinkler heads shall be used in all sleeping rooms and laboratories

Residential sprinklers are not to be used in dry systems, unless listed for dry system use.

Address on plans sprinkler requirements at the exterior canopies, decks and any open spaces under the roof to comply with NFPA 13 Chapter 8.

Heads shall be rated at 155F except in mechanical equipment spaces, where they shall be rated at 200F.

Sprinkler heads shall be as manufactured by Tyco, Viking, Globe or equivalent manufacturer.

STAIRS

Sprinklers shall be installed beneath each landing at all stairways of combustible construction

In noncombustible stair shafts having noncombustible stairs with noncombustible or limited combustible finishes, sprinklers shall be installed at the top of the shaft and under the first landing above the bottom of the shaft.

Sprinklers shall be installed beneath landings or stairways where the area beneath is used for storage.

Sprinklers shall be permitted to be omitted from exterior stair towers when the exterior walls of the stair tower are at least 50 percent open and when the stair tower is entirely of noncombustible construction.

ELEVATOR HOISTWAYS AND MACHINE ROOMS

Sidewall spray sprinklers shall be installed at the bottom of each elevator hoistway not more than 2 ft above the floor of the pit.

Sprinklers are not required for enclosed, noncombustible elevator shafts that do not contain combustible hydraulic fluids.

Automatic sprinklers in elevator machine rooms or at the tops of hoistways shall be of ordinary- or intermediate-temperature rating.

Upright, pendent, or sidewall spray sprinklers shall be installed at the top of elevator hoistways. (Sprinkler at the top of the elevator hoistway shall not be required where the hoistway for passenger elevators is min 1-hr rated noncombustible and the car enclosure materials meet the requirements of ASME A17.1, Safety Code for Elevators and Escalators).

CONCEALED SPACES

Noncombustible and limited combustible concealed spaces with no access and no storage shall not be required to be sprinklered.

Attics or crawl spaces where mechanical equipment requiring service is installed shall be sprinklered.

SPRINKLER PIPING

All Sprinkler system materials and components must be listed or approved, and installed in strict conformance to the conditions of their listing/approval.

- ◆ *Metal: Only steel pipe shall be used, with a Corrosion Resistance Ratio (CRR) of one (1) or greater. Schedule 5 pipe is not permitted. Schedule 10 steel pipe and the approximately equal “flow” products, sizes 1.5” and larger, are permitted to be used only with listed roll groove end fittings. All dry pipe, deluge, and pre-action system pipe must be galvanized, including any fittings exposed to weather.*
- ◆ *In all dry and preaction sprinkler system, internally galvanized pipe is required.*
- ◆ *Plastic: Listed, approved CPVC sprinkler pipe is permitted ONLY upon prior approval from WFU and the local AHJ.*

FITTINGS AND JOINTS.

All fittings must be listed or approved for the specific pipe and type of system they are used on. For gasketed fittings, install only with the lubricant the manufacturer obtained listing with, since other lubricants may not provide suitable performance. Note: Plain end, hooker, press-on, key-type, or slip-type fittings are not permitted. All grooved metal products on a job (including both fittings and couplings) must be products of the same manufacturer, as mixing different brands may result in leaks or failures due to variations in design dimensions or production tolerances.

Metal: The following joining methods are acceptable for steel pipe, to the extent permitted by listings, except that threading or cut groove fittings are accepted only for use on fully complying Schedule 40 and heavier pipe:

- ◆ *Threading*
- ◆ *Shop Welding*
- ◆ *Cut Groove with Gasket Fitting*
- ◆ *Roll Groove with Gasket Fitting*

FIRE SUPPRESSION

- ◆ *Full Back Design Clamp-on Fittings*
- ◆ *“U” Bolt Design Clamp-on Fittings (Only for pipe of 2.5” run size and smaller)*

Provide return bends for sprinkler connections, even with potable water connections. Deluge and dry sprinkler heads are excepted. Although NFPA 13 only requires return bends for water supplies connected to a raw water source, mill pond, or open top reservoir, experience with State Owned buildings has shown it to be less likely to gather sediment over time even with a potable water source, and taking the water from the top of the pipe allows greater flexibility for maintainability and flexibility with future renovations.

Flexible Sprinkler Piping. Flexible piping is allowed only if the product meets the following minimum requirements.

- ◆ *FM 1637 or UL 2443 listed flexible stainless steel hose with threaded end fittings.*
- ◆ *Composition: 100% Type 304 Stainless Steel.*
- ◆ *Fully welded non-mechanical fittings, braided shield, leak-tested with minimum 1 inch true-bore internal corrugated hose diameter*
- ◆ *Strict manufacturers’ installation instructions and limits shall be enforced. Flexible piping should be taken off from top of pipe, just like the hard-piped sprinkler heads and the requirements for return bends.*

21 13 16 Dry-Pipe Sprinkler Systems

Dry systems for freezers must have a regenerative compressed air dryer that will maintain the system dew point at least 200F below the lowest freezer operating temperature. For freezers with wet systems and dry pendant or dry sidewall heads, the connection between the sprinkler head and the wet pipe must extend at least 12 inches beyond the cooler and be provided with insulating wrap to prevent sweating.

Penetrations for sprinkler heads or sprinkler piping into special construction should be made by a manufacturer’s representative to preserve the warranty and functionality of the space.

Freeze Protection of Systems. Heat tracing is NOT acceptable for dry pipe or pre-action valve freeze protection. A heated room or closet must be provided.

Steel pipe used in dry pipe systems shall be limited to internally galvanized steel.

FIRE SUPPRESSION

Apply 30% area increase for dry pipe systems.

Low Air Pressure Alarm shall be connected to Fire Alarm Panel or it shall be provided with pressure alarm annunciation device installed at constantly attended location.

21 13 19 Pre-Action Systems

The fire detection system used for pre-action valve control must comply with the latest issue of “Fire Detection and Alarm Systems,” published by the NC Department of Insurance – Office of the State Fire Marshal/State Property Code Services Section. The required pre-action air pressures are: High Pressure Warning, 13-16psi
NOMINAL AIR PRESSURE SETTING, 7-10psi Low Pressure Warning, 2-4psi

21 13 39 Foam-Water Systems

Closed head foam-water systems shall be the pre-primed, wet pipe type, except use pre-action type if subject to freezing. (Dry pipe foam designs not permitted.) Design for solid performance at low flow rates. Endurance shall be at least 20 minutes full flow to the specified design area.

Foam concentrates from different manufacturers are not to be mixed. Replace the concentrate used during system inspections (“top off” tank). Ceiling sprinklers are to be 286oF (141oC) rating. Provide a two-inch flushing connection at the far end of each cross main, with a conveniently accessible valve and piping to a suitable discharge location that permits the observation and sampling of foam.

21-14

21 20 00 Fire-Extinguishing Systems

All alternative suppression systems must be installed per their referenced standards. The uses of alternative suppression systems do not remove the requirements for required sprinkler systems. When an alternative suppression system is installed in areas without a required sprinkler system, a 100% capacity reserve should be connected to the system with automatic discharge upon receipt of a second alarm in the protected area.

21 30 00 Fire-Pumps

Horizontal split case and vertical split case pumps are adversely affected by elbows or T’s mounted parallel to the plane of the pump. Such fittings are not permitted at the pump discharge, or within 10 pipe diameters of the suction side of the pump. There is no such restriction on elbows or T’s perpendicular to the plane of split case pumps, and they also do not apply to vertical in-line pumps

FIRE SUPPRESSION

(typically < 750gpm).

The water supply to the sprinkler system must provide at least 150% of pump rated capacity at a positive pressure and also meet the system demand at 20psi minimum.

An automatic pilot-operated throttling valve must be installed, (as allowed by NFPA20) on the output side of the booster pump, to maintain required minimum pressure. Suction side control is not permitted. Where permitted by the AHJ, a low pressure shutoff sensing the suction pressure may be substituted if the water supply provides 200% of pump rated capacity at a minimum pressure of 40psi, and an acceptable means is provided to periodically test the calibration of this device in its installed location. Where pump location makes flow testing from a header and play pipes impractical, provide a permanently installed meter for net pump performance testing without water streams. The meter outlet must discharge to a drain or to the suction tank, if provided, or (where permitted by the AHJ) to the suction side of the pump. A test header must still be provided for initial acceptance and other tests required by AHJ. Pump controller shall not be set to time-out pump run unless an automatic over-ride is provided to keep the pump running continuously in the event of water flow alarm.

ELECTRIC FIRE/BOOSTER PUMP POWER SOURCES

The power sources for electric fire or booster pumps shall comply with NFPA 20. It requires a reliable design that minimizes the chance of power loss during a fire event or other emergency, thereby assuring that pumps perform their vital function under adverse conditions.

- ◆ *A secondary source of electric fire pump power must be provided.*
- ◆ *The secondary power source must be separated from the normal power system and protected against interruption by fire attack, structural failure, operational accident, catastrophic failure of the main switchgear, etc.*
- ◆ *Any disconnecting means for the electric feed shall be clearly identified, lockable, identified for use as service equipment, and separated from other disconnecting means such that inadvertent contemporaneous operation is unlikely.*
- ◆ *Alternate arrangements to achieve power source reliability, such as feeds from two separate utilities (generally impractical), are subject to AHJ approval.*

FIRE PUMP ROOM DESIGN SHALL COMPLY WITH NFPA 20:

Indicate the size and location of any fire pumps required.

Indoor fire pump unit, in fully sprinklered building, shall be protected by min 1-hr rated enclosure, 2-hr in high rise.

Fire pump units located outdoors shall be located at least 50 ft away from any exposing building

Fire pump room shall comply with NFPA 20 regarding heating, ventilation and drainage. Temperature inside the fire pump room shall be maintained above 40F for protection against freezing and below 90F for protection against over-heating of control elements.

The Fire Pump Room shall be equipped with emergency lighting per NFPA 101. All electrical components and wiring shall meet the minimum requirements of the applicable NFPA 70

Per NFPA13 Chapter 8 Fire Department Connections (FDC) shall not be connected on the suction side of fire pumps.

The fire pump system shall be designed to withstand an earthquake forces as required in NFPA 20 and NC Building Code Chapter 16

Provide an equipment schedule on the plans that indicates the following capacities and characteristics:

- ◆ *Rated Capacity*
- ◆ *Total Rated Head*
- ◆ *Motor Horsepower*
- ◆ *Electrical Characteristics*
- ◆ *Volts*
- ◆ *Phase*
- ◆ *Hertz*
- ◆ *Full-Load Amperes*
- ◆ *Minimum Circuit Ampacity*
- ◆ *Maximum Overcurrent Protection*

FIRE SUPPRESSION**21 34 00 Pressure-Maintenance Pumps (Jockey Pumps)**

Indicate the size and location of any pressure-maintenance pumps required.

Provide an equipment schedule on the plans that indicates the following capacities and characteristics:

- ◆ *Rated Capacity*
- ◆ *Total Rated Head*
- ◆ *Motor Horsepower*
- ◆ *Electrical Characteristics*
- ◆ *Volts*
- ◆ *Phase*
- ◆ *Hertz*
- ◆ *Full-Load Amperes*
- ◆ *Minimum Circuit Ampacity*
- ◆ *Maximum Overcurrent Protection*

Plumbing

DIVISION 22

Contents

- 22-02 Codes And Standards
- 22-02 Basic Requirements
- 22-04 220523 General Duty Valves For Plumbing Piping
- 22-05 220529 Hangers And Supports For Plumbing Piping
- 22-06 220700 Plumbing Insulation
- 22-06 221100 Domestic Water Piping
- 22-07 221123 Domestic Pressure Booster System
- 22-09 221300 Soil, Waste, Vent, And Drain Piping
- 22-10 224000 Plumbing Fixtures And Equipment

22-01

List of Figures

- 22-13 *fig. 22a: Sample Plumbing Fixture Schedule
Indicating Acceptable Manufacturers*
- 22-15 *fig. 22b: Sample Piping Detail: Model RH-30*
- 22-16 *fig. 22c: Sample Piping Detail: Model RH-60*

PLUMBING

Codes And Standards

- ◆ *North Carolina Building Code*

Basic Requirements

Provide metering for each building. Meter shall communicate with the building automation system. Domestic hot water system shall communicate water flow along with inlet and outlet heater temperatures for use in energy calculations.

Provide reduced pressure zone backflow preventer on incoming water service line. Provide two BFP's in parallel to allow for testing.

Provide 4" thick isolation pads for all equipment.

Dielectric connections shall be used at any points within the piping systems where dissimilar metals meet. Careful attention shall be given to support brackets and hangers to select proper materials to avoid dissimilar metal contact at these points.

Comply with ANSI A13.1 for lettering size, length of color field, colors, and viewing angles of identification devices.

ENGRAVED PLASTIC-LAMINATE SIGNS

Provide engraving stock melamine plastic laminate, in the sizes and thickness indicated, engraved with engraver's standard letter style of the sizes and wording indicated, punched for mechanical fastening except where adhesive mounting is necessary because of substrate.

- ◆ *Thickness: 1/16" for units up to 20 square inches or 8" length; 1/8" for larger units.*
- ◆ *Fasteners: Self-tapping stainless steel screws.*

VALVE TAGS

Brass Tags: Provide 19-gauge polished brass tags with stamp-engraved piping or system abbreviation in 1/4" high letters and sequenced numbers 1/2" high and with 5/32" hole for fastener. Provide 1-1/2" diameter tags except as otherwise indicated.

Plastic Laminate Tags: Provide manufacturer's standard 3/32" thick engraved plastic laminate tags, with piping or duct system abbreviation in 1/4" high letters and sequenced numbers 1/2" high, and with 5/32" hole for fastener. Provide 1-1/2" square black tags with white lettering, except as otherwise indicated.

PLUMBING

WRAP-AROUND PLASTIC IDENTIFICATION

All plumbing piping identification shall adhere to ANSI A13.1 – 1981. Piping shall utilize pipe markers. All pipe markers shall be snap around whenever possible. Markers shall be located at each wall, floor or ceiling penetration, whether exterior or interior, and every 20 ft. thereafter. Markers shall be fully legible from floor level showing medium contained in pipe, and directional arrows.

Piping shall be identified as follows: DOMESTIC COLD WATER SUPPLY, DOMESTIC HOT WATER SUPPLY, ROOF DRAIN, MAKE UP WATER, WASTE, VENT & others by approval by submittals.

Piping in exposed areas, with canvas cloth jackets, to be painted with two coats of latex based paint suitable as per jacketing manufacturer's instructions, prior to piping identifications. Piping shall be labeled in accordance with WFU standards.

PIPING SYSTEM IDENTIFICATION

Locate identification as follows wherever piping is exposed to view in occupied spaces, machine rooms, accessible maintenance spaces and exterior non-concealed locations.

- ◆ *Near each valve and control device.*
- ◆ *Near each branch, excluding short take-offs for fixtures and terminal units; mark each pipe at branch, where there could be question of flow pattern.*
- ◆ *At locations where pipes pass through walls, floors, ceilings, or enter non-accessible enclosures.*
- ◆ *At major equipment items and other points of origination and termination.*
- ◆ *Spaced intermediately at maximum spacing of 50' along each piping run, except reduce spacing to 25' in congested areas of piping and equipment.*
- ◆ *On piping above removable acoustical ceilings, except omit intermediately spaced markers.*
- ◆ *Identify non potable piping and outlets.*

Valve Identification: Provide for valve tags on every valve cock and control device in each piping system. Exclude check valves, valves within factory-fabricated equipment units, plumbing fixture faucets, convenience and lawn-watering

PLUMBING

hose bibs, and shut-off valves at plumbing fixtures, and similar rough-in connections of end-use fixtures and units. List each tagged valve in a valve schedule for each piping system.

Plumbing Equipment Identification: Provide for engraved plastic laminate sign on or near each major item of mechanical equipment and each operational device. Provide signs for the following general categories of equipment and operational devices:

- ◆ *Main control and operating valves, including safety devices.*
- ◆ *Meters, gauges, thermometers and similar units.*
- ◆ *Pumps, compressors, and similar motor-driven units.*
- ◆ *Tanks and pressure vessels.*
- ◆ *VFD's and transmitters and Control Boxes.*
- ◆ *Other items as specified by Project Manager.*

220523 General Duty Valves For Plumbing Piping

Provide dielectric unions on the inlet and outlet connection to water heaters storage tanks and at all places where dissimilar metals join in piping and plumbing systems. Use dielectric unions as manufactured by Watts Regulator Inc., Zurn/Wilkins, Victaulic or equal.

Vacuum breaker shall be provided on each hose outlet. This includes hose bibbs, service sinks, wall hydrants, etc.

Air chambers shall be provided on the water supply to each plumbing fixture. Air chambers shall be one pipe size larger than the line in which they occur and shall extend vertically 18" up and cap. In lieu of air cushions, a system of pulsation absorbers may be submitted, provided the system is selected in accordance with PDI Standard W-201. Absorbers shall be by JOSAM, ZURN, SMITH or approved equal.

22-04

VALVES AND ACCESSORIES

Hose end gate valves, 3/4 - 2" shall be JENKINS NO. 372, CRANE 451, POWELL 503 or approved equal.

Wall hydrants shall be cast brass non-freeze, heavy duty with polished chrome face, brass operating parts, adjustment locknut, renewable nylon seat, 3/4" standard hose outlet, locking cover.

Ball valves shall be Cast Red Bronze with Two Piece Body, full port quarter turn. When installed in insulated piping furnish extended tee handle. All isolation valves above ceiling shall be ball valves.

PLUMBING

Pipes entering finished or occupied areas shall be provided with polished chrome plated escutcheon plates, held in place with set screws. Escutcheon plates shall be Grinnell Figure 20 or approved equal.

Backflow preventers shall be approved and listed by the Foundation For Cross-Connection Control & Hydraulic Research. Reduced pressure principle assemblies shall be provided on the domestic water and shall be tested, approved, and listed in accordance with FCCCHR Manual. Backflow preventers with intermediate atmospheric vent shall conform to ASSE 1012. Reduced pressure principle backflow preventers shall conform to ASSE 1013. Air gaps in plumbing systems shall conform to ASME A112.1.2. Backflow preventers shall be provided in parallel for testing.

220529 Hangers And Supports For Plumbing Piping

Pipe supports shall be provided for all piping. Pipe support components shall conform to accepted standards.

Hangers shall adequately support the piping system. On horizontal, hangers shall be located near or at changes in piping direction and concentrated loads. They shall provide vertical adjustment to maintain pitch required for proper drainage. They shall allow for expansion and contraction of the piping.

Horizontal lines of copper tubing shall be supported as below:

Nominal Tubing Size	Rod Diameter	Maximum Spacing
Up to 1 inch	3/8 inch	6 feet
1-1/4" and 1-1/2"	3/8 inch	8 feet
2 inches	3/8 inch	9 feet
2-1/2 inches	1/2 inch	9 feet
3 and 4 inches	1/2 inch	10 feet

Horizontal cast iron soil pipe shall be supported with one hanger for each pipe length and at fittings as required for proper support with hanger located close to hub or joint.

Vertical Piping: When support locations are not indicated on the drawings, cast iron pipe shall be supported at every floor and cast iron soil pipe, and copper pipe at every other floor or as required to prevent vibration.

220700 Plumbing Insulation

PIPE INSULATION

Materials shall be heavy density fiberglass with an all-service jacket composed of an out-er layer of vinyl, fiberglass scrim cloth, aluminum foil, and kraft paper, in that order, from outside to inside of pipe covering.

- ◆ *Above grade waste piping handling condensate drainage.*
- ◆ *Domestic cold water supply, hot water supply and return, and cold water make up lines.*
- ◆ *Roof drain leaders to the last vertical drop.*

Thicknesses:

- ◆ *Above grade waste piping: 1”.*
- ◆ *Domestic cold water supply, cold water make up lines, roof drain leaders - inside only - all pipe sizes: 1”.*
- ◆ *Domestic hot water supply and return: Pipe size 2-1/2” and larger - 1-1/2”, Pipe size 2” and smaller - 1”.*

Tanks and other equipment handling hot water (not factory insulated) shall be insulated with semi-rigid fiberglass board 1-1/2” thick. Cut to fit and cover with 8 oz. canvas jacket.

Roof drain bodies shall be insulated with insulating cement.

Insulation shall be installed per manufacturer’s instructions.

221100 Domestic Water Piping

All water piping shall be hard drawn copper tubing ASTM B 88 Type “L” above grade, Type “K” below grade. Fittings for copper tubing shall be ANSI B16.18 or B16.22 solder joint fittings. Ends of pipe shall be reamed, pipe and fittings cleaned. Use only 95-5 (95% tin and 5% antimony) solder with non-corrosive flux on 1-1/4” and smaller and on 1-1/2” and larger use silver solder (Minimum 12% Silver), with a melting point greater than 10000F.

Piping shall be installed so as to be free floating. 125 pound copper sweat pattern unions shall be provided in the piping as indicated on the drawings. Provide dielectric insulating unions where copper connects to ferrous piping. Use brass nipples or copper adapters at connections to fixtures.

Provide isolation valves for each individual riser and toilet group as required to service system.

PLUMBING

Sterilization of water piping shall be in accordance with AWWA Specification 0601. After the pressure tests have been made, the system shall be flushed with water. The chlorinating material shall be liquid chlorine-water mixture calcium hypochlorite, sodium hypo-chlorite, or chlorinated lime-water mixture. The solution shall have not less than 50 PPM available chlorine. The disinfecting solution shall be allowed to remain in the system for a minimum period of 24 hours. After disinfection, the system shall be flushed with clean water until residual chlorine content is not greater than .02 PPM. After the system is flushed, water samples shall be taken and tested at the Contractor's expense by an independent testing lab and reports shall be furnished to the engineer's for approval. If the water is found unsafe for human consumption, the disinfection procedure shall be repeated.

All water supply piping shall be testing before fixtures or faucets are connected by cap-ping or plugging the openings and applying a hydrostatic test pressure of 150 psig. Pressure shall hold constant (exception for temperature variation) for a period of 24 hours or as directed by the Engineer.

221123 Domestic Pressure Booster System

Obtain pumps from a single manufacturer.

Each booster package shall be hydrostatically and flow tested prior to shipment to verify system integrity.

The pump NPSH shall conform to the ANSI/HI 9.6.1-1998 standards for Centrifugal and Vertical Pumps for NPSH Margin.

Pump pressure ratings shall be at least equal to the system's maximum operating pressure at point where installed, but not less than specified.

Comply with ASME B31.9 for piping. Provide bypass and check valve around pumping system.

Electrical Components, Devices, and Accessories: Listed and labeled as defined in NFPA 70, by a qualified testing agency, and marked for intended location and application.

Provide on-site training session. Pump start-up shall be for the purpose of determining pump rotation, lubrication, voltage, and amperage readings. Start-up shall also include verification of proper electrical connections, pump's balance, and recording of discharge and suction gauge readings.

Basis of design: HYFAB division of the James M. Pleasants Company, MVP series booster.

General Description: Factory-assembled and tested variable speed domestic water pressure booster system with pumps, piping, isolation and check valves,

PLUMBING

controls, specialties and accessories mounted on a structural steel base. Pump and electrical protection shall be integrated into the pump controller package. The package shall be arranged in a compact design to allow it to be moved through a standard 36" doorway.

- ◆ *Pumps shall be close coupled, end suction, with volute housing mounted to allow "back pull out" service of the pump or motor without disturbing piping connections.*
- ◆ *Casing Construction: Radially split, ASTM A48 CL20 cast iron suitable for 175 PSI working pressure. The pump volute shall be supplied with vent and drain tapings. Connections shall be female NPT. The casing shall be O-ring sealed to the seal housing.*
- ◆ *Impeller Construction: Closed, single suction, fabricated from cast bronze conforming to ASTM B 584, keyed to shaft and secured by a locking cap-screw. Casing Wear Rings: Replaceable, bronze.*
- ◆ *Pump Shaft and Sleeve Bearings: Steel shaft, with a replaceable bronze shaft sleeve completely covering the wetted area of the shaft under the seal.*
- ◆ *Seals: Mechanical seals consisting of carbon rotating ring, stainless steel spring, ceramic seat, and flexible bellows and gasket.*
- ◆ *Provide check valves and isolation valves at each pump.*

Control Panel: Manufacturer shall provide a UL-508A listed complete electrical system including main disconnect, variable speed pump controller, pressure transducers, instrumentation and controls to automatically start, stop and modulate pump speed to smoothly, efficiently and reliably provide pump variable flow rates at a constant discharge pressure. The booster package shall include full pump, motor and drive safety features required to protect the equipment and piping system.

SEQUENCE OF OPERATION:

Whenever the pressure drops below the set system pressure, the lead pump shall start and run at speed required to maintain system pressure setpoint (as set by the operator.) If the pressure setpoint cannot be maintained by one pump, the lag pump shall start to provide the extra flow and pressure automatically.

When demand decreases to a level which can be met by one pump and an

PLUMBING

adjustable minimum run-timer has elapsed, the lag pump will be stopped.

The lead pump shall alternate based on elapsed run time. When the system experiences low demand the controller shall test for a no flow condition without the use of external switches or controls. The controller will stop the lead pump after verifying a zero demand condition exists and a minimum run-timer has elapsed.

221300 Soil, Waste, Vent, And Drain Piping

Soil, waste, vent and drain piping and drain piping and roof drain leaders shall be service weight ASTM A-74-69 bell and spigot, bearing the label of the Cast Iron Soil Pipe Institute and shall be listed by NSF International. The casings shall be gray iron of good quality made by Cupola, Air Furnace or Electric Furnace Process. The resultant pipe shall be compact, close grained metal, soft enough to permit cutting and drilling. Pipe shall have been hydrostatically tested at not less than 50 pounds per square inch gauge. Factory coated by heating to 300 degrees F. and dripping in a bath of coal tar pitch and oil.

Cleanout Plugs: Cleanouts shall be of the same size as the pipe except that cleanout plugs larger than 4" will not be required. Cleanouts shall consist of long sweep fittings to an easily accessible place.

Traps: Each fixture and piece of equipment including floor drains and hub drains, requiring connections to the drainage system shall be equipped with a trap placed as near to the fixture as possible. No fixtures shall be double trapped. Traps for floor drains and hub drains shall be deep seal "P" traps. All other traps shall be supplied under the "Fixture Paragraph".

Floor Flanges: Cast iron floor flanges shall be provided for connection of all floor outlet water closets. The joint between the closet trap and the floor flange shall be made tight with a red or black rubber fixture setting gasket.

Flashing: Vent pipes shall be flashed and made watertight as the roof with 4 pound sheet lead. Flashing shall extend not less than 8" from the vent pipes in all directions. Flashing shall be extended up the vent pipes and shall be turned down into the pipe. Minimum vent through the roof shall be 2" size.

Floor Drains: Floor drains shall be sized as indicated on the drawings. See plans for model number. Drains by Zurn, Josam, Jay R. Smith or equal will be acceptable.

Horizontal drain and waste piping with the building shall be given a grade of 1/8" per foot below ground and 1/8" per foot above ceilings unless otherwise indicated on the drawings. Piping 3" and smaller shall have minimum grade of 1/4" per foot. Main vertical soil and waste stacks shall be extended full size to

PLUMBING

the roof line and 12" above as vents, unless otherwise indicated on the drawings. Fittings shall be service weight when used on service weight pipe. Reduction of the size of drainage piping in the direction of flow is prohibited. Vent or tap tees will not be permitted on waste lines.

Joints between cast iron pipe and between cast iron pipe and fittings shall be made with neoprene push gaskets conforming to ASTM C-564. At Contractor's option joints above grade may be made with no-hub bands using heavy duty stainless steel clamps. Bands and clamps shall conform the requirement of ASTM Standard C – 1540 and shall be 304 stainless steel shielded couplings. Approved manufacturers: Husky HD2000, Clamp-All 80 or Mission Heavy Weight.

Cleanouts shall be installed where shown on the drawings but in no case shall they be more than 50 feet apart in piping 3" and under and 75 feet apart in piping 4" and larger.

All new soil, waste, drainage and vent piping shall be tested before fixtures are installed by capping or plugging the openings, except for the highest opening, and filling the entire system with water. If the system is tested in sections the minimum acceptable head shall be 10 ft. of water column. In testing successive sections, at least the upper 10 ft. of the preceding section shall be tested so that no joint or pipe within the building (except the uppermost 10 ft. of the system) shall have been submitted to a test of less than 10 ft. head of water. The water column shall be allowed to stand thus filled for a period of four hours.

224000 Plumbing Fixtures And Equipment

FIXTURES

Fixtures shall be as noted on sketch.

- ◆ *Water closets – Dual flush valves – 1.6/1.1 gallons per flush*
- ◆ *Urinals – 1/8 gallons per flush*
- ◆ *Lavatories (manual activation) – 0.5 gallons per minute flow rate*
- ◆ *Lavatories (metering) – 0.25 gallons per cycle*
- ◆ *Break room faucets – 0.5 gallons per minute flow rate*
- ◆ *Showers – 1.5 gallon per minute flow rate*

Refer to figure 22a for sample plumbing fixture schedule indicating acceptable manufacturers.

PLUMBING

WATER COOLER

Water coolers shall be as manufactured by Halsey Taylor. Provide at least one bottle fill station per floor. Standard cooler shall be model HRFSER-Q. Cooler with bottle fill shall be HTNB-HGRGR8BL-WF.

WATER HEATER

Water Heater shall be Spirax Sarco Rediheat RH-30 or RH-60 depending on the application. A single unit (or multiple units if the load justifies) shall be installed in all “non-critical” applications (administrative buildings, academic buildings, etc.). In dorms and food service applications, a redundant unit shall be provided (in addition to the quantity required to meet the load) for manual changeover when the primary units are off line.

The building automation system shall monitor entering and leaving temperature and re-circulation pump status. Temperature gauges shall be provided in addition to the sensors.

Refer to figures 22b and 22c for sample piping details.

HOT WATER STORAGE TANK

Tank shall be of glass-lined design. 4” handhole shall have a working pressure of 150 psi. Controls shall include: high temperature limit control, dual thermostats. The tank shall be insulated with vermin-proof glass fiber insulation or equal. Tank must meet ASHRAE 90A-2007 for thermal efficiency and standby loss. The outer jacket shall have a baked enamel finish over a bonderized undercoating. All internal surfaces of the heaters exposed to water shall be glass-lined and have a nickelous oxide undercoating. The glass lining shall be fused to the steel by firing at a temperature range of 1400 degrees F. to 1600 degrees F. Heaters tank shall have a 3 year limited warranty against corrosion and tank failure due to sediment build-up as outlined in the written warranty.

Stainless steel tanks may be considered if project budget allows. Tank shall be constructed of laser welded 316 stainless steel and shall be insulated as noted above.

A pressure and temperature relief valve shall be furnished and installed.

Units with a storage capacity of 120 gallons or more shall be constructed and stamped pursuant to the ASME Code, Section IV, or Section VIII, Division 1, as applicable.

PLUMBING

CAULKING

Fixtures, fittings and accessories shall be caulked at floor and wall perimeter and behind flanges and fittings in a fashion that the wall openings are sealed, but no sealant is ex-posed. Caulking shall be silicone rubber. Install all caulking per manufacturer's instructions.

DESCRIPTION	BASIC FIXTURE	TRIM & ACCESSORIES
WATER CLOSET WALL MTD.	AMERICAN STANDARD AFWALL #3555.128 VITREOUS CHINA ELONGATED RIM, WALL MOUNTED TOILET WITH DUAL FLUSH SIPHON JET FLUSHING. 1.6/1.1 GPM, 1 1/2" TOP STUD INLET.	FLUSH VALVE: SLOAN /VES111-1.6/1.1 DUAL FLUSH. P.C. TO VERIFY HEIGHT OF FLUSH VALVE. SEAT: CHURCH #135TT SOLID PLASTIC OPEN FRONT SEAT.
WATER CLOSET ADA COMPLIANT WALL MTD.	AMERICAN STANDARD AFWALL #3555.128 VITREOUS CHINA ELONGATED RIM, WALL MOUNTED TOILET WITH DUAL FLUSH SIPHON JET FLUSHING. 1.6/1.1 GPM, 1 1/2" TOP STUD INLET.	FLUSH VALVE: SLOAN /VES 111-1.6/1.1 DUAL FLUSH. P.C. TO VERIFY HEIGHT OF FLUSH VALVE. SEAT: CHURCH #135TT SOLID PLASTIC OPEN FRONT SEAT.
WATER CLOSET FLOOR MTD.	AMERICAN STANDARD #2234.D15 VITREOUS CHINA ELONGATED RIM, FLOOR MOUNTED TOILET WITH DUAL FLUSH SIPHON JET FLUSHING. 1.6/1.1 GPM, 1 1/2" TOP STUD INLET.	FLUSH VALVE: SLOAN /VES 111-1.6/1.1 DUAL FLUSH. P.C. TO VERIFY HEIGHT OF FLUSH VALVE. SEAT: CHURCH #135TT SOLID PLASTIC OPEN FRONT SEAT.
WATER CLOSET ADA COMPLIANT FLOOR MTD.	AMERICAN STANDARD #3043.102 VITREOUS CHINA ELONGATED RIM, FLOOR MOUNTED TOILET WITH DUAL FLUSH SIPHON JET FLUSHING. 1.6/1.1 GPM, 1 1/2" TOP STUD INLET.	FLUSH VALVE: SLOAN /VES 111-1.6/1.1 DUAL FLUSH. P.C. TO VERIFY HEIGHT OF FLUSH VALVE. SEAT: CHURCH #135TT SOLID PLASTIC OPEN FRONT SEAT.
WALL HUNG LAVATORY ADA COMPLIANT	AMERICAN STANDARD #0355.D12 WHITE VITREOUS CHINA WALL HUNG LAVATORY	FAUCET: DELTA MODEL #500-WF. 4" CENTERS, VANDAL RESISTANT LOW FLOW AERATOR, CERAMIC CARTRIDGE, ALL CHROME PLATED. SUPPLIES: MCGUIRE #171LK CHROME PLATED SUPPLY KIT 1/2" NOM x 3X8"OD 12" FLEXIBLE RISER.

fig. 22a: SAMPLE PLUMBING FIXTURE SCHEDULE INDICATING ACCEPTABLE MANUFACTURERS

		<p><u>DRAIN:</u> MCGUIRE #155-A CHROME PLATED LAV GRID DRAIN 1 1/2" TAILPIECE. PROVIDE W/TRAP PRIMER CONNECTION WHERE NEEDED.</p> <p><u>INSULATION KIT:</u> 102-EZ TRUEBRO SUPPLY & TRAP INSULATION KIT.</p>
<p>OVAL COUNTER TOP LAVATORY ADA COMPLIANT</p>	<p>SEE ARCHITECTURAL DRAWINGS</p>	<p><u>FAUCET:</u> DELTA MODEL #500-WF. 4" CENTERS, VANDAL RESISTANT LOW FLOW AERATOR, CERAMIC CARTRIDGE, ALL CHROME PLATED.</p> <p><u>SUPPLIES:</u> MCGUIRE #171LK CHROME PLATED SUPPLY KIT 1/2" NOM x 3X8"OD 12" FLEXIBLE RISER.</p> <p><u>DRAIN:</u> MCGUIRE #155-A CHROME PLATED LAV GRID DRAIN 1 1/2" TAILPIECE. PROVIDE W/TRAP PRIMER CONNECTION WHERE NEEDED.</p> <p><u>INSULATION KIT:</u> 102-EZ TRUEBRO SUPPLY & TRAP INSULATION KIT.</p>
<p>SHOWER</p>	<p>SEE ARCHITECTURAL DRAWINGS</p>	<p><u>SHOWER VALVE:</u> ZURN #27301-SS-MT-S9</p> <p><u>SHOWER DRAIN:</u> 2-INCH BRASS DRAIN BY CLARION.</p>
<p>SHOWER, ADA</p>	<p>SEE ARCHITECTURAL DRAWINGS</p>	<p><u>SHOWER VALVE:</u> ZURN TEMP-GARD #27300-SS-MT-HW-H9</p> <p><u>SHOWER DRAIN:</u> 2-INCH BRASS DRAIN BY CLARION.</p>

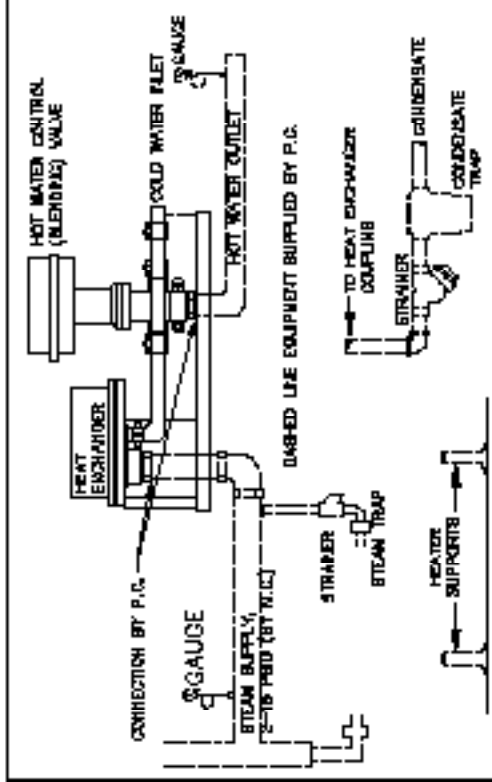

DOMESTIC STEAM TO WATER WATER HEATER DETAIL (DHW-1)

NTS (TYPICAL FOR DHW-2 & DHW-3)

SPIRAX-SARCO MODEL SELECTION:
DHW-1, 2, & 3; MODEL RH-30

PACKAGE TO INCLUDE:

- (1) ES000645 RECIRCULATION SYSTEM TEMPERATURE ELEMENT (120F)
- (1) ES000681 FACTORY ASSEMBLY OF RECIRC SYSTEM
- (1) ES000600 RH-30 W/CAST IRON SHELL AND COPPER TUBES - BASE UNITY
- (1) ES000677 FACTORY ASSEMBLY OF RH-30 TRAP AND STRAINER KIT INCLUDES 24" ANGLE IRON STAND
- (1) ES000640 RH-30/60 RECIRCULATION SYSTEM W/O TEMPERATURE ELEMENT
- (1) ES000673 RH-30 TRAP AND STRAINER (LOOSE)
- (1) ES000670 2" REDHEAT H PACKAGE INCLUDES 25P PRESSURE REGULATOR, PRESSURE PILOT, AND STRAINER (OPTIONAL)

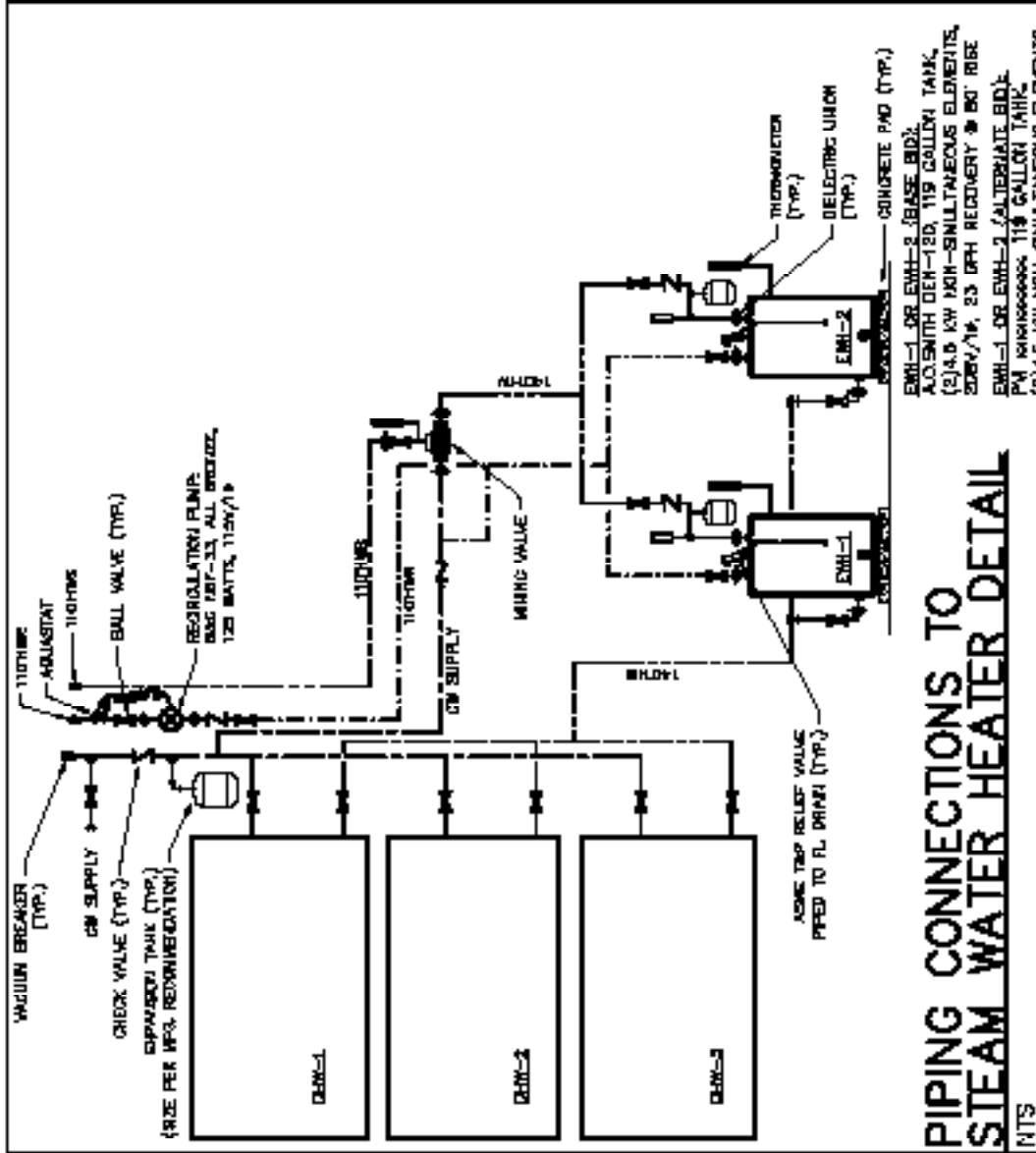

PIPING CONNECTIONS TO STEAM WATER HEATER DETAIL

NTS

EWH-1 OR EWH-2 (BASE BID)
A.C. SMITH DEN-120, 119 GALLON TANK,
(2) 4.0 KW NON-SIMULTANEOUS ELEMENTS,
200V/1ϕ, 23 CFH RECOVERY @ 80' RISE
EWH-1 OR EWH-2 (ALTERNATE BID)
P.A. INTERNATIONAL 119 GALLON TANK,
(2) 4.5 KW NON-SIMULTANEOUS ELEMENTS,
200V/1ϕ, 23 CFH RECOVERY @ 80' RISE

Project	WPU STANDARD	Drawn	
Client Name	WATER HEATER DETAILS	Scale	AS SHOWN
	RH-30 (2)		XXXX
			XXXX

fig. 22b: SAMPLE PIPING DETAIL: MODEL RH-30

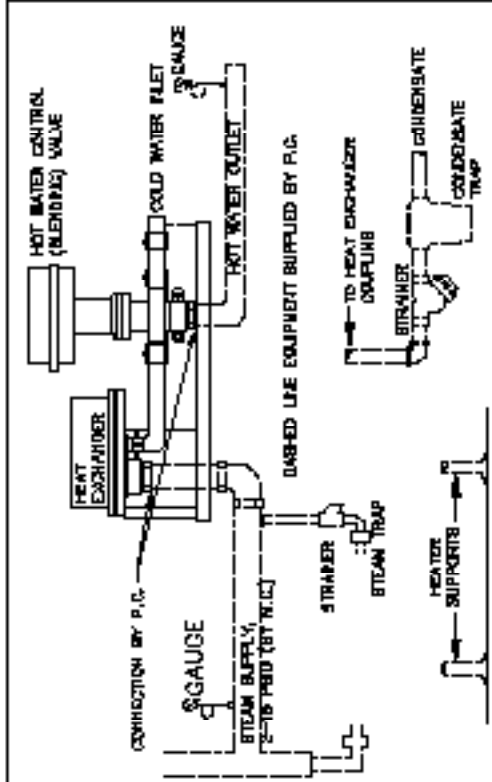

DOMESTIC STEAM TO WATER WATER HEATER DETAIL (DHW-1)

NTS (TYPICAL FOR DHW-2 & DHW-3)
 SPIRAX-SARCO MODEL SELECTION:
 DHW-1, 2, & 3: MODEL RH-60
 PACKAGE TO INCLUDE:

- (1) ES000645 RECIRCULATION SYSTEM TEMPERATURE ELEMENT (120F)
- (1) ES000661 FACTORY ASSEMBLY OF RECIRC SYSTEM
- (1) ES000601 RH-60 W/CAST IRON SHELL AND COPPER TUBES - BASE UNITY
- (1) ES000678 FACTORY ASSEMBLY OF RH-60 TRAP AND STRAINER KIT INCLUDES 24" ANGLE IRON STAND
- (1) ES000640 RH-30/60 RECIRCULATION SYSTEM W/O TEMPERATURE ELEMENT
- (1) ES000674 RH-60 TRAP AND STRAINER (LOOSE)
- (1) ES000670 2" REDHEAT H PACKAGE INCLUDES 25P PRESSURE REGULATOR, PRESSURE PILOT, AND STRAINER (OPTIONAL)

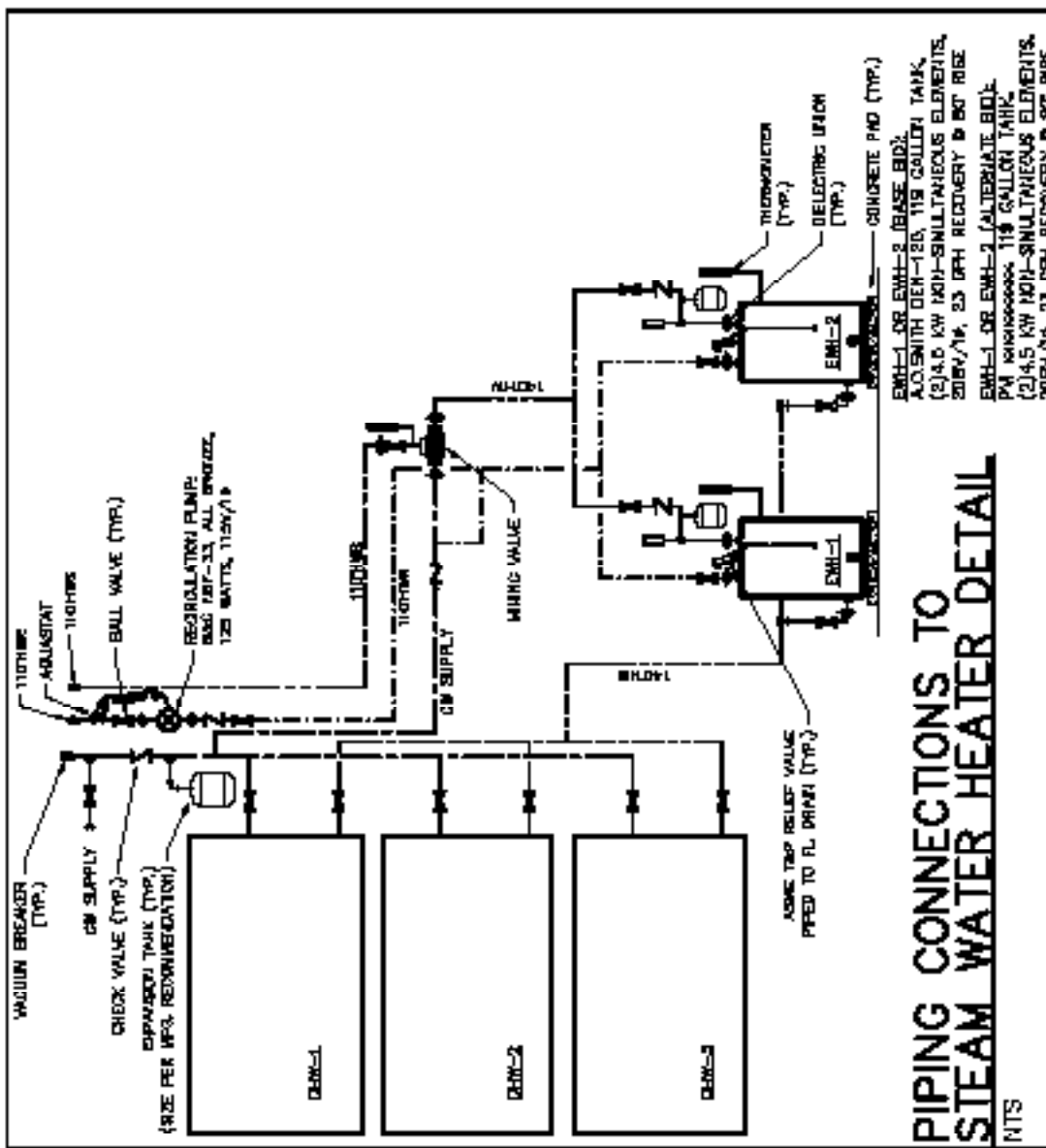

PIPING CONNECTIONS TO STEAM WATER HEATER DETAIL

NTS

Project	WPU STANDARD WATER HEATER DETAILS	Drawn By	
Sheet Name	RH-60 SH	Scale	XXXXXX
			XXXX

fig. 22c: SAMPLE PIPING DETAIL; MODEL RH-60

Heating, Ventilation & Air Conditioning

DIVISION 23

Contents

- 23-02 Codes and Standards
- 23-02 Base System
- 23-05 Basic Requirements
- 23-09 230514 Variable Frequency Drives
- 23-09 230519 Meters and Gages for HVAC Piping
- 23-11 230523 General Duty Valves for HVAC Piping
- 23-12 230529 Hangers and Supports for HVAC Piping & Equipment
- 23-13 230593 Testing, Adjusting, and Balancing
- 23-14 230700 Insulation
- 23-16 230900 Building Automation System
- 23-28 230950 Facility Monitoring System
- 23-29 232113 Hydronic Piping
- 23-30 232123 Hydronic Pumps
- 23-31 232213 Steam and Condensate Heating Piping
- 23-32 232500 Water Treatment
- 23-32 233000 Air Duct Accessories
- 23-33 233113 Metal Ducts
- 23-35 233113 Fabric Air Dispersion System
- 23-36 233400 HVAC Fans
- 23-36 233600 Air Terminal Units
- 23-38 235700 Heat Exchangers for HVAC
- 23-38 237200 Make-Up Air Unit
- 23-38 237313 Modular Indoor Central Station Air Handling Units

Codes and Standards

- ◆ *North Carolina State Building Code*
- ◆ *ASHRAE 90.1 (Energy Standard)*
- ◆ *ASHRAE 62.1 (Ventilation Standard)*
- ◆ *ASHRAE 55 (Thermal Comfort Standard)*
- ◆ *ASHRAE Handbook Series*
- ◆ *SMACNA (Ductwork Standard)*

Base System

ADMINISTRATIVE/ACADEMIC BUILDING

The building will be heated and cooled through an overhead air duct system with air being supplied by multiple variable volume air handling units.

Individual space control will be provided through single inlet terminal units with hot water coils on the unit discharge. At a minimum, all densely occupied spaces (classrooms, for example) will have individual terminal units. Office and support spaces will have one terminal unit per work station. Terminal units for each individual office will be considered as budget allows.

A dedicated outdoor air makeup unit will supply ventilation air to the air handling units through a ducted system. The unit will reclaim energy from the building relief air and toilet exhaust by transferring energy from the exhausted air to the ventilation air through a rotating enthalpy wheel integral to the makeup unit. The unit will vary the volume of ventilation air to the space in response to a facility management system (as manufactured by Aircuity). Sensors will be located throughout the structure in all densely occupied spaces. Installation of a chilled water coil and reheat wheel in the outdoor air makeup unit for additional dehumidification will be considered relative to outdoor air volume requirements.

Chilled water will be provided to the building from the campus loop and distributed to the various air handling units through an overhead piping system. Two tertiary pumps for the building chilled water loop will be provided. Pumps will be piped in parallel.

Hot water will be provided to the building through a steam to water heat exchanger. Steam will be supplied from the campus distribution system. Water will be distributed to the air handling units through an overhead piping system. Two system pumps, piped in parallel, for the distribution system will be provided.

HEATING, VENTILATION & AIR CONDITIONING

RESIDENCE HALL

Individual space control will be provided multiple fan coil units or small air handling units hot water coils on the unit discharge.

A dedicated outdoor air makeup unit will supply ventilation air to occupied areas through a ducted system. The unit will reclaim energy from the building relief air and toilet exhaust by transferring energy from the exhausted air to the ventilation air through a rotating enthalpy wheel integral to the makeup unit. The unit will vary the volume of ventilation air to the space in response to carbon dioxide sensors located throughout the structure. Installation of a chilled water coil and reheat coil for additional dehumidification should be considered relative to outdoor air volume requirements.

Chilled water will be provided to the building from the campus loop and distributed to the various air handling units through an overhead piping system. Two tertiary pumps for the building chilled water loop will be provided. Pumps will be piped in parallel.

Hot water will be provided to the building through a steam to water heat exchanger. Steam will be supplied from the campus distribution system. Water will be distributed to the air handling units through an overhead piping system. Two system pumps, piped in parallel, for the distribution system will be provided.

CONTROLS

The building automation system will provide control and/or monitoring for the buildings chilled and hot water pumping systems, pumps, air handling units, energy recovery units, terminal units, fan coil units exhaust fans, ventilation fans, outside air dampers, demand control ventilation schedule, occupancy schedules, gas meters, electric meters, steam meter, and water meter.

The building automation system will comply with minimum current campus standards and shall be provided and installed by one of the following companies:

- ◆ *Alerton*
- ◆ *Johnson Controls*
- ◆ *Schneider Electric/TAC*

Partial list of operational energy saving features to be included as part of the base system controls is as follows:

- ◆ *Hot water temperature reset based on outdoor air ambient conditions.*
- ◆ *De-coupler valve and piping on the incoming chilled water loop (to allow the campus chilled water plant pumps to provide the motive force for water flow during moderate cooling load times.*
- ◆ *Variable speed pumping systems provided for both the chilled water and hot water distribution systems to minimize pumping energy at low load.*
- ◆ *Space temperature set point reset based on space occupancy. for example, if a classroom is unoccupied (even during occupied hours), space temperature shall be adjusted up or down from set point. Temperature adjustment range to be relative to global building occupancy schedule.*
- ◆ *Enthalpy based economizer cycle on all air handling units to allow for use of outside air instead of return air whenever energy content of outside air is lower.*
- ◆ *Reset discharge air temperature of variable volume air handling units based on outdoor air conditions/load requirements of zone furthest from cooling set point. (In this mode, system will constantly monitor return air humidity and return system to “normal” mode of operation upon exceeding set point.)*
- ◆ *Monitor space carbon dioxide levels to reduce outside air volume (and thus load on the energy plant) from maximum required by code prescriptions to minimum required by code whenever building occupancy allows. Monitoring system shall be by Aircuity.*

OPTIONAL SYSTEMS

The following systems will be considered in place or in addition to the base system described above. All systems considered outside the base system shall be proven to be economically viable to the University over the life of the equipment. System operation and maintainability for the building shall be reviewed and discussed with the University and proven to be equivalent or better than the base system as well.

- ◆ *Chilled beams for individual space conditioning. Four pipe beams will be considered for most areas. In spaces with*

HEATING, VENTILATION & AIR CONDITIONING

higher heat loss, supplemental heating will be provided.

- ◆ *Displacement ventilation for conditioning of large areas (i.e. classrooms).*
- ◆ *Capture and piping of HVAC condensate to chiller plant to provide for cooling tower makeup.*

Basic Requirements

DESIGN CONDITIONS

Outside Air Conditions

Winter Design Conditions	18.9°F DB
Summer Design Conditions	90.6°F DB, 73.0°F WB

Indoor Air Conditions

Winter Design Conditions	70°F DB
Summer Design Conditions	75°F DB, 50% RH

Drives shall be V-belt and shall be selected to overcome the starting inertia of the equipment without slippage, but in no case shall be less than 150% of the full motor load. Drives 1/2 HP and smaller may be provided with single belts. Drives 3/4 HP and larger shall be provided with the number of belts necessary to transmit the required power with 95% minimum efficiency.

Motors larger than 5 HP shall be provided with variable frequency drives. All three phase motors may be provide with drives. All single phase motors shall be ECM type.

for pumps, compressors, and other rotating machinery install concrete pads minimum 4 inches thick or as shown. All pads shall be extended six (6) inches beyond machine base in all directions with top edge hampered. Insert six (6) inch long, 1/2" round steel dowel rods at 12" on center into floors to anchor pads.

Sound level readings shall not exceed NC levels as recommended in Table 1, Chapter 48 of 2011 ASHRAE Applications Handbook.

Mechanical equipment over one horsepower shall be isolated from the structure with resilient vibration and noise isolators supplied by one manufacturer to the Mechanical Contractor. Where isolator type and required deflection are not shown, equipment shall be isolated in accordance with the 2011 ASHRAE Applications Handbook, Chapter 48, Table 47.

Flexible duct connections shall be provided at inlet and outlet of all fans or

cabinets containing fans and shall be constructed such as to allow a minimum movement of 2 inches in any direction and will not restrict normal movement of any equipment.

Dielectric connections shall be used at any points within the piping systems where dissimilar metals meet. Careful attention shall be given to support brackets and hangers to select proper materials to avoid dissimilar metal contact at these points.

Individual motor controllers complete with auxiliary contacts, control transformers, push buttons, selector switches and remote push button stations not specifically specified to be furnished with the equipment shall be provided under this section. Motor controllers shall comply with NEMA Standards and be complete with proper size heaters and auxiliary contacts and shall be in NEMA enclosures as required. Unless otherwise noted, push button stations shall be oil-tight heavy duty type. Controllers shall be manual, magnetic, or combination type with disconnect switch or circuit breaker as indicated on the drawings or where required by the NEC. Controllers shall include motor over current protection in each phase conductor. Each motor controller shall be provided with phenolic nameplate, black with 1/4" high letters and white border, indicating equipment served, attached using counter sunk screws.

Where piping penetrates fire rated floors or walls, penetrations shall be sealed with a U.L. approved fire stopping system. System shall be as manufactured and detailed by 3M Company or approved equal.

Escutcheon plates shall be provided for all exposed pipes and all exposed conduit passing through walls, floors and ceilings. Plates shall be nickel plated, of the split ring type, of size to match the pipe or conduit.

LABELS, TAGS, COLOR CODING AND INSTRUCTIONS

Comply with ANSI A13.1 for lettering size, length of color field, colors, and viewing angles of identification devices.

Stencils: Standard fiberboard stencils, prepared for required applications with letter sizes generally complying with recommendations of ANSI A13.1 for piping and similar applications shall be used. Stencils shall not be less than 1-1/4" high letters for ductwork and not less than 3/4" high letters for access door signs and similar operational instructions. Stencil paint shall be standard exterior type stenciling enamel; black, except as otherwise indicated; either brushing grade or pressurized spray-can form and grade.

HEATING, VENTILATION & AIR CONDITIONING

ENGRAVED PLASTIC-LAMINATE SIGNS

Provide engraving stock melamine plastic laminate, in the sizes and thickness indicated, engraved with engraver's standard letter style of the sizes and wording indicated, punched for mechanical fastening except where adhesive mounting is necessary because of substrate.

Thickness: 1/16" for units up to 20 square inches or 8" length; 1/8" for larger units.

Fasteners: Self-tapping stainless steel screws.

VALVE AND DAMPER TAGS

Brass Tags: Provide 19-gauge polished brass tags with stamp-engraved piping or duct system abbreviation in 1/4" high letters and sequenced numbers 1/2" high and with 5/32" hole for fastener. Provide 1-1/2" diameter tags except as otherwise indicated.

Plastic Laminate Tags: Provide manufacturer's standard 3/32" thick engraved plastic laminate tags, with piping or duct system abbreviation in 1/4" high letters and sequenced numbers 1/2" high, and with 5/32" hole for fastener. Provide 1-1/2" square black tags with white lettering, except as otherwise indicated.

WRAP-AROUND PLASTIC IDENTIFICATION

All plumbing/mechanical piping identification shall adhere to ANSI A13.1 – 1981. Pip-ing shall utilize pipe markers. All pipe markers shall be snap around whenever possible. Markers shall be located at each wall, floor or ceiling penetration, whether exterior or interior, and every 20 ft. thereafter. Markers shall be fully legible from floor level showing medium contained in pipe, and directional arrows.

Piping shall be identified as follows: HEATING WATER SUPPLY, HEATING WATER RETURN, CHILLED WATER SUPPLY, CHILLED WATER RETURN, HIGH PRESSURE STEAM, LOW PRESSURE STEAM, CONDENSATE RETURN, CONDENSATE PUMP DISCHARGE, MAKE UP WATER, & others by approval by submittals.

Piping in exposed areas, with canvas cloth jackets, to be painted with two coats of la-tex based paint suitable as per jacketing manufacturer's instructions, prior to piping identifications. Piping shall be labeled in accordance with WFU standards.

DUCTWORK IDENTIFICATION

General: Provide for identification of air supply, return, exhaust, intake, and relief ductwork with stenciled signs and arrows, showing ductwork service and

direction of flow, in black and white.

Locations: Ductwork shall be identified every 20' in spaces with removable ceilings and at each access door in spaces with hard ceilings. Exposed ductwork shall be identified every 20' in mechanical rooms. As described above, ductwork shall be labeled on both sides of floor and wall penetrations.

Access Doors: Provide engraved plastic-laminate signs on each access door in ductwork and housings, indicating purpose of access (to what equipment) and other maintenance and operating instructions, and appropriate and procedural information.

PIPING SYSTEM IDENTIFICATION

Locate identification as follows wherever piping is exposed to view in occupied spaces, machine rooms, accessible maintenance spaces and exterior non-concealed locations.

- ◆ *Near each valve and control device.*
- ◆ *Near each branch, excluding short take-offs for fixtures and terminal units; mark each pipe at branch, where there could be question of flow pattern.*
- ◆ *At locations where pipes pass through walls, floors, ceilings, or enter non-accessible enclosures.*
- ◆ *At access doors, manholes and similar access points which permit view of concealed piping.*
- ◆ *At major equipment items and other points of origination and termination.*
- ◆ *Spaced intermediately at maximum spacing of 50' along each piping run, except re-duce spacing to 25' in congested areas of piping and equipment.*
- ◆ *On piping above removable acoustical ceilings, except omit intermediately spaced markers.*

Valve Identification: Provide for valve tags on every valve cock and control device in each piping system. Exclude check valves, valves within factory-fabricated equipment units, plumbing fixture faucets, convenience and lawn-watering hose bibs, and shut-off valves at plumbing fixtures, HVAC terminal devices and similar rough-in connections of end-use fixtures and units. List each tagged valve in a valve schedule for each piping system.

Damper Identification: Provide for tags on every damper used as a control

HEATING, VENTILATION & AIR CONDITIONING

device. Exclude HVAC terminal devices. List each tagged damper in a schedule for each duct system.

Mechanical Equipment Identification: Provide for engraved plastic laminate sign on or near each major item of mechanical equipment and each operational device.

230514 Variable Frequency Drives

Furnish complete variable frequency drives with integral bypass. Drives shall be ABB ACS550 unless otherwise coordinated with WFU. Drives by Cutler Hammer, Allen Bradley and Yaskawa may be considered.

The manufacturer shall provide start-up commissioning of the variable frequency drive and its optional circuits by a factory certified service technician who is experienced in start-up and repair services.

The VFD shall be warranted by the manufacturer for a period of 36 months from date of shipment. The warranty shall include parts, labor, travel costs and living expenses incurred by the manufacturer to provide factory authorized on-site service.

The motor(s) and winding(s) which are directly connected to the VFD shall be warranted by the VFD manufacturer against breakdown which is directly attributed to the VFD.

230519 Meters and Gages for HVAC Piping

Provide thermometers and pressure gauges for all entering and leaving conditions on all major heat transfer equipment. This shall include, but not be limited to air handling unit coils, heat exchangers, chilled water connection to campus loops. Small terminal unit coils, fan coils, etc. shall be provided with Pete's Plugs or equivalent.

BIMETALLIC-ACTUATED THERMOMETERS

- ◆ *Standard: ASME B40.200.*
- ◆ *Case: Liquid-filled type(s); stainless steel with 3-inch nominal diameter.*
- ◆ *Dial: Nonreflective aluminum with permanently etched scale markings and scales in deg F.*
- ◆ *Connector Type(s): Union joint, adjustable angle, with unified-inch screw threads.*
- ◆ *Connector Size: 1/2 inch, with ASME B1.1 screw threads.*
- ◆ *Stem: 0.25 or 0.375 inch in diameter; stainless steel.*

- ◆ *Window: Plain glass.*
- ◆ *Ring: Stainless steel.*
- ◆ *Element: Bimetal coil.*
- ◆ *Pointer: Dark-colored metal.*
- ◆ *Accuracy: Plus or minus 1 percent of scale range.*

DUCT-THERMOMETER MOUNTING BRACKETS

Description: Flanged bracket with screw holes, for attachment to air duct and made to hold thermometer stem.

PRESSURE GAGES

- ◆ *Direct-Mounted, Metal-Case, Dial-Type Pressure Gages:*
- ◆ *Standard: ASME B40.100.*
- ◆ *Case: Liquid-filled type(s); cast aluminum or drawn steel; 4-1/2-inch nominal diameter.*
- ◆ *Pressure-Element Assembly: Bourdon tube unless otherwise indicated.*
- ◆ *Match pressure connection size in first subparagraph below with gage attachment size.*
- ◆ *Pressure Connection: Brass, with NPS 1/4 or NPS 1/2, ASME B1.20.1 pipe threads and bottom-outlet type unless back-outlet type is indicated.*
- ◆ *Movement: Mechanical, with link to pressure element and connection to pointer.*
- ◆ *Dial: Nonreflective aluminum with permanently etched scale markings graduated in psi.*
- ◆ *Pointer: Dark-colored metal.*
- ◆ *Window: Plastic.*
- ◆ *Ring: Metal.*
- ◆ *Accuracy: Grade D, plus or minus 5 percent of whole scale range.*

FLOWMETERS

Turbine Flowmeters – ONICON F1110 flowmeter with sensor and indicator. Sensor and indicator shall cover operating range of equipment or system served. Sensor shall be an impeller turbine for inserting into pipe fitting or for installing

HEATING, VENTILATION & AIR CONDITIONING

in piping and measuring flow directly in gallons per minute (liters per second). Construction shall be bronze or stainless-steel body, with plastic turbine or impeller.

- ◆ *Minimum Pressure Rating: 150 psig.*
- ◆ *Minimum Temperature Rating: 180 deg F.*
- ◆ *Accuracy: Plus or minus 1/2 percent.*
- ◆ *Steam – Veris Accelabar differential pressure flow meter.*
- ◆ *PRESSURE-GAGE SCALE-RANGE SCHEDULE*
- ◆ *Scale Range for Chilled-Water Piping: 0 to 100 psi.*
- ◆ *Scale Range for Heating, Hot-Water Piping: 0 to 100 psi.*
- ◆ *TEMPERATURE-GAGE SCALE-RANGE SCHEDULE*
- ◆ *Scale Range for Chilled-Water Piping: 0 to 100 deg F.*
- ◆ *Scale Rand for Heating, Hot-Water Piping: 40 to 250 deg F.*

230523 General Duty Valves for HVAC Piping

APPROVED MANUFACTURERS

Spring check valves shall be installed on water lines 2-1/2 inches and above. Valves shall be non-slam type of such design that closing is controlled by spring action so de-signed to return disc or leaves to seat at zero velocity or before reversal of flow. Disc or leaves shall be free-flowing with no greasing or counterweights required. Body shall be semi-steel, 125 psi rated. Disc or leaves and seat shall be bronze with stainless steel spring.

Butterfly valves shall be lug type and suitable for water service. Valves shall have EPDM seats suitable for temperature up to 275 degrees Fahrenheit and pressure up to 150 psig. Body shall be cast iron, disc shall be aluminum bronze, and shafts shall be stainless steel. Valves 2” to 6” shall be interim positive lock, lever operators. Valves 8” and larger shall have encased gear operators with hand wheel. Bodies shall be lug type.

Ball valves shall be full port bronze, two piece construction rated for 125 SWP/400 WOG. Valves shall have conventional port with Teflon seats. Stem shall be of silicon bronze. Sizes 1/4”-2”.

Flow balance valves, shall be Bell and Gossett Circuit Setter, or approved equal.

Water Pressure Reducing Valve: Furnish and install in the heating and cooling system water pressure reducing valves as shown with a bypass line around the valve and fittings. Pressure reducing valve shall be installed at each fill connection to the HVAC system. Reducing valve shall be of bronze body construction with

Buna-N- Nylon diaphragms, and stainless renewable seats.

Strainers for water service with end suction pumps shall be bolted top basket type with 40-mesh monel screen. for other water service where space is insufficient for basket strainers, and for steam service strainers shall be Y-type with 40-mesh monel screen. Strainers shall have blow-down tappings, removable baskets and be iron bodied with flanged ends.

Backflow preventers, reduced pressure (RPZ) backflow preventers shall be installed at each connection between any HVAC system and the domestic water supply system. Preventers shall be of bronze body construction with stainless steel internal parts and flange bolts. Assembly shall be furnished with unions at inlet and outlet to facilitate servicing. Unit shall be rated for a working pressure of 150 psi and a working temperature of 210 degrees Fahrenheit and be tested and certified in accordance with the American Society of Sanitary Engineering Standard 1013-1071.

Relief valves shall be ASME pressure relief valve set to 15 psi above maximum normal system operating pressure. The discharge from valves on water lines shall be piped to the nearest floor drain; valves on steam lines shall be piped to the outside.

A pressurization and air elimination system to accommodate the expanded water generated by the increase in temperature in a water heating or chilled water system and to control the increase in pressure at all critical components in the system to the maximum allowable for those components shall be provided.

The diaphragm-type expansion tank shall be welded steel, constructed tested and stamped in accordance with Section VIII of the ASME Code for a working pressure of 125 psi and shall be supported by steel legs or a base for vertical installation or steel saddles for horizontal installations.

The air separator shall be a Spirotherm Spirovent air/dirt separator.

230529 Hangers and Supports for HVAC Piping & Equipment

METAL PIPE HANGERS AND SUPPORTS

Carbon-Steel Pipe Hangers and Supports:

- ◆ *Description: MSS SP-58, Types 1 through 58, factory-fabricated components.*
- ◆ *Galvanized Metallic Coatings: Pregalvanized or hot dipped.*
- ◆ *Nonmetallic Coatings: Plastic coating, jacket, or liner.*
- ◆ *Padded Hangers: Hanger with fiberglass or other pipe*

HEATING, VENTILATION & AIR CONDITIONING

insulation pad or cushion to support bearing surface of piping.

- ◆ *Hanger Rods: Continuous-thread rod, nuts, and washer made of carbon steel.*
- ◆ *Metal Pipe-Hanger Installation: Comply with MSS SP-69 and MSS SP-89. Install hangers, supports, clamps, and attachments as required to properly support piping from the building structure.*

230593 Testing, Adjusting, and Balancing

Work shall be performed by an independent balancing company certified by AABC or NEBB. Technicians shall be competent in the trade of testing and balancing environmental systems and shall be done in an organized manner utilizing appropriate test and balance forms.

The test and balance contractor shall be a sub-contractor to the HVAC contractor.

The test and balance report shall be submitted prior to the final inspection. The TAB sub-contractor shall attend the final to spot check air and water flows.

Performance readings shall be taken and recorded on all air and water distribution devices and the system shall be balanced out prior to acceptance. Balancing of the system shall be accomplished with duct dampers and only minor adjustments made with grille dampers. Record and submit results in table form alongside of scheduled quantities.

All controls shall be calibrated by qualified personnel prior to acceptance date. Thermo-stats shall be in close calibration with one another and shall operate their respective units without interference from adjacent units.

SPECIAL REQUIREMENTS

Variable Air Volume Duct Pressure Setpoint. TAB contractor shall determine the optimum duct pressure setpoint as follows: Determine and record in the TAB report, the hydraulically most remote terminal and lock its damper in fully open position. Set all other terminals downstream of control duct pressure transmitter to maximum volume setpoint. Adjust fan speed manually until most remote terminal volume equals its maximum volume setpoint. Record the corresponding sensed static pressure at the duct pressure sensor location as the optimum duct pressure setpoint. If necessary to provide diversity, terminals that are not downstream of the duct pressure transmitter may be closed.

Variable Volume Pumping System Differential Pressure Setpoint: TAB contractor shall determine the optimum differential pressure setpoint as follows:

Determine and record in the TAB report, the hydraulically most remote coil. Lock its control valve in fully open position and open the balancing valve. Set all other coils downstream of control differential pressure transmitter to balanced flow with control valve in wide open position. Adjust variable volume pump speed manually until most remote coil flow equals its design value. Record the corresponding sensed differential pressure at the differential pressure sensor location as the optimum differential pressure setpoint. If necessary to provide diversity, coil control valves that are not downstream of the duct pressure transmitter may be closed.

Variable Volume Pumping System Pump Balancing: After optimum differential pressure setting has been determined as described above, open all coil control valves and balance coil flows to 120% of specified values while pump speed is under automatic control maintaining the optimum setpoint. Record pump data, including pump speed, under these conditions. Turn variable volume pump off. Start constant volume pump. Throttle pump discharge valve until control differential pressure falls to the recorded optimum setpoint. Record constant volume pump data. Do not throttle pump discharge valve on variable volume pumps. Leave discharge valve on variable volume pumps wide open.

Calibrate controls flow meters for chilled water and steam.

Provide TAB result to ATC contractor for use in control logic.

230700 Insulation

PIPE INSULATION

Heavy density fiberglass.

- ◆ *Hot water piping*

Closed cellular rubber (non-absorbant).

- ◆ *Chilled water supply and return piping
and condensate drain piping*

Asbestos-free calcium silicate.

- ◆ *Steam supply and condensate return piping.*

All piping systems to be insulated followed by a kraft paper, all service jacket composed of an outer layer of vinyl, fiberglass scrim cloth, aluminum foil, and kraft paper, in that order, from outside to inside of pipe covering

All exposed piping, such as mechanical rooms, stairwells, crawl spaces, attics or other occupied spaces, shall have an additional layer of Kraft paper all service jacket with vapor sealing tape followed by an 8 oz./sq. yd. canvas cloth wrap,

HEATING, VENTILATION & AIR CONDITIONING

glued with two coats of sizing. Finish by painting with two coats of latex based paint.

THICKNESSES

Hot water heating supply and return piping.

- ◆ Pipe sizes 1 ½" and under – 1 ½" thick, 3# density
- ◆ Pipe sizes 2" to 4" – 2" thick, 3# density
- ◆ Pipe sizes larger than 4", 2 ½" thick, 3# density

Chilled water piping

- ◆ Pipe sizes 1 ½" and under - 1" thick, closed cellular rubber
- ◆ Pipe sizes 2" to 4" – 2" thick, closed cellular glass
- ◆ Pipe sizes larger than 4", 2 ½" thick, closed cellular glass

Steam piping

- ◆ Pipe sizes 1" and under - 1" thick calcium silicate
- ◆ Pipe sizes 1 ¼" to 3" - 2" thick calcium silicate
- ◆ Pipe sizes larger than 3" - 3" thick calcium silicate

Steam condensate return piping

- ◆ All pipe sizes - 1" thick calcium silicate

Equipment handling chilled water. Insulate with closed cell polystyrene blocks cut to fit and finished with 8 oz. canvas jacket. Pump insulation shall be removable to allow servicing of pump.

Tanks and other equipment handling hot water (not factory insulated). Insulate with semi-rigid fiberglass board 1 ½" thick. Cut to fit and cover with 8 oz. canvas jacket.

Metal or PVC jackets may be provided in lieu of canvas jackets.

DUCT INSULATION

Materials

Insulation shall be Owens-Corning as specified hereinafter or products of Cer-tain-Teed/St. Gobain, Armstrong or Manville. Adhesives shall be as manufactured by 3-M Foster or insulation manufacturer. Insulation shall have composite (insulation, jacket and adhesive) fire and smoke hazard rating as tested by ASTM E-84, not exceeding Flame Spread -25 and Smoke Developed -50.

LINED DUCT

When necessary for sound reduction, ductwork shall be lined with Owens-Corning Aeroflex Vapor-Seal Duct Insulation, 1-1/2 pcf, 1" thick, or equal by Certain-Teed/St. Gobain or Johns Mansville. Use of liner shall be discussed and confirmed with WFU.

WRAPPED DUCT

Ducts shall be insulated by wrapping with fiberglass with vapor barrier jacket with joints overlapped a minimum of two inches. Insulation shall be adhered to duct with non-combustible insulation bonding adhesive applied in 4" strips, 8" on center. All joints shall be secured with flare door staples on 3" centers through all laps over duct tape.

Supply – 2" thick, 1.5# density

DUCTWORK IN MECHANICAL ROOMS

Ductwork in mechanical penthouses below shall be externally insulated with rigid fiber-glass insulation, thicknesses as noted:

- ◆ *Supply – 2" thick, 1.5# density*
- ◆ *Return, Relief and Outside Air – 1.5" thick, 1# density*

All ductwork exposed to view (equipment rooms, etc.) shall be covered with an 8 oz. canvas jacket or an embossed aluminum jacket.

230900 Building Automation System

Building automation system shall be by Alerton, JCI or Schneider. System shall be the current version of each manufactures offering and shall be coordinated with WFU. Furnish a totally native BACnet-based system, including a Microsoft compatible operator's workstation. The operator's workstation, all building controllers, application controllers, and all input/output devices shall communicate using the protocols and network standards as defined by ANSI/ASHRAE Standard 135-2001, BACnet. All workstations and controllers, including unitary controllers, shall be native BACnet devices. No gateways shall be used for communication to controllers installed under this section. Gateways may be used for communication to existing systems or to systems installed under other sections. Sample sequences are as follows:

HEATING, VENTILATION & AIR CONDITIONING

CHILLED WATER SYSTEM - SEQUENCE OF OPERATION

A unit mounted controller (capable of standalone operation) will control the chilled water system.

General: This system consists of two CHW pumps that pulls chilled water from the campus loop.

CHW System Enable: Primary chilled water system will be enabled when any chilled water valve opens to more than 75% and when campus loop pumps are energized. Once enabled, the chilled water system will remain enabled for a minimum of one hour.

The chilled water system will disable when all the chilled water valves close to less than 10% continuously or, whenever the campus loop pumps are de-energized.

Chilled Water Pumps: The pumps will run in a lead/lag fashion where the lead pump assignment will be reassigned based on the lowest runtime when both pumps are on and when both pumps are off. The lead pump will be enabled and run continuously when the chilled water system is enabled and will be stopped when the chilled water system disable.

If the lead pump is commanded to run and status is not proven, an alarm will generate, and the lag pump will energize.

Chilled Water Pump Speed: Once the pump is enabled, the VFD speed will be a minimum of 30% (adj.). When pump status is proven, the pump VFD speed will modulate to maintain the remote loop differential pressure (RDP) setpoint.

The (RDP) setpoint will reset between minimum (5 psi, adj.) and maximum (13 psi, adj.) limits to maintain the “worst case” (most open) AHU chilled water valve. The setpoint will reset once every 5 min. (adj.) by an increment of 0.5 psi (adj.) as follows:

- ◆ *The pressure setpoint will reset up when the most open valve command is above 95%.*
- ◆ *The pressure setpoint will remain the same when the most open valve command is between 90 and 95%.*
- ◆ *The pressure setpoint will reset down when the most open valve command is below 90%.*

Upon communication failure between the BAS controller and the differential pressure sensor, the setpoint will be the maximum limit.

HOT WATER SYSTEM - SEQUENCE OF OPERATION

A unit mounted controller (capable of standalone operation) will control the hot water system.

General: This system consists of one heat exchanger and two loop pumps.

HW System Enable: Primary hot water system will be enabled when the outside air temperature falls below 55°F (adj.) for 15 min. (adj.) or, when any hot water valve opens to more than 50% continuously for 15 min. (adj.) or, whenever it is manually enabled by the operator from the operator workstation.

The hot water system will be disabled when the outside air temperature rises above 57°F (adj.) for 15 min. (adj.) or, when all the hot water valves close to less than 10% continuously for 30 min. (adj.) or, whenever it is manually disabled by the operator from the operator workstation.

Hot Water Pumps: The pumps will run in a lead/lag fashion where the lead pump assignment will be reassigned based on the lowest runtime when both pumps are on and when both pumps are off. The lead pump will be enabled and run continuously when the hot water system is enabled and will be stopped when the hot water system disable.

If the lead pump is commanded to run and status is not proven, an alarm will generate, and the lag pump will energize.

Hot Water Pump Speed: Once the pump is enabled, the VFD speed will be a minimum of 30% (adj.). When pump status is proven, the pump VFD speed will modulate to maintain the remote loop differential pressure (RDP) setpoint.

The (RDP) setpoint will reset between minimum (5 psi, adj.) and maximum (13 psig, adj.) limits to maintain the “worst case” (most open) AHU preheat valve and VAV valve. The setpoint will reset once every 5 min. (adj.) by an increment of 0.5 psi (adj.) as follows:

- ◆ *The pressure setpoint will reset up when the most open valve command is above 95%.*
- ◆ *The pressure setpoint will remain the same when the most open valve command is between 90 and 95%.*
- ◆ *The pressure setpoint will reset down when the most open valve command is below 90%.*

Upon communication failure between the BAS controller and the differential pressure sensor, the setpoint will be the maximum limit.

Hot Water Supply Temperature Setpoint: Once pump status is proven, the 1/3, 2/3's steam valves will modulate in sequence to maintain the hot water supply setpoint. The setpoint will reset based on outside air temperature. As outside air

HEATING, VENTILATION & AIR CONDITIONING

temperature rises from 10°F. (adj.) to 50°F. (adj.), the HW supply setpoint will decrease from 180°F. (adj.) to 120°F. (adj.).

VAV AIR HANDLING UNIT - SEQUENCE OF OPERATION

A programmable controller capable of stand-alone operation will control the units. The VAV air handlers will be started and stopped based on requests from associated VAV zones.

General: Each air handling unit will have a variable frequency drive on the supply fan, economizer cooling capability, a chilled water coil for cooling, and a hot water coil in the preheat position for heating. Reheat, as required for space temperature control, will be accomplished at the terminal units.

Fan Control (General): The supply fan will be controlled through a panel integral with the respective variable frequency drive (VFD). When the respective VFD control panel switch is in the “remote/auto” position, the supply fan will be started and stopped and fan speed will be controlled through the BAS. When the respective switch is in the “keypad/hand” position, the fan will run and the fan speed may be controlled through a manual speed adjustment integral to the VFD control panel. When the starting circuit is activated by the BAS or by placing the selector switch in “keypad/hand” position, the VFD will start unloaded and will ramp up to speed as programmed into the VFD’s safety circuit.

Unoccupied Mode: The supply fan will be indexed off and will remain off until the start of night high limit, night low limit, warm-up, cool-down, or occupied mode. The return air damper will remain open and the outside air and relief dampers will remain closed.

Night Low Limit Mode (NLL): On a request for night low limit operation from minimum number of VAV zones (adj.) the supply fan VFD and supply air temperature control will be enabled. During NLL mode the supply air temperature setpoint will be set to the warm-up supply air temperature setpoint (70°F., adj.). When the number of VAV zones requesting NLL drops below the minimum required or occupied mode becomes active, NLL will be disabled.

Night High Limit Mode (NHL): On a request for night high limit operation from a minimum number of VAV zones (adj.) the supply fan VFD and supply air temperature control will be enabled. If outside enthalpy conditions are favorable the economizer control will enable. When the number of VAV zones requesting NHL drops below the minimum required or occupied mode becomes active, NHL will be disabled.

Warm-up Mode: On a request for warm-up operation from a minimum number of VAV zones (adj.), the supply fan VFD and supply air temperature

control will be enabled. During warm-up mode, the supply air temperature setpoint will be set to the warm-up supply air temperature setpoint (75°F, adj.). When the occupied mode becomes active warm-up mode will be disabled and the unit will begin occupied mode control.

Cool-down Mode: On a request for cool-down operation from a minimum number of VAV zones (adj.), the supply fan VFD will enable and the supply air temperature setpoint will be 55°F. (adj.). When occupied mode becomes active, the cool-down control loop will be disabled and the unit will begin occupied mode control.

Afterhours Mode: On a request for afterhours operation from any VAV zone, the supply fan VFD and supply air temperature control will be enabled. All other VAV's associated with that AU, will be enabled in occupied mode. When the override timer expires or occupied mode becomes active, afterhours mode will be disabled.

Occupied Mode: On a request for occupied mode operation from a minimum number of VAV zones (adj.), the AHU supply fan will enable.

Supply Fan Speed Modulation: The supply fan speed will modulate as required to maintain the duct static pressure setpoint (1.5" W.C. adj.). Once enabled, the minimum supply fan speed signal will be 20% (adj.). In manual mode, the static pressure setpoint will remain at the startup/manual setpoint. In automatic mode, the static pressure setpoint will be reset between 0.5" W.C. (adj.) and 2.0" W.C. (adj.) to maintain pressure requests of the VAV boxes at 4 (adj.). (See VAV sequence for pressure request generation). If the number of VAV box pressure requests is above setpoint, the duct static pressure setpoint will reset towards the high limit. The setpoint will reset once every 5 min. (adj.) by 0.1" W.C. (adj.) until the number of VAV box pressure requests reaches setpoint.

The supply air temperature setpoint will reset between 55°F. (adj.) and 65°F. (adj.) to maintain cooling requests of the VAV boxes at 4 (adj.). (See VAV sequence for cooling request generation). If the number of VAV box cooling requests is above setpoint, the supply temperature setpoint will reset towards the lower limit. The setpoint will reset once every 5 min. (adj.) by 0.3°F. (adj.) until the number of VAV box cooling requests reaches setpoint.

The supply air temperature setpoint will reset between 55°F. (adj.) and 65°F. (adj.) to maintain the return air humidity at a maximum of 65% (adj.).

During Unoccupied Period, if the AHU is energized for heating or warm-up, the chilled water valve will remain closed.

HEATING, VENTILATION & AIR CONDITIONING

Preheat Control: When the supply fan is on, the preheat valve will modulate at the higher of the following signals:

- ◆ *A signal will modulate to maintain a discharge temperature at a setpoint that is 5°F. (adj.) below the current AHU discharge temperature setpoint.*
- ◆ *A signal will modulate to maintain a low limit of 45°F. (adj.) leaving the coil.*
- ◆ *A signal that modulates to maintain a discharge air temperature 75°F. (adj.) during NHL and warm-up mode.*

When the supply fan is off, the preheat valve will modulate to maintain a mixed air temperature setpoint of 45°F. (adj.).

Minimum Outside Air: During occupied mode, the mixing dampers will open to a minimum position as required to maintain return air CO₂ setpoint.

Economizer Control: When outside air enthalpy falls below return air enthalpy (with 2 btu/lb cycle differential), economizer control will enable. Economizer mode will be disabled any time outside air enthalpy rises above return air enthalpy. When economizer mode is enabled, the outside air, return air, and relief dampers will modulate to maintain the mixed air temperature setpoint. The mixed air temperature setpoint will be 3°F. (adj.) less than the current supply air temperature setpoint. As the economizer signal increased from 0 to 100%, the OA and RA dampers will open 0 to 90% (adj.) to the outside air. This will ensure flow through the return air duct at all times so that the return air sensors are sensing accurate conditions. As the mixed air temperature drops from 55°F. To 45°F, the economizer control signal will be restricted from 100% to 0% open to the outside air.

The OA and RA dampers will be control based on the higher of the “minimum OA” and “economizer” signals.

Space Pressure Control: The economizer dampers (OA, RA, and relief) will normally modulate together via the same signal. However, the position of the relief damper will be overridden via a slow acting signal to prevent the building static pressure from exceeding +0.05” W.C. (adj.). During occupied mode only, the position of the relief damper will be the higher of the output from the mixing damper signal and the building static pressure signal.

General Alarms: Software alarms will be generated and displayed at the operator's workstation as follows:

- 23.1 Equipment Status: A level 2 alarm will generate when the AHU supply fan is commanded to run and status is not proven for 15 sec. after the command is initiated. A message will appear as follows:
- 23.1.1 AHU Failure: Status is indicated on AHU's fan even though it has been commanded to stop. Check the HOA switch, control relay, status sensing device, contactors, etc. involved in starting the unit. Acknowledge this alarm when the problem has been corrected.

System Condition Alarms: Software alarms will be generated and displayed at the operator's workstation as follows:

- 23.2 Supply Temperature: A level 2 alarm will generate when any supply temperature sensor is above or below its setpoint +/-8°F. (adj.) for 15 min. continuously. A message will appear as follows:
- 23.2.1 AHU sensor: sensor is indicating that the discharge temperature is outside of acceptable limits.
- 23.3 Heating Coil Discharge Temperature: A level 2 alarm will generate when any heating coil discharge temperature sensor is below its setpoint minus 8°F. (adj.) for 15 min. continuously. A message will appear as follows:

Diagnostic Alarms: Software alarms will be generated and displayed at the operator's workstation as follows:

- 23.4 Runtime: A level 5 alarm will generate if the runtime of the equipment exceeds setpoint. A message will appear as follows:
- 23.5 Heating Valve Leak: A level 3 and 4 alarm will generate if the heating valve is closed and the temperature rise across the heating coil exceeds 2°F continuously for 30 minutes, or if the supply temperature is more than 5° above setpoint for more than 30 min. continuously. A message will appear as follows:
- 23.5.1 AHU Energy Waste: An unexpected temperature rise is occurring across the heating coil. Please check for leaking valve or faulty controls.

HEATING, VENTILATION & AIR CONDITIONING

- 23.6 Cooling Valve Leak: A level 3 and 4 alarm will generate if the cooling valve is closed and the temperature drop across the cooling coil exceeds 2°F continuously for 30 minutes, or if the supply temperature is more than 5°F below setpoint for more than 30 min. continuously. A message will appear as follows:
- 23.6.1 AHU Energy Waste: An unexpected temperature drop is occurring across the cooling coil. Please check for leaking valve or faulty controls.
- 23.7 Cooling Capacity Shortage: A level 3 and 4 alarm will generate if the cooling valve is open above 99% continuously for 1 hour.
- 23.7.1 AHU Lack Of Capacity: The cooling valve has been commanded to the full open position for an extended time period. Ensure that the setpoint for the control loop is at a reasonable value and that flow to the coil has not been obstructed as in a plugged strainer, throttled balancing valve, debris in the control valve, etc.

Safeties: The following safeties will be monitored and will be displayed at the operator's workstation:

- 23.8 Fire Alarm/Smoke Detector: A level 2 alarm will generate on a signal from any smoke detector associated with the unit, the supply and return fans will be de-energized via the FACP relay module (hard-wired interlock). A message will appear as follows:
- 23.8.1 AHU-X Fire Alarm: AHU fire alarm/smoke detector is in an alarm condition.
- 23.9 Freezestat: The low temperature switch (freezestat) installed in the mixed air stream will shut down the supply and relief fans (hardwired interlock) and return all dampers and valves to their normal positions whenever the mixed air temperature falls below setpoint (38°F, manually adjustable and reset). A level 2 alarm will generate and a message will appear as follows:
- 23.9.1 AHU Freezestat: AHU freezestat is in an alarm condition.

- 23.10 High Pressure Switch: A high pressure switch will be installed in the discharge supply and relief ductwork to shutdown the supply and relief fans (hardwire interlock) when the supply or relief duct pressure exceeds 4.0”W.C. (manually adjustable and reset). A level 2 alarm will generate and a message will appear as follows:
- 23.10.1 AHU High Pressure: AHU high pressure switch is in an alarm condition.
- 23.11 Freeze Protection: A level 2 alarm will generate on a drop in mixed air temperature below 25°F (adj.). The unit will shutdown and a message will appear as follows:
- 23.11.1 AHU Freeze Protection: AHU’s mixed air temperature reached freezing conditions. Please check that the outside air damper is closing properly.

Unit Shutdown Hardware Positions: When the AHU is commanded off, the CHW valve will be commanded to its normal position (“closed to the coil”), the HW valve will control as in the preheat sequence. Dampers will be commanded to their normal positions (return air damper “open” to return air, outside air damper “closed” to outside air, and relief air damper “closed” to outside air.)

ENERGY RECOVERY UNIT - SEQUENCE OF OPERATION

A programmable controller capable of stand-alone operation will control the units. The unit will be started and stopped based on requests from associated air handling units to maintain minimum outdoor air.

General: Each unit will have a variable frequency drive on the supply fan and exhaust/relief fan

Fan Control (General): The supply and relief fans will be controlled through a panel integral with the respective variable frequency drive (VFD). When the respective VFD control panel switch is in the “remote/auto” position, the supply fan will be started and stopped and fan speed will be controlled through the BAS. When the respective switch is in the “keypad/hand” position, the fan will run and the fan speed may be controlled through a manual speed adjustment integral to the VFD control panel. When the starting circuit is activated by the BAS or by placing the selector switch in “keypad/hand” position, the VFD will start unloaded and will ramp up to speed as programmed into the VFD’s safety circuit.

Unoccupied Mode: The supply fan and exhaust fans will be indexed off and will remain off until the start of occupied mode.

HEATING, VENTILATION & AIR CONDITIONING

Afterhours Mode: On a request for afterhour's operation from any VAV zone, the supply and relief fan VFD will be enabled.

Occupied Mode: On a request for occupied mode operation the ERV supply and relief/exhaust fans will enable. The relief damper shall modulate to maintain building pressurization.

SUPPLY FAN SPEED MODULATION: The supply fan speed will modulate as required to maintain the duct static pressure setpoint (1.5" W.C. adj.). Once enabled, the minimum supply fan speed signal will be 20% (adj.). In manual mode, the static pressure setpoint will remain at the startup/manual setpoint. In automatic mode, the static pressure setpoint will be reset between 0.5" W.C. (adj.) and 2.0" W.C. (adj.) to maintain pressure requests of the air handling unit outside air dampers. The duct static pressure setpoint will reset towards the high limit. The setpoint will reset once every 5 min. (adj.) by 0.1" W.C. (adj.) until the number of VAV box pressure requests reaches setpoint.

23.12 The energy recovery wheel will rotate whenever the supply fan is in operation. Wheel rotation failure during occupied mode will generate an alarm to the building automation system.

Exhaust Fan Speed Modulation: The exhaust fan speed will modulate as required to maintain airflow relation to supply as determined by air volume measured by the supply, relief and exhaust air flow monitoring stations. The exhaust air monitoring station shall modulate its associated damper to maintain constant air volume. The relief air monitoring station shall modulate its associated damper to maintain building pressurization relative to supply airflow.

Economizer Control: When air handling units are operating in economizer control and minimum outside air (as determined by CO₂) can be maintained, the unit supply fan will be off, the relief air damper shall close and the relief fan will operate as required to maintain exhaust air flow. The energy recovery wheel will operate in the mode.

General Alarms: Software alarms will be generated and displayed at the operator's workstation as follows:

23.13 **Equipment Status:** A level 2 alarm will generate when the supply or relief fan is commanded to run and status is not proven for 15 sec.

After the command is initiated a message will appear as follows:

23.13.1 **ERU Fan Failure:** Status is indicated on fan even though it has

been commanded to stop. Check the HOA switch, control relay, status sensing device, contactors, etc. involved in starting the unit. Acknowledge this alarm when the problem has been corrected.

System Condition Alarms: Software alarms will be generated and displayed at the operator's workstation as follows:

- 23.14 A level 2 alarm will generate when wheel rotation is not detected for 15 min. continuously. A message will appear as follows:
- 23.14.1 ERU Wheel Rotation: Sensor is indicating that the unit energy recovery wheel is not operating.

VAV BOX w/HW HEAT - SEQUENCE OF OPERATION

A unit mounted VAV controller (capable of standalone operation) will control each unit. The VAV will be started via pre-determined optimum start through the Building Automation System (BAS). The unit will be de-energized in accordance with time schedules through the BAS.

Unoccupied Mode: The desired airflow will be zero cfm and will remain zero cfm until the start of night high limit, night low limit, warm-up, cool-down, or occupied mode.

Night Low Limit Mode (NLL): On a drop in space temperature below the night low limit setpoint (NLL, 55°F adj.) a NLL request will be sent to the associated AHU (see AHU sequence). When primary airflow is detected, space temperature heating control will be enabled. When the space temperature increases above the NLL setpoint and the NHL/NLL minimum runtime has expired (2 hrs, adj.); or the occupied schedule becomes active, NLL will be disabled.

Night High Limit Mode (NHL): On a rise in space temperature above the night high limit setpoint (NHL, 85°F adj.), a NHL request will be sent to the associated AHU (see AHU sequence). When primary airflow is detected, space temperature cooling control will be enabled. When the space temperature decreases below the NHL setpoint, and the NHL/NLL minimum runtime has expired (2 hrs, adj.); or the occupied schedule becomes active, NHL will be disabled.

Warm-Up Mode: An optimum start algorithm will determine how early the VAV needs to enable to satisfy the occupied heating setpoint before the scheduled occupied mode begins. In warm-up mode, a warm-up request will be sent to the associated AHU (see AHU sequence). When primary airflow is detected, space temperature heating control will be enabled. When the occupied schedule

HEATING, VENTILATION & AIR CONDITIONING

becomes active warm-up mode will be disabled and the unit will begin occupied mode control.

Cool-down Mode: An optimum start algorithm will determine how early the VAV needs to enable to satisfy the occupied cooling setpoint before the scheduled occupied mode begins. In cool-down mode, a cool-down request will be sent to the associated AHU (see AHU sequence). When primary airflow is detected, space temperature heating control will be enabled. When the occupied schedule becomes active cool-down mode will be disabled and the unit will begin occupied mode control.

Afterhours Mode: On a call for after-hours operation, by pressing the right up button of the wall mounted space temperature sensor, an afterhours request is sent to the associated AHU (see AHU sequence). When primary airflow is detected the VAV will control as in occupied mode. If one VAV is in afterhours mode, all other VAV's associated with the same AHU will enter occupied mode. The VAV will stay in afterhours override until the override timer expires or until the start of an occupied cycle; whichever occurs first. The override time (2 hrs.) can be adjusted at the wall mounted space temperature or the operator's workstation.

Occupied Mode: An occupied request will be sent to the associated AHU (see AHU sequence). The desired airflow will increase from zero cfm to the minimum airflow setpoint.

Space Temperature Control: Heating and cooling signals will be generated based on the deviation of the space temperature heating and cooling setpoints. The desired airflow will reset based on these signals.

Heating: On a drop in space temperature below the current heating setpoint (70°F, adj.), the unit will enter heating mode. As the heating signal increases from 25 to 100% (adj.), the desired airflow will reset linearly from the minimum to the reheat airflow setpoint. The hot water valve will also modulate based on the heating signal. As the heating signal increases from 0 to 75% (adj.), the valve will modulate from 0-100%.

A "heating request" is sent to the associated AHU (see VAV AHU sequence) whenever the heating signal is 100% or the space temperature is 2°F (adj.) below the current heating setpoint.

If warm primary airflow is detected from the associated AHU, the desired airflow will reset linearly from the minimum to the maximum airflow setpoint as the heating signal increases.

Cooling: On a rise in space temperature above the current space temperature cooling setpoint (74°F, adj.), the unit will enter cooling mode. As the cooling

signal increases the desired airflow will reset linearly from the minimum to the maximum airflow setpoint.

A “cooling request” is sent to the associated AHU (see VAV AHU sequence) whenever the cooling signal is 100% or the space temperature is 2°F (adj.) above the current cooling setpoint.

Damper Control: When primary airflow is detected the damper will modulate to maintain the current desired airflow. To prevent excessive damper movement, the damper will not modulate if the actual airflow is within +/-3% of the desired airflow.

A “pressure request” is sent to the associated AHU (see VAV AHU sequence) whenever the damper signal increases above 95% (with a 5% deadband).

If no primary airflow is detected, indicating the associated AHU is not operational; the damper will open to 50%. This will prevent over pressurization of the duct upon AHU startup.

Alarms: The following software alarms will be generated and displayed at the operator’s workstation:

- ◆ *Space too warm (3°F greater than cooling setpoint)*
- ◆ *Space too cold (3°F less than heating setpoint)*
- ◆ *Bad space temp sensor alarm (greater than 120°F or less than 40°F).*

Occupancy Sensor Interlock: If sensor indicates space is unoccupied, damper position may go to fully closed if space temperature is satisfied.

LUCID BUILDING DASHBOARD KIOSK

Provide for each building. Building Dashboard shall enable occupants, visitors and the public to view energy and water use information on touchscreen displays. Comparative graphs and visualizations shall indicate the performance of building.

230950 Facility Monitoring System

The Air Sampling Network of the FMS shall consist of networked based distributed Air Sampling Controllers for routing of discreet air and data packets from the designated test areas/locations back to the Multi-Sensor Monitor; or individual home runs of Air Sampling Tubing from the designated test areas/locations back to the Multi-Sensor Monitor.

Air Sampling Network shall include all electronics, air solenoid valves,

HEATING, VENTILATION & AIR CONDITIONING

sampling manifolds, firmware, and software as furnished as an integral assembly within the Air Sampling Controller or the Multi-Sensor Monitor. Air Sampling Network shall utilize an internal, factory pre-assembled air sampling manifold to interface to the on-board solenoid valves, and push to connect speed fittings for ease of interface to the Air Sampling Tubing. Romex connectors and knock-outs shall be factory furnished and installed on the Air Sampling Controller and Multi-Sensor Monitor.

The FMS shall utilize a pre-engineered system of Air Sampling Tubing to facilitate net-work wide communications; distribution of low voltage power to Air Sampling Controllers and Multi-Sensor Monitors; and provide a sampling medium for air samples all within a single cable.

232113 Hydronic Piping

CHILLED WATER AND HOT WATER PIPING

All new pipe used in entire system except where otherwise shown or specified, shall be standard weight Schedule 40 black steel pipe with weights and dimensions in accordance with American Standard Association B36-10 as manufactured by National Tube Company, Birmingham Tank Company, Bethlehem Steel Company or approved equal.

At the contractor's option, piping 2" and smaller may be hard drawn copper tubing ASTM B 88 Type "L". Fittings for copper tubing shall be ANSI B16.18 or B16.22 solder joint fittings. Ends of pipe shall be reamed, pipe and fittings cleaned. Use only 95-5 (95% tin and 5% antimony) solder with non-corrosive flux on 1-1/4" and smaller and on 1-1/2" and larger use silver solder (Minimum 12% Silver), with a melting point greater than 10000F.

MAKE-UP WATER PIPING

Make-up water piping above grade, shall be Type "L" hard copper tubing with wrought copper sweated fittings. Copper pipe to conform to ASTM Specifications B-88 and fittings to conform to ASA Specifications B-16-22.

DRAIN PIPING

All drain lines shall be Type "L" hard drawn copper. Drains shall be run in a neat manner to the floor drain and turned down at the floor drain, unless otherwise indicated. Minimum of 1-1/4" unless otherwise shown.

Pressure test all chilled water and hot water piping at a pressure of 150 psig for 24 hours.

232123 Hydronic Pumps

Parallel pumps shall be provided for all applications. Pumps shall be redundant with either capable of handling the building load.

Approved manufacturers:

- ◆ *Bell and Gossett*
- ◆ *Armstrong*
- ◆ *Grundfos*

INLINE PUMPS

The pump shall be of In-Line, close-coupled, single stage, design of bronze fitted construction.

END SUCTION PUMPS

The pump shall be of the end suction design, in cast iron and bronze fitted construction. The pump internals shall be capable of being serviced without disturbing piping connections or motor.

The pump and motor shall be mounted on a common baseplate of heavy structural steel design with securely welded cross members and open grouting area. A flexible coupler, capable of absorbing torsional vibration, shall be employed between the pump and motor, and it shall be equipped with a suitable coupling guard as required. The pumps shall have a foot mounted volute and a spacer drop out for true back pull out service.

DOUBLE SUCTION PUMPS

Casing shall be (close-grained cast iron for working pressures up to 175 psig), and shall be of axially-split design with suction and discharge flanges and mounting feet cast integral with the lower half casing. Tapped and plugged holes shall be provided for priming, vent, drain and gauge connections. Upper half casing shall be removable without disturbing suction or discharge piping.

Where used in a chilled water application, field install a drip pan under the entire pump, motor, and end connections. Drip pan shall be constructed of 16 gauge galvanized sheet steel with welded seams. Drip pan shall be 1-1/2" deep with a 3/4" threaded drain tapping. Interior and exterior of the pan shall have a rust inhibitive coating. Exterior of pan shall be insulated. A 3/4" drain line shall be piped from the pan to the nearest floor drain.

Pump base shall be grouted to the support pad. After grouting the pump base and connecting the suction and discharge piping, the pump and motor shall be realigned in accordance with the standards of the hydraulic institute.

HEATING, VENTILATION & AIR CONDITIONING

232213 Steam and Condensate Heating Piping

All new pipe used in entire system except where otherwise shown or specified, shall be standard weight Schedule 80 black steel pipe with weights and dimensions in accordance with American Standard Association B36-10 as manufactured by National Tube Company, Birmingham Tank Company, Bethlehem Steel Company or approved equal. Pipe to be seamless A106, domestically produced with mill certificates.

Steam Traps: F & T Steam trap shall be open float and thermostatic type of size and capacity as required by the application. The body shall be constructed of cast iron and shall be designed so that the cap and mechanism can be removed without disturbing the piping connections. The body shall be suitable for 150 psig working pressure. Valve and valve seat shall be constructed of heat treated chrome steel. Bucket shall be brass.

Bucket steam trap shall be inverted bucket type of size and capacity as required by the application. The body shall be constructed of cast iron and shall be designed so that the working parts can be removed without disturbing the pipe connections. The body shall be suitable for 150 psig working pressure valve and valve seat shall be constructed of heat treated chrome steel. Bucket shall be brass.

Provide pressure-powered pumps operated by steam pressure which does not require any electrical energy. Pump shall be as manufactured by Spirax Sarco or Watson McDaniel. Unit shall have interchangeable head compatible with standard unit used by Wake forest University. Body construction shall be of cast iron, ductile iron or steel for pumping liquids of specific gravity of .65 and above. The pump shall contain a float operated snap-acting mechanism to open and close the steam inlet and the vent exhaust. There shall be no external seals or packing. Trim shall be stainless steel. Capacity and pressures as indicted on the drawings. Provide 30 gallon receiver, inlet and outlet lift type check valves, inlet strainer, site glass, and inlet and outlet gate valves. Provide vented receiver for draining condensate in open systems or inlet reservoir piping for drainage condensate in closed systems. Receiver or reservoir pipe shall be sized per manufacturer's recommendations. Pump body and operation shall have a maximum working pressure of at least 125 psig. Provide an adjustable direct acting steam pressure reducing valve to regulate steam pressure, and a pressure safety relief valve. Pressure reducing valve shall reduce steam pressure from 150 psi to 50 psi unless noted otherwise on the drawings. Safety relieve valve shall be sized to relieve the capacity of the reducing valve. Set pressure at 115 psig. Provide cycle counter that can communicate with the building automation system.

Pressure test all steam and condensate return piping at a pressure of 150 psig for 24 hours.

232500 Water Treatment

The Contractor will furnish, install and provide all equipment, chemicals and the necessary service for a Water Treatment Program. The water treatment products and service shall be provided by current campus provider.

233000 Air Duct Accessories

Furnish and install, at locations shown on plans, or where required by code, fire dampers constructed and tested in accordance with UL Safety Standard 555. Each fire damper shall have 1-1/2 hour fire protection rating. In addition each fire damper shall include a 2120F fusible link, and shall include a UL label in accordance with established UL labeling procedures. Damper manufacturer's literature submitted for approval prior to installation shall include comprehensive performance data developed from testing in accordance with AMCA Standard 500 and shall illustrate pressure drops for all sizes of dampers required at all anticipated airflow rates. Fire dampers shall be equipped for vertical or horizontal installation as required by the location shown. Fire dampers required by the location shown. Fire dampers shall be installed in wall and floor openings utilizing steel sleeves, angles, other materials and practices required to provide an installation equivalent to that utilized by the manufacturer when dampers were tested at UL. Installation shall be in accordance with the damper manufacturer's instructions. Fire dampers shall be style "A", "B" or "C" as required.

Ventfabrics, Krueger or Duro-Dyne, (Min. 12" x 10" - use 16" x 12" where size permits) insulated doors shall be provided for fire dampers, control dampers, smoke dampers, smoke detectors, and other locations where shown. Door shall be minimum 24 gauge galvanized, double construction with 1" insulation complete collar mounting frame, piano hinges, felt gaskets, cam lock fasteners and handles. Doors shall be labeled as to function, (fire damper, smoke detector, etc.).

Turning vanes and Deflector Controls, Barber-Colman, Carnes Corporation, Krueger or Titus in length up to 18"; Aero-Dyne Duro-Dyne, or Airsan double thickness about 24" in length, installed in rails.

Flexible duct connections shall be provided where ductwork connects to equipment; ventifabrics or Duro-Dyne 28 ounce minimum waterproof and fire retardant woven glass fabric double coated with neoprene, approved by UL. Maximum length of flexible connections shall be 10 inches.

HEATING, VENTILATION & AIR CONDITIONING

MANUAL DAMPERS

American Warming and Ventilating Company Type DAA-P-50, opposed blade, constructed with 15 gauge steel blades. Manual dampers shall be provided with Ventlock No. 637 hand operated locking quadrants located outside of ducts. Locking quadrants shall be elevated 1-1/2" for insulation. Manual dampers 18" x 10" or smaller may be single blade type construction of 16 gauge galvanized sheet metal. Dampers of Ruskin, Krueger, Louvers and Dampers, or Advanced Air, Inc. will be acceptable.

SPLITTER DAMPERS

Install where shown and at duct splits; provide with Ventlock No. 690 self-locking device; constructed of 16 gauge galvanized steel with hemmed leading edge and reinforced at hinged side.

Grilles, registers and diffusers shall be of the type, size and design as shown on the drawings and/or as specified below. Grilles within the same room or areas shall be of the same type and style to provide architectural uniformity. Each supply, return and exhaust device shall be of the proper design as indicated to handle quantities of air within the space with maximum diffusion and without objectionable air movement or noise level.

Turning vanes shall be provided at all tees and square elbows. Turning vanes shall be factory fabricated and designed in accordance with the SMACNA or ASHRAE Guide for formed vanes. The first set of turning vanes on the leaving side of fans shall be of the acoustical type to aid in the elimination of unit noise with the exception of room fan coil units.

Splitter dampers and volume extractors shall be provided in all low velocity ductwork for proper air distribution. Each damper shall be provided, lubricated bearings at both ends of the shafts, adjustments quadrant, and locking devices and shall be constructed of galvanized iron or steel sheet one gauge heavier than the duct in which they are installed. Access doors shall be located at all splitter dampers.

Install access doors at each fire damper and smoke detector. Label all access doors.

233113 Metal Ducts

All ductwork, plenums and casings shall be constructed of sheet metal, as herein specified. All sheet metal construction shall conform to the pressure classification shown on the contract drawings, or herein specified and shall be in accordance with the construction and installation details in Chapter 16 of the

1992 ASHRAE Systems and Equipment Handbook or the appropriate SMACNA Standards.

Low pressure supply ductwork, return air ductwork and exhaust ductwork shall be constructed of zinc coated sheet steel and shall conform to the 1st Edition of SMACNA HVAC Duct Construction Standards -Metal and Flexible, 1985, as follows:

Rectangular Duct 1" w.g. pressure class - Table 1-4.

Round Duct 2" w.g. pressure class - Table 3-2.

Medium pressure ductwork shall be constructed of zinc coated sheet steel and shall conform to the 1st Edition of SMACNA HVAC Duct Construction Standards, 1985, as follows:

- ◆ *Rectangular Duct: 3" w.g. pressure class - Table 1-6.*
- ◆ *Round Ductwork: Medium pressure round duct shall conform to Figure 3-1. (+3" w.g. pressure class).*
- ◆ *Flat Oval Ductwork: Medium pressure flat oval ductwork shall conform to Table 3-4.*

Kitchen exhaust duct shall be constructed of carbon steel in accordance with NFPA Standard No. 96 Chapter 3. All seams and joints shall have a liquid tight continuous external weld. Dishwasher exhaust duct shall be aluminum.

Round or flat oval ductwork exposed to view shall be prefabricated spiral lock seam conduit with prefabricated fittings as manufactured by United Sheet Metal Co., Inc. or equal. Construction shall be an airtight, outer pressure shell, a 1" insulation layer, and a perforated metal inner liner that completely covers the insulation throughout the system. The outer shell shall be manufactured from galvanized steel meeting ASTM A-517-67.

Flexible air duct for connections between medium pressure duct and terminals units and between low pressure duct to diffusers shall be equal to Thermaflex M-KE. Duct shall be listed by Underwriter's Laboratories under UL 181 standards as Class 1 flexible air duct material and shall comply with NFPA Standards 90A and 90B. Duct shall be rated to operate at pressures up to 6" w.g. for sizes 10" and 4" w.g. for sizes 12" and above. Maximum length of flexible air duct shall be 6 feet.

All ductwork must be sealed in accordance with Seal Class C as defined in SMACNA HVAC Duct Construction Standards - Metal and Flexible, 1985.

All joints and seams in ductwork exposed to weather shall be sealed water-tight with a suitable non-aging sealer.

HEATING, VENTILATION & AIR CONDITIONING

Duct hangers and supports shall conform to those shown in Tables 4-1 and 4-2 of SMACNA HVAC Ductwork 1985, 1st Edition.

The installed medium pressure duct system shall be tested to 3" WG.

GREASE DUCT TEST

Prior to the use of concealment of any portion of a grease duct system, a leakage test shall be performed in the presence of the code official. Ducts shall be considered to be concealed where installed in shafts or covered by coatings or wraps that prevent the ductwork from being visually inspected on all sides. The permit holder shall be responsible to provide the necessary equipment and perform the grease duct leakage test. A light test or an approved equivalent test method shall be performed to determine that all welded and brazed joints are liquid tight. A light test shall be performed by passing a lamp having a power rating of not less than 100 watts through the entire section of ductwork to be tested. The lamp shall be open so as to emit light equally in all directions perpendicular to the duct walls. A test shall be performed for the entire duct system, including the hood-to-duct connection. The ductwork shall be permitted to be tested in sections, provided that every joint is tested.

233113 Fabric Air Dispersion System

System shall be used in areas where exposed duct is required (gym for example). Air diffusers shall be as manufactured by Duct Sox and shall be constructed of a woven fire retardant fabric, 100% Flame Retardant and retreated with a machine washable anti-microbial agent from the manufacturer. Color shall be selected by the owner.

Air dispersion accomplished by linear vent and permeable fabric, linear vent to consist of many 3/16" diameter open orifices rather than a mesh style vent to reduce maintenance requirements of mesh style vents. Size of and location of linear vents to be specified and approved by manufacturer.

System shall be installed such that fabric retains its shape when air is not circulating through the duct.

233400 HVAC Fans

CEILING EXHAUST FAN

The fan shall have a forward curved centrifugal wheel. The fan housing shall be constructed of heavy gauge galvanized steel. The housing interior shall be acoustically lined with 1/2" thick insulation. The discharge outlet shall be adaptable for horizontal or vertical mounting.

IN-LINE FANS

The square fan housing shall be four sides of heavy gauge galvanized steel. One of the sides shall be hinged and shall support the motor and wheel assembly allowing the assembly to swing out for cleaning, inspection, or service without dismantling the unit in any way. The motor shall be isolated from the air stream by a motor enclosure and shall draw cooling air from outside the fan housing.

233600 Air Terminal Units

ACCEPTABLE MANUFACTURERS

- ◆ *Envirotech*
- ◆ *Trane*
- ◆ *Titus*
- ◆ *Price*

Terminals shall be pressure independent and shall reset air volume with approximately 5% required air flow as determined by the space sensor regardless of changes in system air pressure. Devices using CFM limiters will not be acceptable.

Discharge sound levels shall not exceed NC-50 at 2" w.g. inlet static pressure when the discharge duct is internally lined with 1.5#/ft³ insulation for the distance shown on the plans. An allowance of 8 db for room absorption is included in the NC requirements.

Radiated sound without allowance for ceiling absorption shall not exceed NC-35 at 2" w.g. inlet static pressure. 15820-2

The casing shall be minimum of 22 gauge steel construction meeting SMACNA or ASHRAE Standards and shall be lined with 3/4" thick dual density fiberglass insulation.

H. Terminals shall be complete with flow sensor, damper, control transformer, etc. Actuator shall be supplied by the FMS contractor and mounted and

HEATING, VENTILATION & AIR CONDITIONING

wired at the factory. They shall be mounted in an easily accessible enclosure.

Terminals shall include a hot water coil where indicated on the drawings. Coil shall be attached to the induction port of the Fan terminal in a manner so as to allow removal for maintenance or cleaning. Coil shall be constructed of pure aluminum fins of .005" to .010" thickness, with die-formed spacers. Fins shall be mechanically fixed to .063" copper tubes for maximum heat transfer. Coils shall be tested at 400 psig.

Fan assembly shall consist of an 18 gauge zinc coated housing with adjustable cut-off and field adjustable discharge/back-draft damper, forwardly curved centrifugal type fan wheel and three speed permanent split capacitor type motor attached to the fan housing with spring vibration isolators. The fan assembly shall be internally suspended and isolated from casing on rubber-in-shear isolators to further minimize vibration. A three speed operating switch (high-medium-low) with an on/off position shall be furnished to select the desired speed tap without the need for field rewiring. The fan motor shall be so manufactured to preclude running in backward rotation.

Fan terminals shall include, where scheduled, an induction port sound baffle internally insulated with 3/4" dual density fiberglass with four pounds per cubic foot skin density, rated for a maximum air velocity of 4500 fpm. Insulation must meet all requirements of UL 181 and NFPA 90-A. Raw edges exposed to the airstream shall be coated and sealed. Induction port baffle shall be constructed of not less than 22 gauge zinc coated steel and shall be designed to be an integral part of the Fan terminals unitized construction. The sound baffle shall be certified to produce a minimum 5 NC reduction in radiated noise levels.

Fan terminal shall include where scheduled, a separate discharge sound attenuator at least 30" long, with internal acoustical splitter. Attenuator casing shall be constructed as specified for Fan terminal. In determining the requirements of a silencer to meet an NC 35 in the space, no credit is to be taken for lined ductwork or for acoustic power splits for multiple diffusers. Sound data include such factors, a letter of factory certification shall accompany the sound data submittal guaranteeing that the equipment will meet the noise criteria specified.

235700 Heat Exchangers for HVAC

Subject to compliance with the Drawings and Specifications, provide one of the following, or equal approved in writing by the Owner:

- ◆ *Bell and Gossett*
- ◆ *Armstrong*

The shell shall be constructed of 316 stainless steel. Connections shall be carbon steel pipe with 150 lb. ASA flanges for ease of installation.

The shell and tube bundle shall each be tested at 190 psig air under water.

Tubes shall be corrosion resistant copper, with enhanced surface designed, formed and tested by the heat exchanger manufacturer. Baffles shall be glass-filled polypropylene and shall support the tubes. They shall be oriented so as to direct the shell-side fluid over the tubes in a spiral flow pattern. Tubes shall be individually replaceable without the need for rolling, welding or brazing.

Water boxes shall be marine type. At least one end must be easily removable without disturbing the system piping to allow access for tube inspection and/or cleaning. All connections shall be carbon steel pipe with 150 lb. ASA flanges for ease of installation.

Furnish with the unit an extra set of gaskets and bullet inserts for changing the gasket.

237200 Make-Up Air Unit

237313 Modular Indoor Central Station Air Handling Units

ACCEPTABLE MANUFACTURERS

- ◆ *Trane*
- ◆ *Carrier*
- ◆ *McQuay*
- ◆ *York*

Provide unit mounting legs to support all sections of unit and raise unit for proper trapping. Contractor will be responsible for providing a housekeeping pad when unit mounting device is not of sufficient height to properly trap unit. Unit mounting devices not constructed of galvanized steel shall be chemically cleaned, coated with rust inhibiting primer, and finished 15640-3 with rust inhibiting enamel.

Unit shall be constructed of a complete structural frame with removable panels. Removal of side panels shall not affect the structural integrity of the unit.

HEATING, VENTILATION & AIR CONDITIONING

Contractor shall be responsible to provide connection flanges and all other framework that is needed on unit to ensure that removal of unit's panels shall not affect structural integrity. Manufacturer shall be able to ship each segment (filter, coil, fan) separate so that unit can be broken down for ease of installation in tight spaces

Panels shall be fully removable to allow for a proper way to thoroughly clean panels of microbial growth and to access internal parts. If panels are not removable, then manufacturer shall provide access sections with doors between all internal components to ensure access and cleanability of the air handler.

All exterior panels and structural frames shall be constructed of G90-U galvanized steel (minimum of 6 oz/sq.ft. zinc). Casings not constructed of G90-U galvanized steel, casings with welds on exterior surfaces, or casings with welds on interior surfaces that have burned through to exterior surfaces shall be chemically cleaned, coated with rust inhibiting primer, and finished with rust inhibiting enamel in order to prevent premature corrosion and microbial growth.

Casing shall have full size removable access doors as scheduled on drawings. Access doors shall have double wall construction. Provide automotive style neoprene gasketing around full perimeter of access doors to prevent air leakage. Provide "ventlock" style non-corrosive alloy latches operable from the inside or outside of unit. Provide safety latches that allow access doors to partially open after first handle movement and fully open after second handle movement. Access doors shall open against unit operating pressure.

Insulate casing sections with 2" thick, 3 pound per cubic foot density fiber glass insulation or equivalent. Provide double wall (min. 18 gauge) casing construction and encase insulation between solid exterior and solid interior casing panels such that no insulation is exposed to airstream. Foil facing on insulation is not acceptable as alternate to double wall construction. Insulation shall comply with NFPA 90A.

Unit drain pan shall be constructed of 316 stainless steel and insulated to prevent sweating. The bottom of the drain pan shall be sloped in two planes that pitch the condensate to the drain connection.

Provide supply fan section(s) with backward incline, double inlet centrifugal fan designed and suitable for class of service indicated in the unit schedule. Fan shaft to be properly sized and protectively coated with lubricating oil. Fan shafts shall be solid and properly designed so that fan shaft does not pass through first critical speed as unit comes up to rated RPM. Fans shall be statically and dynamically tested as an assembly at the required RPM to meet design specifications. Key fan wheels to fan shaft to prevent slip-ping.

Provide self-aligning, grease lubricated pillow-block ball bearings selected for L-10 200,000 hour average life per ANSI/AFBMA 9. Extend both grease lubrication fittings to drive side of unit with plastic tubes and zerk fittings rigidly attached to drive side bearing support.

Belts shall be enclosed as required by OSHA standard 29 CFR 1910 to protect worker from accidental contact with the belts and sheaves.

for fan sections controlled by variable frequency drives, balance at all speeds between 25% and 100% of design RPM.

Coils shall be manufactured by the same company as the supplier of the air handling unit. Install coils such that headers and return bends are enclosed by unit casings. Coils shall have copper coils with aluminum fins.

Construct coil casings of 304 stainless steel with formed end supports and top and bot-tom channels. If two or more coils are stacked in unit, install intermediate drain channels between coils to drain condensate to main drain pans without flooding lower coils or passing condensate through airstream.

Coils shall be proof tested to 300 psig and leak tested to 200 psig air pressure under water.

Provide factory-fabricated filter section of the same construction and finish as unit casings. Filter sections shall have filter guides and full height, double wall, hinged, removable access doors for filter removal. Construct doors in accordance with specifications. Provide filter blockoffs as required to prevent air bypass around filters. Provide 2" Farr 60% pleated filter or equivalent. Filters used during construction are to have a minimum MERV rating of 8, which must be replaced with MERV 13 filters prior to occupancy.

Provide a UVC Emitter. Emitter and fixture shall be factory assembled and tested. They shall consist of a housing, power source, reflector, Emitter sockets and Emitter.

The housing shall be constructed of 304 stainless steel to withstand HVAC environments. The reflector shall be constructed of heavy gauge, specular finished aluminum alloy with approximately 85% reflectance at 254 nm wavelength. The housing shall be equipped with ½" electrical conduit openings on each end to facilitate coupling and wiring fixture-to-fixture and to power. All components shall be in one integral assembly to maximize serviceability.

The power source shall be a Class P2, electronic, rapid start type with a power factor greater than 0.95 and a power conversion of greater than 75%. The power supply design shall include RF and EMI suppression. The power supply shall be designed to maximize photon production, irradiance and reliability in cold or moving airstreams of 35-170°F, 100% RH and up to 2000 fpm velocity. The fixture

HEATING, VENTILATION & AIR CONDITIONING

shall be 115 Vac, 60 Hertz, and single phase.

The Emitter tube shall be a very high output, hot cathode, T5 diameter, medium bi-pin type that produces broadband UVC of 250-260 nm. Each tube shall produce the specified output at 2000 fpm velocity and air temperatures of 35-170°F. It shall produce no ozone or other secondary contaminants.

Unit shall comply with UL Standard 1995 for use in HVAC equipment and shall carry the “UL” and ULC” labels.

Contents

26-02	Regulations and Compliance	26-26	Duct Bank Installation
26-02	Record Drawings	26-26	Trenching and Backfilling
26-02	Electrical Testing	26-28	Electrical Metering Devices
26-04	Excavation	26-28	Secondary Distribution Equipment
26-04	Sleeves, Cutting, and Patching	26-30	Surge Protection Device System (SPD)
26-04	Painting and Finishing	26-31	Modular Surge Protection for Service Entrance/Main Distribution and Critical Equipment Applications
26-05	Short Circuit/Coordination Study	26-32	Non-Modular Surge Protection for Distributon, Sub-Distribution and Branch Circuit Panels
26-06	Arc Flash Calculations	26-32	Switchboards
26-06	Equipment Connections and Coordination	26-36	Panelboards
26-08	Basic Materials and Methods	26-38	Motor Control Centers
26-09	Raceways and Fittings	26-38	Dry Type Building Transformers
26-12	Conductors	26-39	Lighting Fixtures and Accessories
26-14	Grounding and Bonding	26-41	Lamps
26-16	Boxes	26-41	Ballasts
26-18	Wiring Devices	26-42	Led Drives
26-19	Raceway and Outlet Systems	26-43	Emergency Exit Luminaire
26-20	Motor Controllers	26-44	Emergency Egress Luminaire
26-21	Miscellaneous Devices	26-45	Light Fixture Installation
26-23	Pad-Mounted Distribution Transformer	26-46	Low Voltage Switching Systems
26-24	Pad-Mounted Loop Interrupter Switchgear	26-50	Engine-Generator System
26-24	Medium Voltage Cable	26-53	Automatic Transfer Switch
26-24	Medium Voltage Cable Splicing and Termination	26-55	Lightning Protection System
26-25	Medium Voltage Surge Arresters – Elbow Interface	26-56	Fire Alarm System, Addressable
26-25	Electrical Duct Bank System		

Regulations and Compliance

The requirements of the North Carolina State Building Code which includes the National Electrical Code, and of all other State and Local codes, ordinances, regulations and interpretations by authorities having jurisdiction are binding upon this Contractor, and nothing contained in, or inferred by, these specifications or the applicable drawings may be construed as waiving those requirements. The latest edition of the National Electrical Code, referred to herein and on the drawings as “N.E.C.”, forms a part of these specifications; and under no circumstances may the installation fail to meet the minimum requirements therein.

This Contractor shall secure and pay for all permits, fees, inspections and licenses required. Upon completion of the project and prior to his request for final payment he shall present to the Architect/Engineer a certificate of inspection and approval from the inspection authorities.

All materials furnished and all work installed shall comply with the National Fire Codes of the National Fire Protection Association, and with the requirements of all governmental departments having jurisdiction.

All materials and equipment shall bear the approval label, and shall be listed by the Underwriters’ Laboratories, Inc.

It is the responsibility of the contractor to notify the local electrical inspector to schedule the required inspections.

Record Drawings

During construction of this project, the Contractor shall maintain one complete set of electrical contract drawings, on which shall be recorded all significant changes. This set of drawings shall be used for no other purpose. Upon completion of the work, the Contractor shall submit these drawings to the Architect/Engineer for approval and presentation to the Owner.

Electrical Testing

Conduct full scale tests with all lights, equipment and appliances in operation and prove the electrical system satisfactory for operation and free from defects. Promptly remedy all defects.

All current carrying phase conductors and neutrals shall be tested for insulation resistance and accidental grounds as installed, before connections are made. This shall be done with a 1000V megger. Minimum readings shall be one million or more ohms for #6 AWG wire and smaller, 250,000 ohms or more for #4 AWG wire or larger, between conductors and between conductor and the grounding conductor.

ELECTRICAL GUIDELINES

After all fixtures, devices and equipment are installed and all connections completed to each panel, the contractor shall disconnect the neutral feeder conductor from the neutral bar and the grounded enclosure. If this reading is less than 250,000 ohms, the contractor shall disconnect the branch circuit neutral wires from this neutral bar. He shall then test each one separately to the panel and until the low readings are found. The contractor shall correct troubles, reconnect and retest until at least 250,000 ohms from the neutral bar to the grounded panel can be achieved with only the neutral feeder disconnected.

At final inspection, the contractor shall furnish a megger and show that the panels comply with the above requirements. He shall also furnish a hook-on type ammeter and voltmeter to take current and voltage readings as directed.

Upon completion of installation of the electrical grounding and bonding systems, the ground resistance shall be tested with a ground resistance tester utilizing the IEEE Fall-of-Potential method of testing. Where tests show resistance-to-ground is over 25 ohms, appropriate action should be taken to reduce the resistance to 25 ohms, or less, by driving additional ground rods. (The compliance should be demonstrated by retesting).

If provided, ground fault protection on new circuit breakers shall be performance tested in the field and properly calibrated and set in accordance with the coordination study.

At the completion of the project, submit 3 sets of complete operating and maintenance instructions.

Except where reuse of existing items are specifically indicated or permitted, all materials and equipment shall be new and shall conform to the standards of the National Electrical Manufacturer's Association and Underwriters Laboratories, Inc. in every instance where such a standard has been established for the item involved.

Materials shall be inspected by the Contractor upon their arrival at the site to be sure they are correct. Material and equipment stored on the site shall be protected against physical damage, dirt and damage caused by precipitation, wind, condensation, excessive humidity, and extremes of temperature. Materials shall be stored in their original cartons within substantial, clean and dry storage facilities provided under this Contract. Conduit, large galvanized boxes, and lighting poles may be stored outdoors on suitable blocks or racks clear of the earth and undergrowth, and pitched to drain. Large electrical equipment intended for ultimate installation outdoors may be stored in the weather on suitable blocks or platforms clear of the earth and undergrowth, and with interior lamps or space heaters continuously energized to prevent condensation. Alternate storage

ELECTRICAL GUIDELINES

provisions may be submitted to the Architect/Engineer for approval prior to the arrival of the material. Under no circumstances shall equipment be stored in the weather under a cover of polyethylene or tarpaulin. The Architect/Engineer will be the sole judge as to the acceptability of storage facilities, and when directed by the Architect/Engineer, improperly stored or damaged material shall be removed from the site and replaced with new material.

Excavation

Trenching and shoring shall comply with requirements of North Carolina State Department of Labor's regulations entitled "Safeguards During Construction", and "Trenching and Shoring". In backfilling pipe trenches, approved fill shall first be compacted firmly and evenly on both sides of pipe in 6" layers to a depth of 12" over the top of the pipe. Remainder of trench shall be backfilled to established grade in 6" layers. The Contractor must compact between each layer with a high-frequency vibrator tamper such as Dart Soil Compactor (as manufactured by Dart Manufacturing Company, Denver, Colorado). Fill shall be compacted to density specified in Earthwork Section for the area through which trench is cut. Where compaction requirements are not established for an area, the Contractor must compact fill to 95% maximum density at optimum moisture content.

Sleeves, Cutting, and Patching

Contractor shall place his own sleeves and advise other trades of required chases and openings so they can be properly built in. Sleeves provided under this division shall be formed out of no less than schedule 40 galvanized rigid steel conduits. Where any raceway supports installed under this Contract pierce the roof, suitable pitch pockets shall be provided and coordinated with the roofing contractor as necessary to be acceptable to the Architect/Engineer. Provide suitable fittings where any raceways or equipment cross expansion joints.

Painting and Finishing

Suitable finishes shall be provided on all items of electrical equipment and materials which are exposed. This shall consist of either an acceptable finish as manufactured and supplied to the job or application of suitable finishes after installation. Where installed in finished areas, exposed equipment and materials shall be supplied with prime coat, and shall be professionally painted or enameled as directed to match or blend with adjacent surfaces. In unfinished areas such as equipment rooms, exposed equipment shall be furnished with suitable factory

ELECTRICAL GUIDELINES

applied finishes (e.g. standard gray enamel finish for panelboards, etc.). Equipment furnished in finishes such as stainless steel and brushed aluminum shall not be painted.

Paint material shall be selected from the products listed below and, insofar as practical, products of only one manufacturer shall be used. Should the Contractor desire to use products of a manufacturer not listed below, or products made by a listed manufacturer but not scheduled herein, Contractor shall submit complete technical information on the proposed products to the Architect/Engineer for approval.

Rust Inhibitive Primer:

- ◆ *Devoe Bar-Ox Quick Dry Metal Primer, Red.*
- ◆ *Duron Deluxe Red Primer.*
- ◆ *Glidden Rustmaster Tank and Structure Primer.*
- ◆ *Pittsburgh Inhibitive Red Primer.*

Galvanized Metal Primer:

- ◆ *Devoe Mirrolac Galvanized Metal Primer.*
- ◆ *Duron Deluxe Galvanized Metal Primer.*
- ◆ *Glidden Rustmaster Galvanized Iron Metal Primer.*
- ◆ *Pittsburgh Speedhigh Galvanized Steel Primer.*

Short Circuit/Coordination Study

The result of the short circuit and coordination study shall be summarized in a final report. Study software preference is SKM Power tools. Provide an electronic copy of the study to the Owner.

The short circuit and coordination study shall be conducted under the supervision and approval of a Registered Professional Electrical Engineer skilled in performing and interpreting the power system studies.

The Contractor shall furnish all data as required by the power system study. The Engineer performing the short circuit and coordination studies shall furnish the Contractor with a listing of required data immediately after award of the contract. The Contractor shall expedite collection of the data to assure completion of the studies as required for final approval of the distribution equipment shop drawings and/or prior to the release of the equipment for manufacturing.

Proposed protective device coordination time-current curves shall be graphically displayed on log-log scale paper. Include on each curve sheet a complete title and one-line diagram with legend identifying the specific portion of the

ELECTRICAL GUIDELINES

system covered. Terminate device characteristic curves at a point reflecting maximum symmetrical or asymmetrical fault current to which device is exposed. Identify device associated with each curve by manufacturer type, function, and, if applicable, tap, time delay, and instantaneous settings recommended.

Arc Flash Calculations

The result of the arc flash calculations shall be summarized in a final report. Calculation software preference is SKM Power tools. A label based on the results of the arc flash calculations shall be provided for each electrical equipment component likely to require examination, adjustment, servicing or maintenance while energized. Provide an electronic copy of the calculations to the Owner.

Equipment Connections and Coordination

HEATING, VENTILATING, AIR CONDITIONING, REFRIGERATION AND PLUMBING EQUIPMENT:

Unless otherwise indicated, provide all power wiring, including feeders and branch circuits, to the terminals of the equipment, including mounting of motor starters; feeder and branch circuit over-current protection; disconnecting means within sight of each motor and each starter.

ELEVATOR EQUIPMENT:

Provide an elevator equipment power circuit, including a panelboard/switchboard mounted shunt-trip circuit breaker, a fused disconnect switch with fuses as sized by Elevator Manufacturer, and connection to the elevator controller. Provide elevator fused disconnect switch with two sets of form C auxiliary contacts for use by the elevator installer to disconnect the elevator controller internal battery from the power supply when the elevator disconnect switch is opened. Provide a duplex NEMA 5-20R receptacle adjacent to the disconnect switch (or switches where there is more than one controller in the machine room) connected to a dedicated circuit. Provide a 20 amp, 120 volt dedicated circuit with 30 amp, heavy duty, fused disconnect switch (from emergency source when available) for car lighting. Terminate circuit on controller as directed by elevator installer. Provide a 20 amp, 120 volt dedicated circuit with 30 amp heavy duty, fused disconnect switch for control power. Terminate circuit on controller as directed by elevator installer. Provide telephone raceway to the elevator controller from the nearest telephone backboard or cable tray. The raceway shall consist of a 3/4" concealed conduit complete with nylon pull cord. Terminate at the controller as

ELECTRICAL GUIDELINES

directed by elevator installer. Provide pit lighting fixtures and switch and pit receptacles (5-15R GFI). Provide fire alarm system relay contacts to signal each elevator controller that shall be activated whenever smoke or by-products of combustion are detected in any of the elevator lobbies served by the elevator, in the elevator hoist way or in elevator machine room. Run No. 14 AWG conductors in raceway from relay contacts to the applicable elevator controller. Terminate as directed by elevator installer. Provide two No. 14 AWG conductors in raceway from the emergency system automatic transfer switch to the elevator controller to signal elevator controller that power has been transferred from normal source to emergency source. Terminate as directed by elevator installer. Provide two No. 14 AWG conductors in raceway from the automatic transfer switch to the controller to provide advance notification that transfer will occur, for emergency-to-normal transfers and for, in test mode only, for normal-to-emergency transfers. Terminate as directed by elevator installer. In elevator shafts that are sprinkled, provide required heat detectors for shunt tripping power to elevator controller. Location shown on drawings for elevator related work is diagrammatic only. Contractor shall locate electrical equipment, including lighting fixtures, in elevator equipment room and elevator pit, and shall make all connections to elevator equipment, as directed by elevator installer.

KITCHEN EQUIPMENT:

Unless otherwise indicated, provide all power wiring, including feeder and branch circuit protection and disconnects, to the terminals of the equipment, including the mounting of motor starters; provide all control wiring necessary for the proper operation of the equipment including the mounting of control devices; provide type SO flexible cords with grounding conductors and proper caps necessary for connection of equipment to receptacles indicated; and provide effective and permanent equipment grounding of all electrically operated equipment.

CONTROLS:

Unless otherwise indicated, individually mounted motor starters should be furnished as part of the Division furnishing the driven equipment. Unless otherwise indicated, remote control wiring for Heating, Ventilating, Air Conditioning, Plumbing, and Elevator equipment will be provided as part of those respective Divisions.

Basic Materials and Methods

Unless otherwise indicated or specified, the Wiring Method for this project shall consist of copper conductors with 600 volt insulation installed in metal raceways.

Acceptable fastening methods include wood screws and nails on wood construction, toggle bolts on hollow masonry, expansion bolts and lead anchors on brick and concrete, and machine screws on metal surfaces. Explosive fasteners may be used in steel and concrete in accordance with the manufacturer's recommendations. Wire, perforated metal strap, and wooden plugs are not acceptable as fastening material.

Materials used shall be good quality, made of zinc or cadmium coated steel or other non-corroding material. Materials, whether exposed or concealed, shall be firmly and adequately held in place. Fastening and support shall afford safety factor of three or higher, and shall be in full compliance with the seismic protection requirements of the N.C. State Building Code.

Fixtures, raceways, and equipment shall be supported from the structure. Nothing may be supported on suspended ceiling. Equipment and raceways attached to outside walls, or interior walls subject to permanent moisture, shall be shimmed out with non-corrodible material so as to provide 1/4" air space between wall and equipment or raceway.

Suitable nameplates shall be provided for the identification of electrical equipment including Switchboards, Panelboards, Motor Control Centers, Dry-Type Transformers, Motor Starters, Safety Switches, and Circuit Breakers. Nameplates shall be of engraved white core plastic laminate, not less than 1/16" thick. Nameplate identification shall include equipment name, source of power supply and voltage. Engraving shall be of professional quality, with block style letters, minimum 1/4" high. Nameplates shall be attached with quality adhesive.

All empty conduit runs and conduit with conductors for future use shall be identified for use and shall indicate where they terminate. Identification shall be by tags with string or wire attached to conduit or outlet.

for any raceway passing through an exterior wall, above or below grade, provide appropriate sleeve and water proofing. Center the conduit in the sleeve and fill the space between conduit and sleeve with appropriate compound such as lead and oakum, and then apply caulking compound, Thiocaulk or approved equal, flush with the wall surfaces.

for raceways penetrating floor slabs, smoke partitions, and fire-rated walls, provide steel pipe sleeves and seal with high-temperature non-shrink grout or other material as approved by the Architect/Engineer. Materials and installation

ELECTRICAL GUIDELINES

methods shall be UL listed as a Through-Penetration Firestop System suitable for use with the UL Fire Resistance Design encountered. Refer to the UL fire protection details shown on the drawings.

Conduits penetrating roof surfaces for purpose of connecting to roof-top mechanical equipment shall utilize openings and curbs provided for the equipment where possible.

for other raceway penetrations through the roof the Contractor shall provide appropriate prefabricated roof curb assemblies - "Pipe Portal System" as manufactured by Roof Products and System Corp., Addison, Illinois or equal method as approved by Architect/Engineer and Roofing Subcontractor.

Raceways and Fittings

All wiring shall be installed in raceways.

Metal raceway and components shall be as manufactured by Allied, Triangle, Wheatland, Thomas & Betts or other approved manufacturers.

Non-metallic raceway system components shall be as manufactured by Carlon, Queen City Plastics, Iplex or other approved manufacturers.

Rigid Metal Conduit shall be zinc coated Schedule 40 steel or alloy 6063-T42 aluminum with threaded couplings and fittings. Termination at sheet metal enclosures shall consist of double locknuts and insulating bushings. Rigid Steel conduit shall be used for all exposed and concealed work except where other raceways are indicated or permitted. Aluminum conduit complete with aluminum fittings may be used in lieu of steel conduit except in wet locations, underground, or in poured concrete. Steel and aluminum shall not be mixed in the same run of conduit.

Intermediate Metal Conduit (IMC) with threaded couplings and fittings may be used for exposed and concealed work in lieu of rigid metal conduit except underground outside the building foundation, or where supporting lighting fixtures, or in hazardous locations, or where exposed to severe impact or injury. Termination at sheet metal enclosures shall consist of double locknuts and insulating bushings. IMC may only be used in mechanical equipment rooms by approval of the Owner.

Electrical Metallic Tubing (EMT) of 2" maximum size may be used for concealed work in lieu of Rigid Metal Conduit except underground or in poured concrete. EMT of 2" maximum size may be used for exposed work in lieu of Rigid Metal Conduit except outdoors, or above a roof, or where supporting lighting fixtures, or where exposed to severe impact or injury, or in hazardous locations, or less than 10 feet above a floor or platform in other than in electrical or

communications closets or equipment rooms. EMT may not be used in mechanical equipment rooms.

Rigid PVC Conduit shall be Schedule 40, UL listed for use with 900C. Conduit run underground or run in or under a poured concrete slab shall be rigid PVC. Vertical elbows and vertical extensions from underground or concrete embedded PVC conduits smaller than 3" trade size may also be of PVC provided that they remain concealed or otherwise protected, but shall be of Rigid Steel Conduit (or IMC where permitted) where they stub up into exposed locations or trade size is 3" or larger. An insulating bushing or end bell shall be provided at each termination. Conduit run underground and not under a poured concrete slab shall have installed continuously above it a warning tape. Tape shall be 12 inches wide, centered on conduit and located 12 inches below finished grade.

Flexible Metal Conduit shall be zinc-coated steel of a length no more than 5 feet. It shall be used in lieu of Rigid Metal Conduit for connections to moving or vibrating apparatus, recessed lighting fixtures, dry-type transformers, and motors. Flexible Metal Conduit may be used where rigid connections are impractical due to obstructions or space limitations. Flexible Metal Conduit used in wet, damp, or corrosive location shall be PVC jacketed liquid-tight complete with liquid-tight connectors.

Fittings for steel conduit and tubing shall be of zinc coated steel or malleable iron. Plastic insulating bushings provided for Rigid and Intermediate Metal Conduits shall be rated for 1500C. Bonding bushings shall be steel or malleable iron with non-removable plastic throats rated 1500C. EMT fittings shall be the compression type. Set-screw, indenter, pressure cast, and die cast fittings are not acceptable. Connectors for EMT, Flexible Metal Conduit and Liquid-tight Flexible Metal Conduit shall be the insulated-throat type. Connectors for Flexible Metal Conduits shall be of the "Tite-Bite" design.

Conduit expansion fittings shall be of zinc coated cast or malleable iron and steel conduit, complete with flexible bonding straps. Expansion fittings shall allow longitudinal conduit movement of 4 inches.

Minimum raceway size shall be 1/2", except Flexible Metal Conduit connections to individual lighting fixtures may be 3/8". Raceway sizes, unless indicated on the drawings, shall be determined by the Contractor in accordance with NEC requirements for type THW insulated conductors, or the actual insulation used if it is thicker than type THW.

Rigid and Intermediate Metal Conduits shall be made up with full threads, to which a conductive pipe compound (T & B Kopr-Shield or equal) has been applied and butted in coupling. Terminations at sheet metal enclosures in indoor

ELECTRICAL GUIDELINES

dry locations shall be made with double locknuts and an insulating bushing. Terminations at sheet metal enclosures in outdoor, damp, and wet locations shall be made with threaded conduit hubs of zinc coated malleable iron.

Except where run under a concrete slab on grade, underground conduits shall be a minimum of 30" below grade.

All underground conduits shall have metalized warning tape installed above the conduit that identifies the specific system buried below. The warning tape shall consist of a minimum 3.5 mil solid foil core encased in a protective plastic jacket (total thickness 5.5 mils). Tape shall be 6 inches wide with black lettering imprinted on a color coded background that conforms to APWA color code specifications. Tape shall be installed 18 inches above the conduit and in no case less than 6 inches below grade.

Installation of PVC conduit shall be in accordance with the manufacturer's recommendations using solvent welded couplings and fittings. Field bends shall be made with approved heating equipment. Open flames are not permitted. An insulating bushing or end-bell shall be provided at each termination.

Conduits shall be rigidly supported not more than 8 feet on center and shall be concealed within walls, ceilings, and floors, except as indicated or specifically approved by the Architect/Engineer; kept at least 6" from flues and steam or hot water pipes; and protected against the entry of dirt, plaster, or trash. Raceways shall be supported independently of suspended ceiling members and suspension wires.

Suspended EMT shall be provided with additional hangers at elbows and bends, and where necessary to avoid strain at couplings and connectors.

Exposed conduits, where permitted, shall be run parallel or perpendicular to walls, structural members and ceilings; with right-angle turns consisting of symmetrical bends or cast metal fittings with threaded hubs. Offsets may be used where necessary provided that they are of minimum length.

Conduits crossing expansion and contraction joints shall cross perpendicular to the joint and shall be provided with expansion fittings. Conduits shall not be embedded in the concrete slabs at the expansion and contraction joints.

Conduit may not be installed laterally in any concrete slab where the outside diameter of the conduit, measured at a coupling, exceeds one-third the thickness of the concrete. Conduits shall occupy the middle third of the slab when practical and leave at least 3/4 inch concrete cover. Where reinforcing bars occur at the 3/4 inch level the conduit shall be run inside them toward the center of the slab. Conduits may cross each other within the slab provided the 3/4 inch concrete cover is maintained. Conduits shall be tied to the reinforcing rods or otherwise

supported when necessary to prevent sagging when concrete is poured. They shall be laterally spaced not closer than three diameters on centers to allow complete coverage.

Immediately after installation, conduit openings shall be covered to prevent entrance of foreign matters. Covers shall remain in place throughout the rough-in stage.

Conductors

Insulated conductors shall be as manufactured by Rome, Tri-angle, Southwire, or approved equal.

All wire and cable conductors shall be copper.

Conductors shall be not smaller than #12 AWG except that #10 AWG minimum is required for the entire length of 120 volt branch circuits whose distance to the center of the load exceeds 75 feet. #14 AWG may be used for signal and remote control circuits. #16 AWG may be used for taps to individual recessed lighting fixtures on circuits protected by over-current devices rated at 20 amperes or less and contained within flexible metal conduits that do not exceed 6 feet in length. Conductors #10 AWG and smaller shall be solid, dual rated type THWN/THHN.

Conductors #8 AWG and larger shall be stranded, dual rated type THWN/THHN.

Each conductor shall bear easily readable markings along entire length, indicating size and insulation type.

Insulation on conductors #10 AWG and smaller shall be suitably colored in manufacture.

Conductors in any location subject to abnormal temperature shall be furnished with an insulation type suitable for temperature encountered.

Where no indication is made of wire size, the conductor shall be of N.E.C. size to match its over-current protective device, but in no case smaller than #12 AWG.

Splices in conductors #10 AWG and smaller shall be made with twist-on spring steel devices UL listed as Pressure Cable Connectors, with integral insulating covers rated 75 degrees C at 600 volts, except that those used for connections to lighting fixtures and other heat-producing equipment shall comply with temperature ratings marked on the equipment but not less than 90 degrees C.

Splices in copper conductors #8 AWG and larger shall be made with mechanical devices UL listed as Pressure Cable Connectors and insulated with thermoplastic tape UL listed for use as sole insulation. Tape may be omitted from connectors supplied with securely fastened insulating covers which completely

ELECTRICAL GUIDELINES

enclose the connector and the conductors. Insulating covers shall be rated 75 degrees C at 600 volts.

Connect solid wires to equipment, switches, and devices equipped with binding screw terminals by looping the wire under the screw head in such a manner that the loop is tightened as the screw is tightened. Straight-in wiring under screw terminals is not acceptable.

Stranded wires shall not be inserted into back-wiring holes on devices, nor shall they be directly connected to screw head terminals. They shall be fitted with insulated crimp-on type spade terminals for connection under the screw head.

All wiring shall be color coded. On 120/208V, 3 phase, 4 wire power systems, conductor insulation shall be color coded Black (Phase A), Red (Phase B), Blue (Phase C), and White (Neutral). On 277/480V, 3 phase, 4 wire systems, conductor insulation shall be color coded Brown (Phase A), Orange (Phase B), Yellow (Phase C), and Gray (Neutral).

Insulation for grounding conductors on all systems shall be Green. Isolated ground conductors shall be additionally identified with a yellow stripe run full length of the insulation. Conductors #8 AWG and larger may be identified with two or more bands of proper color plastic tape applied near each splice and termination. Painting of wire will not be acceptable.

Phase sequence shall be “A”, “B” and “C” from left to right, top to bottom or front to back when facing equipment.

Control and signal wiring shall not use the above-named colors except green for grounding. Any other colors or striping may be used but the coding shall provide same color or striping between any two terminals being joined.

Switch legs, including “Travelers”, shall be the same color as phase circuit conductors.

Three-phase circuits shall be limited to one such circuit per raceway. They shall consist of three different phase wires, and a neutral where required.

A neutral shall not serve more than one circuit. The neutral carrying all or any part of the current of any specific load shall be contained in the same raceway or enclosure with the phase wire or wires also carrying that current.

Each feeder and each set of service conductors shall be installed in a separate raceway.

Where paralleling of conductors is shown for feeders or service entrance, it is absolutely required they be exactly the same length between terminations.

Where service or feeder conductors are so installed that the conductor markings cannot be read without moving or twisting conductors, they shall be provided with suitable tags indicating the conductor size and insulation.

Grounding and Bonding

Grounding conductors shall be of THWN insulated copper, unless otherwise indicated.

Grounding bus bars in distribution equipment shall be bare copper.

Aluminum and aluminum alloys are not acceptable as grounding materials.

Clamps for attaching conductors to water pipes and ground rods shall be of bronze. Ground rod clamps shall be U.L. listed for direct burial.

Clamps for attaching conductors to building steel shall be of steel, bronze, or malleable iron.

Threaded hubs for bonding metal raceways to the contained grounding electrode conductors and to the water pipe clamps shall be of bronze or malleable iron. Similar hubs shall be used to bond the same raceways to the conductors and to sheet metal equipment enclosures.

Driven grounding electrodes shall consist of copper clad steel rods. Rods shall be 10 feet long and 3/4" diameter unless otherwise indicated.

Bonding bushings shall be of steel or malleable iron with non-removable plastic throats rated 150 degrees C.

Bonding locknuts and wedges for service conduits shall be of zinc coated steel.

All non-current-carrying metal parts, raceways, and enclosures of the electrical system and of equipment supplied through the electrical system shall be permanently and effectively grounded.

Equipment grounding conductors shall be provided for each feeder and for each branch circuit and shall be contained within the same raceways as the feeder and branch circuit conductors. The equipment grounding conductor shall be THWN insulated copper, not smaller than #12 AWG.

Where isolated grounds are indicated, or required to serve isolated ground type receptacles, provide two equipment grounding conductors of equal size; one to ground raceways, boxes, and other enclosures; the other to connect to the isolated grounding terminals on the equipment or its special receptacle. Both grounding conductors shall be provided in each branch circuit and each feeder raceway back to the point where the service neutral, or the separately derived system neutral, is connected to ground.

Copper bonding strips normally included in small sizes of liquid-tight flexible metal conduit and dependent upon the terminal connectors for bonding continuity will not be accepted in lieu of the equipment grounding conductors required above.

Grounding terminals on wiring devices, other than isolated ground

ELECTRICAL GUIDELINES

receptacles, but including switches, shall be connected to the equipment grounding conductor included in the branch circuit raceway, and to the device box with suitable jumpers and lugs bolted to the box, not the plaster ring. “G” clips are not acceptable, and “self-grounding” type device mounting screws will not be accepted as the device grounding method.

Where metal raceways enter sheet metal enclosures through knockouts provide bonding bushings and jumpers to the enclosure under any of the following conditions: voltage exceeds 250 volts to ground, branch circuit conduit exceeds 1” in size and feeder conduit regardless of voltage and size.

All metal piping systems including water piping, gas piping and sprinkler piping shall be permanently and effectively bonded to the electrical equipment ground system as required by N.E.C. 250. Structural metal systems shall be permanently and effectively bonded to the electrical grounding electrode system as required by N.E.C. 250. The lightning protection system shall be permanently and effectively bonded to the electrical grounding electrode system as required by N.E.C. 250.

The grounding electrode system for the service neutral and service equipment shall include a connection to the water main at the nearest accessible point to where it enters the building and on the street side of the main valve. This connection shall remain accessible after construction is complete.

A ground rod using #4 AWG copper conductor. Ground rods shall be driven to a depth equal to their length plus six inches. Provide additional ground rods not less than 10 feet apart where needed to comply with NEC ground resistance limitations, and resistance limitations specified herein.

Structural metal building frame, where applicable.

Grounding electrode conductors shall be without splice and shall be contained within steel raceways and bonded to the raceway at both ends. Raceway may be omitted only where specifically indicated on the drawings.

A mechanical clamp type ground conductor connection is acceptable only if the connection is readily accessible for inspection and tightening. Any connection point not readily accessible shall be made by the thermal welding process.

The Contractor shall test the ground resistance of the completed grounding electrode system. If test indicates a resistance to ground in excess of 25 ohms it shall be reduced to 25 ohms or less by providing additional ground rods.

Prior to making the final main bond jumper connection from the grounding electrode conductor to the system neutral, the contractor shall demonstrate by megger test adequate isolation from ground of the system neutral. This test will

require that the system neutral be suitably isolated from service neutral if it has been grounded in any way.

The secondary of each Dry-Type Transformer and the output of each Generator and UPS whose neutral is not solidly connected to the service neutral are considered to be Separately Derived Systems.

The Grounding Electrode Conductor for the neutral and equipment of each Separately Derived System shall be connected to the nearest accessible member of the grounded structural metal building frame where applicable; or, in the absence of suitable structural metal, to the nearest accessible cold water pipe. This connection shall remain accessible after construction is complete.

Grounding Electrode Conductors for Separately Derived Systems shall be without splice and shall be contained within steel raceways and bonded to the raceway at both ends. Raceway may be omitted only where specifically indicated on the drawings.

Boxes

Boxes shall be of zinc coated steel or cast ferrous alloy as manufactured by Steel City, Raco, Crouse-Hinds, Appleton, or approved equal.

for exposed work on the exterior of the building, and in damp or wet interior locations, boxes shall be of cast metal with threaded conduit hubs and gasketed covers; or of zinc coated sheet steel of NEC gauge and size with screw fastened gasketed covers and threaded conduits hubs of zinc coated malleable iron and no knockouts or extraneous openings. Cover screws shall be stainless steel.

for exposed work in interior dry locations less than 8 feet above a floor or platform in other than Electrical, Mechanical or Communications Closets or Equipment Rooms, boxes shall be of cast metal with threaded conduit hubs and matching covers; or of zinc coated sheet steel of NEC gauge and size with screw fastened covers and no knockouts or extraneous openings. Cover screws shall be steel.

for exposed work in interior dry locations in Electrical, Mechanical, or Communications Closets or Equipment Rooms; or, in other dry areas, 8 feet or more above a floor or platform, boxes 5" square and larger shall be NEC gauge and size of zinc coated sheet steel. 4" octagonal, 4" square and 4-11/16" square "knockout" boxes shall be of zinc coated steel, NEC gauge and size. Box extensions are not permitted on exposed "knockout" boxes, and covers shall be of the raised surface type. "Handy" boxes are not permitted.

for concealed work, fixture outlet boxes shall be 4" octagonal minimum, provided with plaster rings in plastered surfaces. Concrete ring boxes shall be

ELECTRICAL GUIDELINES

used in poured concrete. Switch and outlet boxes in plastered and dry walls shall be 4" square minimum or one-piece multi-gang with appropriate plaster rings. Switch and outlet boxes in exposed brick, block or tile walls shall be single or multi-gang one-piece boxes not less than 3-1/2" deep with square corners and with internal device mounting holes, equal to Steel City Type GW. Boxes in walls finished with ceramic tile or wood paneling shall be 4" square minimum or one-piece multi-gang boxes, fitted with appropriate tile rings having square corners and internal device mounting holes. Ganged boxes are not permitted.

Floor boxes shall be cast-iron, approved for use on grade and above grade floors. The boxes shall be 14-1/2" L x 11-7/8" W x 3-7/16" H. There shall be four independent wiring compartments that allow capacity for up to four duplex receptacles and/or communication services. The floor boxes shall permit tunneling from adjacent or opposite compartments. Two of the four compartments shall have a minimum wiring capacity of 27 cu. in. and two compartments shall have a minimum wiring capacity of 36 cu. in. The boxes shall provide the following number of conduit hubs: four 1" and four 1-1/4". The boxes shall be fully adjustable, providing a maximum of 1-7/8" pre-pour adjustment, and a maximum of 3/4" after-pour adjustment. Activation covers shall be manufactured of die-cast aluminum with a brushed aluminum finish. Activation covers shall be available in flanged and flangeless versions. Covers shall be available with options for tile or carpet inserts, flush covers, or covers with one 1" trade size screw plug opening and one combination 1-1/4" and 2" trade size screw plug openings for furniture feed applications. Flanged covers shall be 7 3/4" L x 6-9/16" W. Flangeless covers shall be 6-3/4" L x 5-9/16" W. The boxes shall provide a series of device mounting communication plates that will accept both duplex power devices, as well as plates that will accommodate outlets and modular inserts. Wiremold RFB4-CI-1 or equal.

Wall receptacle, data, and telephone outlets shall be installed vertical, 18" up.

Outlets indicated as "counter height," as well as boxes for wall switches, fire alarm manual stations, and wall telephones shall be installed vertical, 46" up, clear of wall cabinets, back-splashes, and wainscot interferences.

Fire alarm signal devices shall be installed with the top of the device approximately 6" below the ceiling or with the bottom of the device 80" above the floor, whichever is lower.

Television signal outlets shall, unless otherwise indicated, be installed vertical, 84" up.

Switch boxes beside doors shall be on the strike side, with edge approximately

2" from door jamb or trim.

Junction and pull boxes may be used as necessary to facilitate wiring provided they are hidden from sight (but accessible), or installed in locations where exposed wiring is permitted, or flush mounted at locations approved by the Architect/Engineer.

Wiring Devices

Wiring devices and device plates shall be manufactured by Hubbell, Bryant, Arrow Hart, Pass and Seymour, Leviton, or Eagle.

Catalog numbers of one or more of the manufacturers are used herein and on the drawings to set a standard of quality and capacity. Equivalent products of the other named manufacturers are also acceptable, provided they are submitted and approved in accordance with Section 16010, Electrical General Requirements.

All wiring devices of any one general type (e.g. all duplex receptacles or all light switches) shall be of the same manufacturer, and shall match throughout.

Wiring devices shall be industrial specification grade.

Unless otherwise directed, wiring devices shall be gray in color.

Plates for flush outlets shall be stainless steel (type 302) and shall be standard size. Those for surface cast boxes shall be of steel, of shape and finish to match the box. Screws shall be steel to match the plate.

Each wiring device (including each switch) shall be equipped with a Hex-Head green grounding screw for grounding the device and plate to the outlet box and to the equipment grounding conductor run with the circuit conductors. "Self-Grounding" type mounting screws will not be accepted as the device grounding method.

Switches used for lighting control shall be listed to Fed Spec W-A-896E and rated 20 amps, 120-277 VAC, side wired, Hubbell 1221 series.

Switches used for disconnecting small single-phase motors and appliances shall be listed to Fed Spec W-S-896E and rated 20 or 30 amps to match the branch circuit rating and comply with their horsepower ratings, 120-277 VAC, side wired, Hubbell 1221 and 3031 series.

Weatherproof switches shall be equipped with stainless steel covers UL listed for wet locations with cover closed, Pass and Seymour WP-1.

Key operated switches shall be Hubbell 1221-L series.

Switches with collars around the operating toggle will not be accepted.

Receptacles shall be listed to UL498 and Fed Spec W-C-596. Unless otherwise indicated or required, receptacles shall be the duplex type, side and back wired,

ELECTRICAL GUIDELINES

with nylon face. On circuits supplying two or more such receptacles, they shall be rated 15 amps, 125 volts, NEMA 5-15R. Duplex receptacles on individual circuits shall be rated 20 amps, 125 volts, NEMA 5-20R.

Provide Hubbell 5262 and 5362 series for 5-15R and 5-20R respectively. Provide Ground Fault Circuit Interrupter receptacles, Hubbell GF5262 and GF5362 series for 5-15R and 5-20R respectively. GFCI receptacles shall be Class A, listed to UL standard 943. Provide Isolated Ground Receptacles, Hubbell IG5262 and IG5362 series for 5-15R and 5-20R respectively.

Provide weatherproof receptacles consisting of Ground Fault Circuit Interrupter receptacles as specified above with stainless steel covers UL listed for wet locations with cover closed, Pass and Seymour CA2-GH.

Devices shall be mounted tightly to boxes and be adjusted plumb and level. Devices shall be mounted flush with its associated coverplate. Ears on flush devices shall be in uniform contact with wall surfaces, or the devices shall be fitted with Caddy RLC device levelers. Device plates shall not be used for support of flush devices.

Where two or more devices are indicated for gang installation, they shall be trimmed with gang type plates.

Grounding type receptacles shall be grounded with insulated copper grounding conductors routed with the circuit conductors.

The Contractor shall provide suitable testers, and demonstrate, when directed, that receptacles are operational and correctly wired; and that ground fault circuit interrupter type receptacles will trip when current to ground has a value in the range of 4 through 6 milliamperes.

Raceway and Outlet Systems

Wall outlets shall consist of standard 4" x 4" x 2-1/2" outlet boxes with single device rings. Trim plates shall be blank to match wiring device trim plates.

Where requested by the Owner, cable tray shall be the aluminum ladder type with an inside width of 12 inches or 18 inches as is indicated on the drawings. On all trays, side-rail height shall be 5 inches with a loading depth of 4 inches. Rung spacing shall be 12 inches. Side-rails, rings and splice plates shall be of aluminum alloy 6063-T6. Tray loading capacity shall meet NEMA class 12B with a safety factor of 1.5. Tray shall comply with the requirements of NEMA VE1. Provide all necessary fittings, curbed sections, splice plates, hardware and accessories as required for a proper installation as shown on the drawings. At each point where the tray is not continuous including penetrations through firewalls, transitions to a different tray size, etc., equipment ground bonding jumpers sized

ELECTRICAL GUIDELINES

and in accordance with NEC 250, shall be installed. Cable tray systems require specific approval by the Owner.

Equipment boards shall be of size noted or shown on the drawings, and shall be constructed of 3/4" plywood, with finish grade on front. Paint board with gray fire-retardant paint.

Contractor shall fully coordinate with the telephone and system installer, and shall install service entrance raceways, backboards, and grounding conductors in accordance with their requirements.

Contractor shall fully coordinate with other installers of wiring and equipment and shall install raceways, outlets, cabinets, and backboards in accordance with their requirements.

Install pull boxes as necessary to limit runs between pull points to two 90 degree bends (or equivalent) and to 100 feet in length, unless other arrangements are approved by the wiring installers.

Leave all raceways with 100 lb. test nylon pull cord.

Unless specifically noted otherwise, provide an individual 1" conduit from each indicated outlet to the nearest cable tray, equipment cabinet or terminal board for the system involved.

Provide all conduits not terminating on boxes with plastic bushings.

At the equipment terminal board, terminate all conduits with plastic bushings.

Motor Controllers

Motor controllers for single-phase, fractional horsepower motors shall be 20 A, AC rated toggle switch.

Individual and grouped (motor control center) combination motor controllers shall have thermal magnetic circuit breakers for disconnecting means.

for pump and fan drive motors 5 HP and above, controllers shall be the variable frequency drive type. Refer to the Variable Frequency Drive section under Heating, Ventilation and Air Conditioning for VFD requirements.

for three-phase squirrel cage induction motors less than 5 HP, controllers shall be the magnetic type. Controllers shall include an encapsulated magnet coil, auxiliary contacts, line and load terminal connectors and a solid-state overload relay and sized for the actual nameplate current and service factor of the motor supplied. The magnet coil assembly shall be capable of operating satisfactorily with voltages within 85% to 110% of the voltage rating. The contacts shall be non-corroding, non-welding silver alloy contacts. Motor controllers shall be provided with two normally open and one normally closed auxiliary

ELECTRICAL GUIDELINES

contacts (in addition to holding circuit contacts) unless otherwise indicated.

Push buttons, selector switches, pilot lights, and remote push button stations shall be provided as scheduled on drawings or as indicated by the applicable control diagrams. If not indicated on drawings, provide at a minimum a hand-off-auto selector switch and a push-to-test red pilot light for each motor controller. Unless otherwise indicated, pushbutton stations and other control devices shall be the oil-tight heavy duty type. Pilot lights shall be long life type rated 7500 hours minimum. Provide Owner with two spare pilot lights of each size and type used.

Motor controllers shall be provided with integral control transformer with primary and secondary fusing.

Three-phase motor controllers shall be as manufactured by Allen-Bradley, Cutler Hammer, Seimens, Square D, or equivalent as accepted by the A-E.

Miscellaneous Devices

Time switches for the control of tungsten-lamps loads, fluorescent -lamp loads, resistive heating loads, motors and magnetically operated devices shall consist of a digital programmable timer and switch assembly in a suitable enclosure, as indicated and herein specified. Battery reserve power shall be provided which will automatically operate the timer in case of electric power failure for a period of not less than 30 days. Time switches shall be manufactured by tork, Sangamo, General Electric, or approved equal.

Fixture mounted photocell control devices shall include a snap-action switch with a rating of not less than 1000 watts incandescent load and 1200 volt-amp reactive or HID load at rated voltage and frequency. Device also shall have an inherent time delay in excess of 5 seconds, built-in surge protection, and the appropriate lock type receptacle base. The device shall be enclosed in a weatherproof enclosure. Individually mounted photo-control devices shall have the same characteristics as fixture mounted devices, except that they shall be field adjustable for "ON" "OFF" operation from 2 to 50 foot-candles, have a capacity of up to 2000 watts of incandescent load, be outlet box mounted, and not require surge protection. Photo-control devices shall be as manufactured by tork, Sangamo, General Electric, or approved equal.

Wall box dimmers shall be flush mounted, with built-in push-push switch and rotary dimming control, or sliding knob. Dimmers shall be continuously rated for AC (60 hz) loads of wattage as shown on drawing, except that no single dimmer rating shall be less than 1000 watts. Dimmers required at the same location shall be ganged. The Contractor shall provide dimmers that once ganged

ELECTRICAL GUIDELINES

shall be capable of handling the rating in watts indicated on drawings. Dimmers shall be Lutron NF series or equivalent.

Digital time switch shall be programmable to turn lights off after a preset time. Time switch shall be a completely self-contained control system. Time switch shall be compatible with all electronic ballasts, motor loads, compact fluorescent and inductive loads. Time scroll feature shall allow manual overriding of the preset time-out period. Time switch shall have the option for a one second light flash warning at five minutes before the timer runs out and twice when the countdown reaches one minute (when used to control lighting loads). Time switch shall have the option for a beep warning that shall sound every five seconds once the time switch countdown reaches one minute. Time switch shall have manual feature for timer reset where pressing the ON/OFF switch for more than 2 seconds resets the timer to the programmed time-out period. Time switch shall have an electroluminescent backlit Liquid Crystal Display that shows the timer's countdown. Time-out period shall be adjustable increments of 5 minutes from 5 minutes to 1 hour, and in increments of 15 minutes from 1 hour to 12 hours. Time switch shall be capable of operating as an ON/OFF switch. The time switch shall have a 100% OFF override switch with no leakage current to the load. In the event there is an open circuit in the AC line such as a ballast or lamp failure, the time switch shall automatically switch to OFF mode. Time switch shall have 5 year warranty and shall be UL and CUL listed.

Occupancy sensors shall be the dual technology type suitable for sensing both passive infrared and ultrasonic wave type, complete with a self-contained power/switch unit to avoid the need for low-voltage wiring to a remote sensor. Each sensor shall have a time delay circuit adjustable from 6 - 30 minutes with a shortened 30 second time delay feature for set-up purposes and a manual time delay bypass feature. In addition, each sensor shall have a LED walk test indicator for set-up purposes. The power/switch pack shall consist of a control transformer and rectifier circuit and a relay with contacts rated 277 VAC, 20 Amp, 4800 Watts. Provide spare set of contacts for connection to Building Management System. Upon detection of the heat waves or motion, the relay contacts shall instantly close to activate the room lighting. The contacts shall remain closed until no motion or presence of waves is sensed for the full length of time set by the adjustable time delay circuit. The sensor shall be ceiling mounted and located as recommended by the manufacturer. The sensor shall be provided complete with all necessary hardware, brackets, special boxes and covers.

ELECTRICAL GUIDELINES

Pad-Mounted Distribution Transformer

Pad-mounted mineral oil insulated transformer: Primary: 12,470Y/7200V; 95 kV BIL;

65 degrees C temperature rise, self-cooled.

Transformer shall be constructed to comply with ANSI C57.12.26.

Transformer shall be equipped with six high-voltage bushings in a “vee” configuration - three bushings to be reserved for “future” use and capped with appropriate molded rubber insulating caps to allow for future extension or the installation of elbow-type surge arresters.

Transformer shall be equipped with four low-voltage bushings arranged in a staggered configuration. Provide spades having four sets of NEMA two-hole lug positions for 750 kVA and larger transformers; and two sets of positions for 500 kVA and smaller sizes.

Xo bushing shall be equipped with a tank bonding strap.

Transformer shall be furnished with high-voltage under-oil primary switches to switch feeder “A”, feeder “B”, and the transformer radial feed. Switches shall be suitable for operation under load.

H₁(A,B), H₂(A,B), and H₃(A,B) shall be equipped with standard 200 A deep well equipment bushings and 200 A bushing inserts to connect to 200 A molded load break elbow connectors conforming to IEEE/ANSI Standard 386.

Tank shall be fitted with six parking stands to accept 200 A insulating bushing standoff accessory immediately adjacent to the 200 A bushings per ANSI C57.12.26.

Connection shall be grounded wye - grounded wye.

Impedance shall be approximately 5.75%.

Taps shall be provided on the high voltage side at 13090, 12780, 12160, and 11850 volts.

Enclosure shall be provided with both padlocked handle and penta-head captive bolt provisions.

Enclosure to be finished in a Munsell Green 37.0GY 3.29/15 or equivalent.

Transformers shall be provided by approved vendors - currently approved vendors are Square D, Cooper, and ABB. Other vendors may be considered if requested specifically by Contractor.

Provide 8’ ground rod within transformer pad for bonding of metal cabinet and system neutrals.

Provide a ground ring of #2 stranded soft drawn bare copper to include the ground rod and the tank grounding lug of the transformer. Ring shall conform closely to the tank wall and the perimeter of the cable compartment of the

ELECTRICAL GUIDELINES

enclosure and shall completely loop the primary and secondary cable entrance areas if physically possible.

Neutrals of all primary cables shall be bonded to the #2 ground ring from the grounding adapter connections at the elbow terminations using #2 stranded soft drawn bare copper - ground leads shall be trained so as not to interfere with the normal operation of the elbows during connection or disconnection.

One strand of the concentric neutral shall be separated from the remainder and looped through the static relief eye in each elbow.

Primary cables to be trained such that the elbows can be moved from the HV bushings with a “shotgun stick” while energized and parked in the provided parking stands without the use of the hands on the cable and without fouling the grounding connections from the elbow to the ground ring.

No bushing of the transformer shall be connected to the ground ring with a #2 bare copper conductor.

Provide one 1” SCH40 PVC conduit from secondary compartment of pad-mounted transformer to the side of the transformer or the building wall (by Owner permission) for metering installation.

All medium voltage transformers shall be clearly labeled “DANGER - HIGH VOLTAGE - IF FOUND OPEN OR UNLOCKED, REPORT AT ONCE TO UNIVERSITY PHYSICAL FACILITIES DEPARTMENT” or “DANGER -HIGH VOLTAGE” if for vault type gear in an area accessible only to qualified personnel.

Any equipment not immediately adjacent to its means of disconnection shall be clearly labeled to indicate where the disconnect switch is located.

Marking to be accomplished using metallic or non-metallic placards with permanently applied lettering. Outdoor applications shall employ UV resistant materials.

Pad-Mounted Loop Interrupter Switchgear

Refer to the latest version of WFU High Voltage Distribution System Standards and Specifications, Section 16340, for information on Loop Interrupter Switchgear. Contact WFU Facilities for this document.

Medium Voltage Cable

Refer to the latest version of WFU High Voltage Distribution System Standards and Specifications, Section 16121, for information on medium voltage cable. Contact WFU Facilities for this document.

Medium Voltage Cable Splicing and Termination

ELECTRICAL GUIDELINES

Refer to the latest version of WFU High Voltage Distribution System Standards and Specifications, Section 16232, for information on Medium Voltage Cable Termination and Splicing. Contact WFU Facilities for this document.

Medium Voltage Surge Arresters – Elbow Interface

Refer to the latest version of WFU High Voltage Distribution System Standards and Specifications, Section 16480, for information on Medium Voltage Surge Arresters, Elbow Interface. Contact WFU Facilities for this document.

Electrical Duct Bank System

Duct Bank System shall consist of single, round bore conduits encased in concrete. The minimum number and size of ducts shall be as indicated on the drawings. Duct lines shall be laid to a minimum continuous slope of 4 inches per 100 feet with slope directed away from any electrical equipment and toward manholes. Duct lines shall contain no depressed sections that would prevent proper drainage of duct to adjacent manhole. Changes in direction of runs exceeding 10 degrees shall be accomplished by using special couplings or bends manufactured for this purpose. Duct lines shall be installed so that the top of concrete or future concrete as shown is not less than 36" below finished grade or finished paving at any point. Where duct lines enter manholes, hand holes or pull boxes, the conduits shall terminate in end bells.

Conduits shall be thoroughly cleaned before setting in place. During construction and after the duct line is completed, the ends of the conduits shall be plugged to prevent water from washing mud into the conduits. Particular care shall be taken to keep the conduits clean of concrete or any other substance during the course of construction. Where it is necessary to cut a tapered end on a piece of conduit at the site, the cut shall be made with a tool or lathe designed to cut a taper to match the taper of the particular conduit to be used.

After the duct line has been completed, a mandrel not less than 12" long, having a cross section approximately $\frac{1}{4}$ " less than the inside cross section of the conduit shall be pulled through each conduit, after which a brush with stiff bristles shall be pulled through to make certain that no particles of earth, sand, or gravel have been left in the lines.

In an installation of duct bank comprised of multiple conduits, each single conduit shall be completely encased in concrete with a minimum of 3 inches between it and other conduits and a minimum thickness of concrete encasement of 3 inches. This encasement may be increased to fit the actual shape of the trench. Spacers for PVC conduits shall be Underground Devices, Inc. "Wunpeese" or

ELECTRICAL GUIDELINES

equal. Spacers shall not be spaced over 6 feet on center. Joints in a conduit shall be staggered at least 6" from joints in other conduits. Conduits shall be securely anchored to prevent movement during the placement of concrete.

Installation of a single conduit shall be completely encased in concrete. The thickness of concrete shall be not less than 3" on the sides, bottom, and top of the conduit.

Conduits shall be Schedule 40 PVC as manufactured by Carlon or approved equal.

Concrete shall be plain except where reinforced concrete is specified herein or indicated on the drawings. Concrete shall be 2500 psi compressive strength with 3/8" diameter maximum aggregate size. Ducts shall be of monolithic construction. Where a connection is made to an existing duct line, the concrete encasement shall be well bonded to the existing encasement. Concrete shall contain a red dye on the top side of the duct bank.

All electrical duct banks shall contain reinforcing steel rebar run parallel with the ducts. The number, size and location of rebar shall be sufficient to allow a minimum ten foot span of undermined duct bank to be self-supporting. In no case shall any individual rebar be less than 3/8 inch in diameter. Tie wiring of sufficient size for holding the rebar in proper alignment shall be incorporated into the duct bank at appropriate spacing. The rebar "cage" shall be bonded to the electrical system ground in each manhole.

Duct Bank Installation

Where possible, cut trench so that sides of trench act as a form for the concrete encasement. Install ducts without "dips" on low points so that ducts will drain to manholes. All duct bends shall be made with minimum 10 foot radius. Pour concrete so as to fill all voids. Earth cover over duct bank must be minimum 36 inches. First 12 inches of backfill to be of compacted pit run gravel and sand. All underground duct bank shall have metalized warning tape installed above the duct bank that identifies the specific system buried below. The warning tape shall consist of a minimum 3.5 mil solid foil core encased in a protective plastic jacket (total thickness 5.5 mils). Tape shall be 6 inches wide with black lettering imprinted on a color coded background that conforms to APWA color code specifications. Tape shall be installed 18 inches above the duct bank and in no case less than 6 inches below grade.

Trenching and Backfilling

The Contractor shall furnish all labor, equipment, appliances and materials,

ELECTRICAL GUIDELINES

and perform all operations related to the trenching and backfilling for electrical conduit systems. The Contractor shall perform all excavation of every description and of whatever substances encountered, to the depths specified or indicated on the contract drawings. All excavated materials not required for fill or backfill shall be removed and wasted as directed. All excavations shall be made by open cut. The banks of trenches shall be kept as nearly vertical as practicable and where required shall be properly sheeted and braced.

The bottom of duct trenches shall be accurately graded to provide uniform grade of 4" per 100' minimum. Any over depth excavation shall be filled with sand, gravel, or concrete, at the expense of the Contractor. The depth of the duct trench shall be determined by the finished grade and the minimum depth of the duct bank and obstructions.

All grading in the vicinity of trench excavations shall be controlled to prevent surface groundwater from flowing into the trenches. Any water accumulated in the trenches shall be removed by pumping or by other approved methods. During excavation, material suitable for backfilling shall be stacked in an orderly manner, a sufficient distance back from edges of trenches to avoid overloading and prevent slides or cave-ins. Material unsuitable for backfilling shall be wasted as directed.

All shoring and sheeting required to perform and protect the excavation and to safeguard employees shall be performed in accordance with the published standards of the N. C. Department of Labor.

The trenches shall be carefully backfilled with excavated materials approved for backfilling that are free from large clods of earth or stones. Blasted rock, broken concrete or pavement and large boulders shall not be used as backfill material. Settling the backfill with water will be permissible or required when so directed. Any trenches improperly backfilled or where settlement occurs, shall be reopened to the depth required for proper compaction, then refilled and compacted with the surface restored to the required grade and compaction, mounded over and smoothed off.

Backfill in open areas shall be compacted to at least 95% of maximum density. Backfill under paved areas shall be compacted to at least 95% of maximum density, with the top layer of at least 6" compacted to at least 97% of maximum density at, or near, optimum moisture, as determined by the AASHTO T-180 Method D.

Existing pavement cut or damaged shall be patched by a qualified subcontractor in accordance with the requirements of the A-E.

Maximum density shall be as specified herein. A minimum of one density test shall be performed on every 100 ft. of trench or section thereof and one for each manhole and hand hole excavation. Submit to the Engineer a written report

ELECTRICAL GUIDELINES

of each density test performed. If, in opinion of the engineer and based on reports of the testing service or inspection, the compaction is below the specified density, additional compaction and testing shall be provided with no additional expense to the Owner.

All spaces between perimeters of window and door frames and adjacent construction and other materials built into exterior walls and all other voids and spaces between construction materials in exterior walls where exterior air would infiltrate into the building shall be packed tight with fiberglass batt thermal insulation.

Install faced insulation with vapor barrier facing toward the interior of the building.

Follow written recommendations of the manufacturer of insulation and of fasteners for method of attaching insulation. In addition to the manufacturer's recommendations, comply with the following procedure to prevent wall insulation from sagging and leaving non-insulated space at top of the wall. Lap edges of insulation over metal studs. Tape the first lap to the metal stud and tape the second lap to the first lap.

Butt ends and edges of insulation batts together and tape for a continuous sealed installation. Split and cut insulation as required to fit around pipe, boxes, etc. Where possible, make continuous behind such objects by overlapping insulation.

Provide impaling clips, wire lattice or UL approved plastic netting to support insulation in vertical or horizontal position and to prevent tearing and sagging as required by construction conditions.

Electrical Metering Devices

Refer to the latest version of WFU High Voltage Distribution System Standards and Specifications, Section 16492, for information on Metering Devices. Contact WFU Facilities for this document.

Secondary Distribution Equipment

Distribution equipment, other than fuses, shall be manufactured by Square D, Siemens, or Cutler-Hammer. Equipment design features and components indicated on the drawings are those of Cutler-Hammer, and the standard construction features of that manufacturer shall be considered as minimum requirements, with additional requirements as specified herein and on the drawings.

Fuses shall be manufactured by Bussmann, Gould Shawmut, or Littelfuse.

Circuit breakers shall be provided as the over-current protection devices for

ELECTRICAL GUIDELINES

services, separately derived systems, feeders, and branch circuits. Fuses may be used only where indicated on the drawings, or required by the nameplate for equipment connected, or specified herein.

Molded-case and insulated-case circuit breakers shall be the static or thermal-magnetic type, quick-make and quick-break for manual and automatic operation. Multi-pole breakers shall be common trip. Circuit breakers shall be bolted in place unless specifically approved by the Owner in advance. Thermal-magnetic breakers shall be calibrated at 40 degrees C or ambient compensated. Ampere ratings, frame sizes, and short circuit ratings shall be as indicated on the drawings. Series ratings may be applied only where specifically indicated on the drawings. Individual enclosures shall be NEMA 1 indoors, 3R outdoors, unless otherwise indicated. Other circuit breakers shall be suitable for installation in Switchboards, Panelboards and Motor Control Centers as hereinafter specified.

Single-pole 15 and 20 amp circuit breakers shall be SWD rated.

Fuses shall be the non-renewable, time delay, cartridge type, UL Class RK5 unless otherwise indicated; for installation in Safety Switches, as hereinafter specified.

Fusible switches shall be incorporated into Safety Switches, as hereinafter specified. Manual operation shall be quick-make and quick-break. Fuse holders shall be the Class R rejection type unless otherwise indicated.

Safety switches shall be the NEMA heavy duty type, horsepower rated, with interlocked covers that can be defeated, non-fusible except where fused switches are indicated or fuses are required. Switch mechanisms shall be quick-make and quick-break. Enclosures shall be NEMA 1 indoors, NEMA 3R outdoors unless otherwise indicated. Fuse holders, where required, shall be as specified above for fusible switches. Switch shall have provisions for padlocking switch handle open or closed.

Enclosed circuit breakers shall be enclosed in U.L. listed enclosures, NEMA 1 indoors and NEMA 3R outdoors unless otherwise indicated.

Circuit breaker handle shall be accessible from outside enclosure with cover closed.

Enclosure shall have provisions for padlocking circuit breaker handle open or closed.

Group mounted circuit breakers in Panelboards and Switchboards shall be provided with nameplates as described above; or they shall be identified with numerals and cardboard directories in metal or heavy polycarbonate, directory frames. Directories in metal frames shall be protected with rigid plastic covers.

ELECTRICAL GUIDELINES

Directories shall be sized to permit all circuit designations to be read without removing the card from the frame.

Manufacturer's nameplates or labels on custom fabricated or factory assembled custom equipment shall contain sufficient identification to expedite the future procurement of parts, additions, and shop drawings.

Service Equipment shall be UL labeled as "Suitable for use as Service Equipment." Service disconnects shall be clearly identified.

Floor mounted equipment such as Switchboards, Motor Control Centers, and Dry-Type Transformers shall be provided with 4" high concrete pads and shall be secured to the concrete pad. Pads shall have a 3/4 inch chamber on each accessible side.

Exterior Safety Switches that are readily accessible to unauthorized persons shall have their covers padlocked closed by the Contractor. Keys shall be identified and delivered to the Owner.

Upon completion of the project, furnish to the Owner one complete set of replacement fuses, consisting of three fuses of each type and rating used.

Directory cards for Panelboards and for group mounted Switchboard sections shall be neatly filled-in with a typewriter to indicate the type and location of the load on each circuit or feeder.

Surge Protection Device System (SPD)

Operating Temperature range shall be 40 to +50 C (40 to +122 F)

Operation shall be reliable in an environment with 0% to 95% non condensing, relative humidity.

The SPD maximum continuous operating voltage shall be greater than 115% of the nominal system operating voltage to ensure the ability of the system to withstand temporary RMS overvoltage (swell) conditions.

Protection Modes: All Modes: L N, L L, L G, (N G where applicable). Note: L = Line, N = Neutral, G = Ground

The SPD shall have a minimum UL 1449 3rd Edition Nominal Discharge Current Rating (In) of 10,000 Amps. When used in conjunction with a UL 96A certified Lightning Protection System the (In) rating shall be 20,000 Amps.

UL 1449 3rd Edition listed, bearing the official UL 3rd Edition gold hologram label.

UL 1283 5th Edition listed.

The Surge Protective Device (SPD) shall be a stand-alone configuration. Systems that must be integral to the switchgear will not be considered.

All SPD systems shall be permanently connected, parallel designs. Series

ELECTRICAL GUIDELINES

suppression elements shall not be acceptable.

The SPD shall be marked with a Short Circuit Current Rating (SCCR).

SPD designs that limit the 100% rated surge protection shall not be acceptable.

Hybrid design utilizing:

Thermally Protected Metal Oxide Varistors

Filter capacitors to suppress EMI/RFI electrical noise.

Modular Surge Protection for Service Entrance/Main Distribution and Critical Equipment Applications

Modes of Protection: The SPD system shall provide surge protection in all possible modes (L-N, L-G, L-L, and N-G). Each replaceable module shall provide the uncompromising ability to deliver full surge current rating per mode.

SPD modules shall be configured to isolate individual suppression component failures without causing total loss of surge protection in that mode.

Opening of supplementary protective devices, internal or external, shall not be permissible during UL 1449 3rd Edition Nominal Discharge testing.

Optional Connection Methods: Terminal Block, 60A #6AWG.

Each individual module shall feature a green LED indicating the individual module has all surge protection devices active. If any module is taken off-line, the green LED will turn off and a red LED will illuminate, providing individual module as well as total system status indication.

Provide with Solid State Status Indication Lights.

The modular SPD shall be provided in a NEMA 12 or 4X enclosure.

The SPD shall provide EMI/RFI electrical noise attenuation of 36 to 44dB in the range of 50kHz to 100MHz as defined by MIL-STD-220A test procedures.

Voltage Protection Ratings: The UL 1449 3rd Edition Voltage Protection Ratings “VPR” (6kV, 3000 Amps, 8/20µs waveform) shall not exceed the UL assigned values listed below.

Approved Manufacturers: The following SPD manufacturers and respective models shall be deemed acceptable, subject to conformance with indicated requirements:

THOR SYSTEMS	TSr Product Series
Current Technologies	SL2 Produce Series
Liebert	Interceptor II Series

A modular SPD shall be close-nipped to the distribution panel and shall be supplied by a 60 Amp circuit breaker. The installing contractor shall connect the SPD in parallel to the power source, keeping conductors as short and straight as

ELECTRICAL GUIDELINES

practically possible. The contractor shall twist the SPD input conductors together to reduce input conductor impedance.

Non-Modular Surge Protection for Distribution, Sub-Distribution and Branch Circuit Panels

All non-modular units shall be factory wired using color coded #10AWG Rope Lay ultra-low resistance wire (413 strands of 36 AWG, seven groups of 59 strands each): two feet maximum length for each phase conductor and three feet maximum length for Neutral and Ground conductors.

The non-modular SPD shall be provided in a compact NEMA 4X polycarbonate enclosure with a CELAR cover.

The SPD shall provide EMI/RFI electrical noise attenuation up to 35dB in the range of 50kHz to 100MHz as defined by MIL-STD-220A test procedures.

Voltage Protection Ratings: The let-through voltage test results used to obtain the UL 1449 3rd Edition Voltage Performance Ratings “VPR” (6kV, 3000 Amps, 8/20µs waveform) shall not exceed the UL assigned values listed below.

Approved Manufacturers: The following NON-MODULAR SPD manufacturers and respective models shall be deemed acceptable, subject to conformance with indicated requirements:

THOR SYSTEMS	TSn Product Series (50 to 150kA/Mode)
Current Technologies	TG Product Series (50 to 150kA/Mode)
Liebert	Accuvar AII Product Series (up to 80kA/Mode)
	LM Product Series (100 to 150kA/Mode)

A non-modular SPD shall be close nipped to the panelboard and shall be supplied by a 30 Amp circuit breaker. The installing contractor shall connect the SPD in parallel to the power source, keeping conductors as short and straight as practically possible. The contractor shall twist the SPD input conductors together to reduce input conductor impedance.

Switchboards

Switchboard construction shall comply with NEMA Standard PB2 and UL 891.

Switchboard enclosure shall be NEMA standard, type as indicated on drawings. Enclosure shall be finished with a medium light gray, standard with manufacturer both exterior and interior surfaces. All sheet metal parts shall be rust-proofed after fabrication, prior to painting.

Framework shall consist of code gauge steel rigidly welded and/or bolted

ELECTRICAL GUIDELINES

together to support all cover plates, bus way, and component devices. Steel used for framework shall be zinc coated or otherwise treated to resist corrosion.

Each section shall have an open bottom and an individual removable top plate for installation and termination of conduits.

Switchboard current ratings shall be as indicated in switchboard schedule on drawings.

Bus-way shall be of silver plated copper sized to match the feeder ampacity and braced for 65,000 amperes short-circuit current unless otherwise indicated. Bus-way shall be designed for connection to adjacent equipment and/or for future extension where so indicated on the drawings. A copper ground bus shall be fastened to the structure and shall extend for the full length of the switchboard.

Provide a painted “mimic” bus on front of switchboard enclosure to depict actual bus arrangement inside.

All busses, switching devices and connections shall be of sufficient size to limit the temperature rise to UL standards and all bus surfaces shall be corrosion resisting conductive plated surfaces. All bus connections shall be bolted. All busses shall be braced for short circuit stresses of not less than the fault values scheduled on drawings.

Separate neutral and equipment ground busses sized at 100% and 25% of phase busses respectively, unless otherwise noted, shall be provided for the full length of the switchboard. Connections other than on load side of over-current devices shall be by means of rigid bus and not cable. Lugs shall be provided on neutral and ground busses suitable for terminating all circuit conductors individually.

Furnish all necessary bus-way, straps, brackets, hardware and removable blank covers.

Metering section shall be separated from the rest of the switchboard by insulated or metal barriers.

Rear accessible switchboard shall be totally enclosed, self-supporting dead front distribution type with required vertical sections in which the over-current protective devices are individually mounted and the lug connections are accessible from the rear.

The top and side covers shall be removable with covers bolted to the frame. Formed sheet steel front and rear doors and end panels, adequately flanged to ensure stiffness, shall enclose the switchboard. Front and rear doors shall be equipped with hinges with removable pins and shall be held closed by two or more knurled and slot head captive screws. All metal barriers, sides, top, ends

and fronts shall not be less than code gauge steel plate.

Over-current protective devices shall be:

Main device-air circuit breakers (UL1066)

Feeder devices - molded case circuit breakers (UL489)

All bus-way shall be accessible for inspection and maintenance purposes from ends and rear after removing cover plates and opening doors. Line busses and load terminals shall be located such that reaching across or beyond a line bus to make load connections is not necessary.

All switchboard sections shall have full height barriers.

Feeder circuit breakers shall be individually mounted.

Circuit breakers shall be the thermal-magnetic type. Where specifically indicated, circuit breakers shall be the electronic trip type utilizing solid-state circuiting to initiate the tripping action. Current sensing shall utilize digital sampling techniques and be true RMS with an error of less than 1% with load distortion of up to the 13th harmonic. Adjustments on electronic trip circuit breakers shall include a long time current setting, short-time pickup, and ground-fault delay. Other features shall include a rating plug, instantaneous trip and a ground fault trip indicator. Circuit breakers rated at 1000 amperes or larger shall also provide for adjustable long time delay, short time delay instantaneous pickup and ground-fault pickup. Provide system monitoring and diagnostics on circuit breaker where indicated on the drawings. Provide circuit breaker interface module.

Provide a digital line Meter Monitor and Protection device having the features and functions specified below. The meter shall consist of a single microprocessor-based unit capable of monitoring and displaying the functions listed below with the accuracy indicated; the meter shall auto range between units, kilounits and megaunits. The meter shall provide the adjustable protection functions indicated and the capability to communicate data via twisted pair network. The meter shall be UL listed, CUL and CE certified and also meet ANSI standard C37.90.1 for surge withstand.

ELECTRICAL GUIDELINES

Metered Values (Accuracy % Full Scale)	Alarm Functions
AC Phase Amperes +/- (0.3%)	Voltage Phase Loss (less than 50% rms)
AC Phase Voltage +/- (0.3%)	Current Phase Loss (1/16 Largest phase)
Watts +/- (0.6%)	Phase Voltage Unbalance (5 to 40% - 5% steps)
VA +/- (0.6%)	Phase Voltage Reversal
VAR +/- (0.6%)	Overvoltage (105 to 140% - 5% steps)
Power Factor 1.0% (+/- 1 digit)	Undervoltage (95 to 60% - 5% steps)
Frequency +/- (0.1 Hz)	Time Delay for Overvoltage, Undervoltage, and Phase Unbalance (0 to 20 seconds – 1-sec. steps)
Watt hours +/- (0.6%)	
VAR hours +/- (0.6)	
VA hours +/- (0.6%)	
Watt Demand with 10-, 15-, 20-, 25-, 30-, 45-, 60-minute interval	
% THD (through 31 st harmonic)	
Voltage – minimum/maximum	
Current – minimum/maximum	
Power – minimum/maximum	
Power Factor – minimum/maximum	
Frequency – minimum/maximum	
Peak % THD	
Peak Demand	

Input ranges of the meter shall accommodate external current transformers with ranges from 5/5 through 12,800/5 amperes. Provide external current transformers with rating as indicated on the drawing or sized for incoming service. Potential transformers shall be self included and fused up to 600 volts.

Control power shall be capable of being supplied from the monitored incoming AC line without the need for a separate AC supply control circuit or separate remote power source (96 to 264 AC or 100 to 350V DC).

Make provisions for an addressable communication card capable of transmitting all data, including trip data over a compatible two-wire local area network to a central personal computer for storage and/or printout. The network shall also be capable of transmitting data in RS-232c format via a translator module.

In switchboard sections specified to include insulating barriers or insulated bus-way, all phase terminals, lugs, and connections that remain un-insulated

ELECTRICAL GUIDELINES

after installation shall be carefully taped with high temperature insulating tape.

Switchboard shall be set on a 4 inch high poured concrete pad which extends approximately 2 inches beyond the switchboard on all sides. Pad shall have 3/4 inch chamfer on each accessible side.

Panelboards

Branch panelboards shall be built to NEMA Standard PB-1, UL Standards UL50 and UL67, and NEC requirements.

Branch panelboard back boxes shall be constructed of galvanized sheet steel and shall be securely fabricated with screws, bolts, rivets, or by welding. Back boxes shall be a minimum 20" wide and 5-3/4" deep, unless noted otherwise, and heights shall not exceed 72" overall. top or bottom gutter space shall be increased 6" where feeder loops through panel. End plates shall be supplied without knockouts.

Branch panelboard covers shall be constructed of high grade flat sheet steel with door-in-door construction. The inside hinge door shall allow access to device handles only. Door shall close flush with cover and against a full inside trim stop. Hinges shall be inside type. The outer hinged door shall allow access to wiring gutter. A flush latch and tumbler type lock, so panel door may be held closed without being locked. All such locks shall be keyed alike. Furnish to the Owner two keys with each lock, or a total of 10 keys for the project. Four or more cover fasteners of a type which will permit mounting plumb on box. Cover shall also have inside support studs to rest on lower edge of the back box while being fastened. for flush mounted panelboards, cover fastening hardware shall be concealed behind the hinged door. A means shall be provided for readily adjusting projection of panel interior assembly with all connections in place. A method requiring stacking of washers is not acceptable. Interior trim shall fit neatly between interior assembly and cover leaving no gaps between the two.

Branch panelboard phase and neutral bus shall be copper. A copper ground bus shall be provided in each panel. Minimum short circuit rating of any panelboard assembly shall be 10,000A. Furnish panelboards with higher rating where so noted or where evidently intended by specification of circuit breakers with higher interrupting capacity. Ampacity of mains shall be equal to, or greater than, the ampacity of the feeder unless otherwise indicated.

In spaces for addition of future circuit breakers furnish all necessary bus-way, strap, brackets, hardware, and removable blank covers. Breakers in branch panelboards shall be physically arranged in locations shown in panel schedules on the drawings where possible. Circuits shall be connected to the phases as shown.

ELECTRICAL GUIDELINES

Branch panelboard circuit breakers shall be of the bolt-on type.

Panelboards rated 400 amperes and greater shall be Distribution Type.

Distribution panelboard shall be NEMA PB 1, circuit breaker type and shall be Square D Company I-Line construction or equal.

Distribution Panelboard Bus shall be copper. One continuous fully-rated bus bar per phase with ratings as indicated. Provide copper ground bus and copper neutral in each panelboard equipped with lugs to accommodate all conductors to be connected. Unless otherwise noted, the neutral bus rating shall be 100% of phase bus rating and the ground bus shall be a minimum of 25% of phase bus rating. Where more than one ground bar is furnished, each ground bar will be interconnected with a conductor sized not less than the panelboard feeder ground conductor. Ground bar shall be bonded to enclosure.

Distribution panelboard interior trim shall be dead front construction. Main lugs shall be mounted in the mains compartment. Main circuit breaker and main lug interiors shall be field convertible for top or bottom incoming feed. Enclosure shall be Type 1 unless otherwise indicated on drawings and compliant with UL 50. The operating handle of the top most mounted device shall be no higher than 6 feet 6 inches above the finished floor. Back-box shall be constructed without pre-punched knockouts.

Distribution panelboard cabinet front shall be a four piece surface trim for surface mount standard. Where specifically indicated on the drawings, either a single hinged door or door-in-door construction shall be provided. For door-in-door construction, the inner hinged door shall allow access to the device handles only and the outer hinged door shall allow access to wiring gutter. Enclosure and front shall be either galvanized steel or stainless steel and shall be finished in manufacturer's standard gray enamel. The enclosure shall be minimum 26 inches wide.

Panelboard RMS symmetrical interrupting capacity shall be minimum 22,000 amperes unless otherwise indicated on drawings. Molded Case Circuit Breakers shall comply with NEMA AB 1 and UL 489. Circuit breakers shall provide positive indication of ON, OFF, and tripped conditions. All breakers shall be quick-make, quick-break. Multi-pole breakers shall be common-trip, resulting in all poles opening simultaneously under trip conditions.

Equipment shall be installed perfectly plumb and level. Openings in back boxes shall be cut or sawed with tools made for that purpose. Unused openings shall be closed. Only one solid wire is allowable under a screw. Provide approved lugs for connecting stranded wire or more than one solid conductor. Panelboard back-boxes shall be mounted with their tops 6'-8" above the floor. Centered

above the breakers in each panelboard attach a nameplate indicating panel designation - for example "PANEL A", or "PANEL MDP".

Motor Control Centers

The construction of the Motor Control Centers shall comply with the requirements of UL Standard UL-845, NEMA Publication ICS-2-322, and the National Electrical Code. Each vertical section and each compartment shall be UL listed and so labeled.

Motor Control Center shall be constructed in sections approximately 20 inches wide and 20 inches deep, and shall be designed so that matching sections can be added at either end of the unit. Each section shall provide 6 units of vertical mounting space (nominal 12 inches per unit).

Minimum 6 inch horizontal wire-ways shall be provided at the top and bottom of each section. Vertical wire-ways shall be provided at the right-hand side of each section. Wire-ways shall be isolated from the bus bars.

Bus-way shall be silver plated copper. Bus bar ratings shall be as noted on the drawings. If not otherwise noted, horizontal buses shall be rated 600A, vertical buses 300A, and bracing shall be for 42,000 amps. A copper ground bus shall be provided at the bottom front, and shall run the entire length of the Motor Control Center.

Motor Control Centers shall be furnished with NEMA Class 1 Type B wiring, with separable control wiring terminal blocks mounted in the starter unit compartments or in the adjacent vertical wire-ways.

Provisions shall be made for future extension of the horizontal busses at either end with standard splice plates.

Units furnished shall consist of combination motor controllers, feeder circuit breakers, fused switches or other devices as indicated on the drawings.

Dry Type Building Transformers

Unless otherwise indicated, 3-phase transformer primary voltages shall be 480V "delta", and secondary voltages shall be 120/208V, 4 wire "wye".

Enclosures shall be ventilated for indoor use unless otherwise indicated.

Transformers shall be designed for floor or platform mounting, however they shall be provided with wall mounting brackets where wall mounting is indicated on the drawings.

Windings shall be of copper or aluminum. Windings shall be designed for full load operation at a maximum temperature rise of 115 degrees C above a 40 degrees C ambient; however winding insulation shall be rated 220 degrees C.

ELECTRICAL GUIDELINES

Each transformer shall be provided with FCBN taps on the primary winding of the manufacturer's standard percentages, but not less than four 2.5% FCBN taps.

Core and coil assemblies shall be mounted on rubber isolation pads to minimize transmission of sound and vibration. Sound levels for individual transformers, measured in accordance with NEMA standards, shall not exceed 45 decibels for sizes 225 KVA and smaller and 50 decibels for sizes larger than 225 KVA.

Transformers indicated to be the non-linear type shall, in addition, be suitable for use on distribution systems supplying loads which generate 3rd, 5th, 7th, 11th and 13th harmonic currents. These are typical non-linear loads such as computers. Non-linear type transformers shall have a full length copper electrostatic shield which produces an average affective coupling capacitance of 30 picofarads between primary and secondary. Electrical noise attenuation shall average 120 dB common mode and 30 dB normal mode. Non-linear type transformers shall have the neutral bar sized for at least 200% ampacity of the secondary phase conductors, shall have a "K" rating of K-13, designed for use with 100% non-linear switching loads and shall be UL 1561 listed.

for floor mounted units, provide 4" high poured concrete pads. Provide vibration isolating pads under frame supports.

Where feasible, conduits shall enter the enclosures of floor mounted transformers from underneath.

Where conduits must attach to transformer housing, utilize 12" lengths of flexible conduit terminated with connectors and bonding bushings.

Transformer enclosures and secondary neutrals shall be grounded as Separately Derived Systems.

Each unit shall bear manufacturer's nameplate indicating transformer rating and connection diagram.

Provide nameplate indicating transformer designation, voltage, and device from which transformer is supplied.

Lighting Fixtures and Accessories

LED lighting will typically be utilized as the project's basis of design. Linear and compact fluorescent lighting may be considered as an alternate to LED lighting. H.I.D and Incandescent lighting should only be considered for a project by specific approval of the Owner.

All fixtures shall be labeled by Underwriters' Laboratories, Inc.

Recessed incandescent and H.I.D. fixtures shall be equipped with automatic

reset thermal protection.

Pendant Fixtures shall be equipped with swivel hangers; twin stem for individual fluorescent fixtures and single stem for continuous row fluorescent fixtures, spaced according to the manufacturer's recommendations but not less than one per fixture unit plus one per row.

Recessed fixtures in plaster and gypsum board ceilings shall be equipped with plaster frames. In other ceilings they shall be equipped with plaster frames and/or other devices as approved by the Architect/Engineer, to facilitate removal of fixture and access to the concealed junction box.

Plastic materials indicated to be "acrylic" shall be of 100% virgin methyl methacrylate produced by Rohm and Haas, DuPont, or Cyanimid.

Eight-foot chassis with lamps in tandem may be used in lieu of four-foot fluorescent units in continuous rows, except where recessed into ceiling construction which incorporates exposed support members at four-foot intervals.

Recessed Fluorescent Fixtures (Troffers) shall conform to the following minimum requirements unless modified by notes and schedules on the Drawings:

Housings shall be of 4-3/8" minimum, 5" maximum depth, and of 22 gauge minimum steel, with deeply formed transverse ribs for rigidity, primed, and finished in baked white enamel. The use of pre-painted steel is acceptable.

Lenses shall be of flat clear K-12 type acrylic of .125" nominal (.115" minimum) thickness in rigid hinged steel or extruded aluminum door frames finished in baked white enamel and secured with inconspicuous spring-loaded or rotary cam type steel latches. Lenses shall be maintained in a flat position with invisible clips, and shall be removable from the door frames using a screwdriver without damaging the lens or the frame.

Joints between housings and door frames shall be totally free of light leaks. Gaskets, if used, shall be invisible and in compression when the door is closed. Gasket material subjected to rubbing when the door is opened or closed will not be accepted. Flexible and/or removable black baffles will not be accepted.

Ballasts shall be as hereinafter specified. Lamp holders shall be rigidly mounted and replaceable without removing the fixture from the ceiling. Lamp holder wiring shall not be exposed in the lamp compartment.

top access plates to facilitate wiring are optional for the Contractor. Each fixture shall be individually connected to a concealed junction box with #16 TFN conductors in 6 feet of 3/8" flexible metal conduit.

Troffers for inverted tee exposed grid ceilings shall be designed to be raised through the ceiling opening, and be supported and framed by the ceiling tees.

ELECTRICAL GUIDELINES

They shall be secured to the ceiling grid with four “earthquake clips” furnished by the fixture manufacturer.

Troffers for plaster and gypsum board ceilings shall be furnished with plaster frames.

Troffers for ceilings with concealed suspension systems including plaster, gypsum board, and acoustical tile shall be equipped with suitable adjustable yokes or brackets designed to hook onto the plaster frame or ceiling channels, prevent the channels from spreading, and support the fixture.

Fixtures shall be a regularly cataloged and commonly manufactured product of an established, recognized lighting fixture manufacturer, with published photometric data and Zonal Cavity Coefficients of Utilization based on tests conducted by an independent photometric testing laboratory. Tests and calculations shall be in accordance with current IES standards.

Fluorescent fixtures containing three or more lamps shall be ballasted and connected to permit separate switching of center lamp in three-lamp units, two center lamps in four-lamp units.

Metal halide fixtures shall be enclosed.

A disconnecting means shall be provided as a part of the UL listed fixture package for all fluorescent ballasted fixtures that will disconnect simultaneously from the source of supply all conductors of each ballast including the ground conductor as required by NEC 410.73(G).

Lamps

Lamps shall be manufactured by Osram Sylvania, General Electric, or Philips.

Nominal 4-foot “Building Standard” fluorescent lamps shall be the 28 watt, T8 instant start type or rapid start type, fully compatible with the ballasts supplied.

High Intensity Discharge (H.I.D.) lamps shall be selected to conform to the lighting fixture manufacturer’s recommendations for base type and direction, bulb shape and coating, and compatibility with the ballast supplied.

Ballasts

Ballasts for fluorescent and H.I.D. lamps shall be manufactured by Advance, Jefferson, Magnetek, or approved equal. All fixtures of the same type shall be supplied with ballasts of the same manufacturer.

Fluorescent and H.I.D. ballasts shall be High Power Factor, UL listed and labeled, and designed for operation at 120 or 277 volts as applicable, unless oth-

erwise indicated.

H.I.D. ballasts, unless otherwise indicated, shall be the high reactance or Constant Wattage type.

Electronic fluorescent ballasts shall be Class P with Ballast Efficacy Factors in compliance with NAECA Requirements. Electronic ballasts shall provide high frequency operation with lamp current crest factors of 1.7 or less and total harmonic distortion of less than 20%. Light output and noise levels shall comply with CBM standards for equivalent electromagnetic ballasts.

Ballasts for 28 watt fluorescent lamps shall be Rapid Start or instant start as indicated. Program start ballasts are required for lamps controlled by an occupancy sensor. Preheat ballasts shall be provided for compact fluorescent lamps and for straight lamps less than 14 watts.

Fluorescent Ballasts shall be two-lamp wherever possible and one-lamp where necessary. Three and four-lamp ballasts may be provided only where specifically indicated on the drawings.

for dimming of linear fluorescent lamps, dimming ballasts shall have a power factor greater than 0.95 and a lamp current crest factor (CCF) less than or equal to 1.7 as specified in ANSI C82.11. Dimming ballasts shall be a programmed rapid start type and preheat lamp cathodes before applying full arc voltage to ensure average rated lamp life is not diminished. Dimming ballasts shall provide end-of-lamp-life protection for T5 linear and T4 and T5 4-pin lamps.

Dimming ballasts shall be capable of striking lamps at any light level without first flashing to full light.

for dimming of T4 compact fluorescent and T5 biax fluorescent lamps, dimming ballasts shall have a continuous flicker-free dimming range of 5-100% relative light output. Electronic dimming ballast shall have a ballast factor greater than 0.95 and total harmonic distortion (THD) rating of less than 10% at full light output. Dimming ballasts shall utilize 0-10 volt dimming technology for dimming control. Dimming ballasts shall be Lutron Compact SE 5% or equal.

Led Drives

Provide ten-year operational life while operating at maximum case temperature and 90 percent non-condensing relative humidity. Drives shall be designed and tested to withstand electrostatic discharges up to 15,000 V without impairment per IEC801-2. Electrolytic capacitors shall operate at least 20 degrees C below the capacitor's maximum temperature rating when the driver is under fully-loaded conditions and under maximum case temperature.

Drives shall have a maximum inrush current of 2 amperes at 120V and 277V.

ELECTRICAL GUIDELINES

Drives shall withstand up to a 4,000 volt surge without impairment of performance as defined by ANSI C62.41 Category A. Drives shall be manufactured in a facility that employs ESD reduction practices in compliance with ANSI/ESD S20.20.

Drives must have a Class A Sound Rating, inaudible in a 27 dBA ambient. Drives must have no visible change in light output with a variation of plus/minus 10 percent line voltage input.

total Harmonic Distortion must be less than 20 percent and meet the ANSI C82.11 maximum allowable THD requirements.

Drives must track evenly across multiple fixtures all light levels.

Constant current drives must provide models to support from 200mA to 2.1 Amps (in 10mA steps) to ensure a compatible driver exists and support LED arrays up to 40W or 50W (710mA to 1.05A in 10mA steps).

Constant voltage drives must provide models to support from 10V to 40V (in 0.5V steps) to ensure a compatible driver exists and support LED arrays up to 40W.

3-Wire Drive Control shall have continuous dimming from 100 percent to 1 percent relative light output. Provide integral fault protection to prevent driver failure in the event of an input mis-wire.

Digitally Addressable Control shall have continuous dimming from 100 percent to 1 percent relative light output. Each driver shall respond independently to up to 32 occupant sensors and to digital load shed command.

forward Phase Control (Neutral Wire Required) shall have continuous dimming from 100 percent to 1 percent relative light output.

LED 0-10V drives shall have a Class A sound rating and a minimum operating ambient temperature of -40°C . The drives shall have a life expectancy of 50,000 hours at T_{case} of $\leq 70^{\circ}\text{C}$ and a life expectancy of 100,000 hours at T_{case} of $\leq 62^{\circ}\text{C}$. It shall have a maximum self rise of 25°C in open air without heat sink. The drives maximum allowable case temperature is 75°C . The drives must reduce output power to LEDs if maximum allowable case temperature is exceeded. The drives must tolerate sustained open circuit and short circuit output conditions without damage.

Emergency Exit Luminaire

Emergency exit luminaires shall be completely self-contained, provided with maintenance-free battery, automatic charger, and other features. Luminaires must be third-party listed as emergency lighting equipment, and meet or exceed the following standards; NEC, N.C. Building Code, Volume X Energy Code,

ELECTRICAL GUIDELINES

NFPA-101, and NEMA Standards. Battery shall be sealed, maintenance-free type, with minimum of 90 minutes operating endurance. Battery shall have a normal life expectancy of 10 years. Batteries shall be high temperature type with an operating range of 0 degree C to 60 degrees C and contain a re-sealable pressure vent, a sintered + positive terminal and – negative terminal. Charger shall be fully automatic solid-state type, full-wave rectifying, with current limiting. Charger shall restore the battery to its full charge within 24 hours after a discharge of 90 minutes under full rated load. The unit shall be activated with the voltage drops below 80 percent. A low voltage disconnect switch shall be included if LEAD Battery is used, to disconnect the battery from the load and prevent damage from a deep discharge during extended power outage. Pilot light shall indicate the unit is connected to AC power. The battery shall have high rate charge pilot light, unless self-diagnostic type. Tests switch shall simulate the operation of the unit upon loss of A.C. power by energizing the lamps from the battery. This simulation must also exercise the transfer relay. The entire unit shall be warranted for three years. The battery must have an additional two more years' pro-rated warranty. Warranty shall start from the date of project final acceptance. Warranty shall be included in the contract document. The use of LED is required due to their reliable performance, low power consumption, and limited maintenance requirements. Maximum LED failure rate shall be 25% within a seven (7) year period; otherwise, if exceeded, manufacturer shall replace the complete unit at no charge to the owner.

Emergency Egress Luminaire

Emergency egress luminaires shall be completely self-contained, provided with maintenance-free 12 volt battery, automatic charger, two lamps, and other features. Luminaire shall be third-party listed as emergency lighting equipment, and meet or exceed the following standards: NEC, N.C. Building Code, Volume X Energy Code, NFPA-101, and NEMA Standards. Pilot light shall indicate the unit is connected to A.C. power. The battery shall have high rate charge pilot light, unless self-diagnostic type. A test switch shall simulate the operation of the unit upon loss of A.C. power by energizing the lamps from the battery. This simulation must also exercise the transfer relay. If fluorescent emergency unit is used, an LED charging indicator light must be easily visible after installation and a remote test switch shall be installed adjacent to the fixture. Battery shall be sealed, maintenance free type, with minimum of 90 minutes operating endurance. Battery shall have a normal life expectancy of 10 years. Batteries shall be a high temperature type with an operating range of 0 degree C to 60 degrees C and

ELECTRICAL GUIDELINES

contain a re-sealable pressure vent, a sintered + positive terminal and – negative terminal. Charges shall be fully automatic solid state type, full wave rectifying, with current limiting. Charger shall restore the battery to its full charge within 24 hours after a discharge of 90 minutes under full rated load. The unit shall be activated when the voltage drops below 80%. A low voltage disconnect switch shall be included if LEAD battery is used, to disconnect the battery from the load and prevent damage from a deep discharge during extended power outage. The entire unit shall be warranted for three years. The battery must have an additional two more years' pro-rated warranty. Warranty shall start from the date of project final acceptance. Warranty shall be included in the contract document.

Light Fixture Installation

Lighting fixtures shall be supported from the building structure using corrosion resistant steel hardware. Ten gauge minimum steel wire may be used for support from the structure where concealed above suspended ceilings.

In addition to the supports from the structure, fixtures shall also be secured to suspended ceilings on which they are mounted, or in which they are recessed. Where fixtures are secured to suspended ceilings, the primary supports from the building structure shall be slack.

A minimum of two No. 12 gauge wire supports attached to the structure shall be provided for each lighting fixture unless otherwise indicated or approved by the Architect/Engineer. The supports shall be located at diagonal corners of rectangular fixtures and angled away from fixture. A minimum of three full twists shall be made at each end to secure wire.

Where installed recessed in grid type ceilings, attach each fluorescent fixture to the grid with a minimum of four "earthquake clips" furnished by the Lighting Fixture manufacturer.

Conductors in fixture taps shall be #16 AWG minimum, type TFN, in 3/8" flexible metal conduit of 72" maximum length. A green insulated equipment grounding conductor shall be included.

Where parabolic louver type fluorescent fixtures are to be furnished, the fixture louvers shall remain plastic-wrapped until project is completed.

High Intensity Discharge lamps that fail during the 12 month guarantee period will be considered to have been defective and shall be replaced by the Contractor at no cost to the Owner.

for each tandem-wired fluorescent troffer fixture, provide "pointer" decal to indicate paired complement fixture. Adhesive decal shall be no less than one inch wide by two inches long and shall be black. Decal shall be affixed to the

ballast cover and shall only be visible when the lens or louver door is opened.

Low Voltage Switching Systems

Low-voltage switching systems shall be manufactured by Watt Stopper, MicroLite, ILC Enercon, touch-Plate or an approved equal.

Modular Relay Panels shall be UL listed and consist of the following:

Empty NEMA 1 enclosure that can accept an interior sized to accept up to 12, 24, or 48 mechanically latching relays.

Power supply assembly shall utilize two 40VA transformers with separate secondaries. Transformers shall have internal over-current protection with automatic reset and metal oxide varistor protection against power line spikes.

Interiors shall be provided with up to 12, 24, or 48 installed and tested relays, bracket and intelligence board backplane. Panel shall be provided with an integral DIN rail mounting bar for easy installation of other system components (such as a time clock and/or photocell controller). Terminals shall be included in the interior to accept a data-line for the connection of data-line switches to the system, or to allow a data-line to be run between multiple panels for network communications.

Eight channels for grouping relays shall be provided in each interior regardless of size, each with an associated pushbutton to toggle the channel ON/OFF, and a terminal block for a separate dry contact input. Any number of relays in the panel can be assigned to each channel, with overlapping allowed. Each channel pushbutton shall provide LED status indication: RED shall indicate that all relays within the channel group are ON; NO LED shall indicate that all relays within the group are OFF, and GREEN shall indicate the channel's relays are in a MIXED state (some OFF, some ON).

Relays shall be momentary-pulsed mechanically latching contactors with plug in connector and 30 VAC Isolated contacts for status feedback and pilot light indication.

Coil shall be magnetically-held, momentary coil activation (50 milliseconds) with 20 amp contacts that are tungsten and NEMA electronic ballast rated for 50,000 ON/OFF cycles at full load and standard 1 year warranty.

Next to each relay shall be an individual override button and a bi-color LED to indicate status.

Panels shall support the "blink warning" function, with LED indication for each relay.

Each channel button's dry control contact input terminal shall accept either 2 or 3-wire, maintained or momentary inputs. They shall also accept a 2-wire

ELECTRICAL GUIDELINES

toggling input.

Provide a Group Switching card (GS) that allows simple group and pattern configuration at the panel without requiring handheld devices or special programming tools. The GS shall allow any group of relays within the panel to be associated to a channel button.

HARDWARE FEATURES

Each GS card will support up to eight groups (channels). The 8-relay and 24-relay panels shall support one GS card; the 48 relay panels will support two cards.

Individual relays may be assigned to more than one channel, and the channel status will be annunciated appropriately.

Each channel shall also have an input for connecting switch or dry contacts for controlling a channel. Inputs shall accept 2 or 3-wire, maintained or momentary inputs, or a 24 VDC signal from occupancy sensor or other voltage signaling device. Groups may be controlled by: an on-board group pushbutton switch, low voltage switch, dataline switch, occupancy sensor, photocell, or time of day.

Screwless, removable, plug-in terminals will be provided for all low voltage wiring connections.

Provide an advanced communications network that supports optional features like PC connectivity, TCP/IP connections, advanced programming system documentation, enhanced diagnostics, historical and runtime accumulation, and graphic programming and control.

The system shall support the following advanced operating scenarios:

Adjustable override periods for after hour use based upon the day of the week.

Preemptive override before OFF to prevent blink warning and to start a new override time delay.

Allow common areas to remain ON when specific relays in a panel are ON. Egress timer starts a countdown when the last watched relay turns OFF.

Master Switch Control with blink option shall provide a blink warning and five minute countdown for Occupants when a master switch is turned OFF.

Interior day-lighting control shall turn OFF lights when available natural light meets occupants' lighting needs. Lights shall only come on during occupied periods when enough natural light is not available.

Occupancy Sensor Integration: Allows relays to automatically follow occupancy sensors' status, or interlock the sensors with daily schedules (Relays stay

ELECTRICAL GUIDELINES

ON during scheduled ON time, and follow sensors only during after-hours period).

COMMUNICATIONS

Each panel shall support RS232, proprietary twisted pair and optional RS-485 connections. Either protocol may be used for programming, monitoring, and control. The dataline shall allow simultaneous operation of multiple communications access points to support multiple operator terminals and communications with other building automation systems.

Each panel shall be capable of stand-alone automatic operation and the network shall achieve full distributed processing.

All programming shall be accomplished with a Windows based PC running compatible software package.

HARDWARE FEATURES

Each communication control card shall be capable of providing all logic, control, runtime data, status information, and communications functions for up to 48 relays in a panel.

EEPROM power loss memory and clock and holdup time: 30 days.

Provide automatic self-diagnostics on all memory, input/output card modules, relays and data-line.

Provide digital clock with time, day of week, and date and automatic leap year compensation. Provide programmable Daylight Savings Time and Standard Time adjustment.

WINCONTROL SOFTWARE

SCHEDULES

Each communication control card shall support up to 24 unique weekly schedules out of a total of 1,000 available per system. Each schedule shall allow up to eight events per day for a repeating seven day week.

Up to 32 holidays may be defined for any specific date. On that date any of the three holiday schedules may be assigned.

Relays may be programmed to switch to a different weekly schedule on any specific data, and then revert back to normal at another time. This allows for future schedule changes to be programmed ahead of time.

“Spring Ahead” and “Fall Back” dates for daylight savings time changes may be entered full two years ahead. Software also support the ability to “Auto fill”

ELECTRICAL GUIDELINES

in the next two occurrences of each of these dates.

TIME DELAY/BLINK WARNING

Used during unoccupied periods, assignable for each relay.

Time delays from 2 to 1,440 minutes.

Blink Warning: 1-second OFF blink followed by a 5 minute grace period before OFF.

Provide second blink warning one minute before OFF.

Operate automatically for all scheduled OFFs and time delay overrides.

TELEPHONE OVERRIDE

Each relay shall respond to up to eight different telephone override codes. Maximum of 9999 telephone codes can be programmed.

Runtime Counters for Each Relay

Provide cumulative runtime (up to 31 years) and number of cycles (up to 17 million) since last reset.

Provide daily runtime for the current day and each of the prior 40 days.

Provide monthly runtime for current and 14 prior months.

ACTIVITY LOGS

Store previously relay events including the time, new state, and cause for the change in state.

Annunciate over the data-line and RS232 port when the table is 25%, 50%, 75% and 100% full.

Analog Photocell Monitoring

Each group switching card will support up to eight analog photocell inputs. The analog inputs will allow the operator to establish light level set-points in foot-candles at which lighting will turn ON or OFF.

Actual foot-candle light levels may be read using the Operators Software.

All programming and editing may occur both online or offline in a WIN/NT 32-bit application specific program. Data shall be entered through a simple menu-driven software package.

The software shall simplify integration with other software products by allowing the lighting control manufacturer's components to be embedded into other Windows applications.

from the lighting control system software database, the software shall be able to automatically create a system single line drawings, panel schedules and specifications that can be exported in DXF format for use in standard CAD drawings.

A data-line access port will provide monitoring, programming and control of the system.

The desktop computer must be a Intel Core 2 Duo (minimum 2.0 GHz clock speed) class personal computer with monitor for HDMI graphics display, minimum, 19" LCD color monitor with minimum native resolution of 1280 X 1024, 500 GB hard drive, 4 GB RAM, minimum six USB ports, CD+R/+W drive, Microsoft Windows 7 Operating System and Lighting control software, WinXP Pro.

A network appliance will provide multi-user, simultaneous access to the lighting system using standard TCP/IP and the Win Control software specified.

Color graphics software, WinControl Graphics, shall allow a user to monitor and control the low voltage relays through a graphical color interface. The system will allow the user to create drawings through a graphics generator provided with the system. The system will control the relays in a real-time environment; i.e. all system changes will be communicated immediately through the color graphic screens.

Low voltage switches shall provide a momentary signal to allow individual relay control or group control using the Group Switching card. Switches shall be available in 1-button, 3-button, 5-button, or 9-button designs. The 1, 3, and 5 switch devices shall mount in a standard single gang box; the 9-switch version in a two-gang box. Each switch shall use an LED pilot light for the individual buttons to indicate status of the controlled relay or group of relays.

Manufacturer shall provide a 1 year warranty for all system components.

Engine-Generator System

Upon failure of the normal power source to any Automatic Transfer Switch, the system shall function automatically to restore power to designated loads from the Engine-Generator set. Acceptable manufacturers for the engine-generator system are Cummins-Onan, Kohler, Detroit Diesel, Generac and Caterpillar. The Engine-Generator set assembler shall be the prime manufacturer of either the diesel engine or the generator. The manufacturer shall maintain, within 100 miles of the site, a qualified parts and service organization with personnel factory trained to diagnose and repair the engine and the generator.

Rating of the emergency generator set shall be based on operation of the set when equipped with all necessary operating accessories such as air cleaners, lubricating oil pump, fuel transfer pump, fuel injection pumps, jacket water pump, governor, alternating current generator, exciter, radiator fan, and supercharger, if used. The set shall be rated as indicated on the drawings for continuous

ELECTRICAL GUIDELINES

stand-by service; however, the rating shall not exceed 115% of the manufacturer's published "prime power" rating with all accessories included.

All materials and parts comprising the units herein specified shall be new and unused, of current manufacture, and of the highest grade, free from all defects or imperfections affecting performance. It is the intent of these specifications to secure a diesel electric generator set which can be properly maintained and serviced without the necessity of the purchaser carrying expensive parts stock, or being subjected to the inconvenience of long periods of interrupted service due to lack of available parts. The manufacturer shall maintain permanent parts depots from which the parts may be obtained in necessary quantities at any time.

The diesel engine shall operate satisfactorily on a commercial grade of no.2 diesel oil and shall be of the vertical, multi-cylinder, two or four cycle, solid injection full diesel type, with moving parts housed. The maximum speed of the engine in the service anticipated shall not exceed 1800 RPM. The lubrication system shall be of the forced type. The cylinder liners of the engine shall be removable. The crankshaft shall be fully counterbalanced with all bearing surfaced to case-hardened or equal. There shall be one more main bearing than there are number of cylinders for an engine or pairs of cylinders for a V-engine. The complete diesel engine generator unit shall be free from critical and torsional vibration within the operating speed range. The fuel injection system for the engine shall be of the low pressure type with the pressure in the single rail to all injectors not to exceed 300 PSI. Each engine shall be furnished with the following accessories: full flow oil filter, dry type air filter, replaceable element fuel filter, electronic governor to maintain engine speed within 3% from no load to full load, engine mounted fan and radiator with duct flange for cooling in 100 degree F. ambient temperature, a battery charging generator and regulator with a capacity of at least 20 amps, and one or more jacket water heaters, thermostatically controlled to maintain coolant temperature at 90 degrees F. shall also be provided.

The alternator shall be designed and built in accordance with applicable NEMA and IEEE Standards. The alternator shall be rated no less than the KW required @ 125 degrees C. The alternator rating shall be suitable to start the fire pump with a wye-delta controller with the total building emergency load connected with no more than 15% voltage dip at the alternator terminals. The alternator rating shall be suitable to start the fire pump across the line with total building emergency load connected with no more than 35% voltage dip at the alternator terminals. The generator shall be a brushless type, voltage and frequency regulated, 0.8 power factor rated, drip-proof machine. Insulation shall

be NEMA Class “B” or “F” and maximum temperature rise at continuous operation under the rated load shall not exceed the NEMA standard rise for the particular class of insulation. The generator shall have a direct connected exciter and double sealed, pre-lubricated ball bearings. Voltage regulation shall be within +2% of rated voltage from no load to full load.

Control panels shall be mounted on or adjacent to the generator and shall be completely assembled and wired by the manufacturer in a NEMA 1A enclosure. The panel shall include a lube oil pressure gauge, water temperature gauge, engine hour meter, lube oil temperature gauge and an ammeter for battery charging generator.

Provide a minimum of two 12 volt batteries in series (24 volts) of sufficient capacity for the ambient requirements of the installation and a 60 second continuous cranking period, but not less than 200 ampere-hours each. Batteries shall be rack or tray mounted on or adjacent to the engine-generator.

Provide a wall mounted high-low rate battery charger for each unit, complete with DC voltmeter and ammeter, and high-rate signal light. High rate output shall be 10 amps. La Marche A46 or approved equal.

A Maxim or approved equal critical exhaust silencer shall be furnished with each engine. The silencers shall be designed for horizontal mounting and shall be suspended from the overhead structure. A section of flexible exhaust pipe shall be provided for each engine exhaust outlet. All other exhaust piping shall be black iron of a size recommended by the engine manufacturer. Vertical sections of exhaust piping shall be fitted with suitable condensate traps with drain valves, and exhaust outlets shall be equipped with a flapper type rain caps.

The fuel supply system shall consist of a skid mounted fuel storage tank, fuel pump, and all necessary piping and accessories to ensure constant priming, immediate starting, and constant supply of fuel to the engines, all in strict accordance with NFPA Standard No. 30, the North Carolina State Building Code and the Environmental Protection Agency.

Each engine shall be equipped with a gear driven fuel pump.

Copper piping shall be used for supply and return lines between the fuel tank and the engine. Short lengths of flexible copper or brass tubing shall be used for the engine connections.

The skid mounted fuel storage tank shall be of double wall construction to provide secondary containment of fuel in event of a weld seam failure in the fuel storage section of the tank. Rupture basin section of tank shall be a minimum of 10% of the actual fuel tank capacity. Tank capacity shall be 500 gallons minimum.

ELECTRICAL GUIDELINES

The enclosure shall be 14 gauge formed construction, modular design, gasketed roof bolts, plush rain ledge on four sides. All bolts shall be 3/9" cadmium plated with lock washers. Hinges shall be continuous type with 1/4" brass pins.

The roof shall be flanged lap rain-tight construction, complete with roof stiffeners. The doors shall be full length piano hinged with fixed open air intake louvers, and equipped with adjustable plated pad-type latches and matched keys and rubber door stops.

There shall be sufficient doors on each side and on rear to gain easy access to all components of the set. Hinged radiator fill access door and radiator core guard, drip flange and gasketed exhaust exit shall be provided.

Complete enclosure shall be primed with two coats of zinc-chromate and finished and painted with two coats of enamel.

All doors and air intake louvers shall be equipped with plated pad-type latches and matched keys. Vents and louvers shall be screened.

The enclosure shall include all necessary battery racks and cables, lights, and suitable base. Enclosure shall be securely anchored to the base.

Exhaust piping need not be insulated inside enclosure or on enclosure roof, but "DANGER - HIGH TEMPERATURE EXHAUST" warning signs shall be provided. Signs shall be of a permanent type, of a sufficient number and located so as to alert both qualified and non-qualified persons.

for the Engine-Generator Set provide a raised concrete foundation as recommended by the Engine-Generator manufacturer. Provide spring-type vibration isolators and anchor bolts between the concrete foundation and the base of the Engine-Generator.

After installation of the complete unit, a 4-hour load performance test including 1/2 hour at full load and final adjustments shall be performed by, or under the direct supervision of, a factory trained service technician, provided by the manufacturer of the diesel Engine-Generator set. The contractor shall provide the necessary lube oil for the engine, and a permanent anti-freeze solution in the cooling system to protect from freezing to -20 degrees F. The contractor shall provide a load bank for the performance test of the Engine-Generator System. The Main Fuel Storage Tank shall be filled after the tests are successfully completed.

Automatic Transfer Switch

Upon failure of the normal power source to the Automatic Transfer Switch, the switch shall function automatically to restore power to designated loads from the Engine-Generator set.

Automatic transfer switches shall be manufactured by Russelectric, ASCO, Zenith, Onan or approved equal.

The Automatic Transfer Switch shall consist of a standardized assembly of switches and controls for the automatic transfer of loads from one source to another. The Automatic Transfer Switch features and controls shall be fully coordinated with the emergency generator.

The continuous ampere rating and voltage and pole configuration of the Transfer Switch shall be as required. The Transfer Switch shall have a 3-cycle short circuit withstand capability and closing rating equal to, or in excess of, the circuit breaker ahead of the normal input to the transfer switch as indicated on the drawings. The Transfer Switch shall be UL 1008 listed and labeled as “Automatic Transfer Switch for Emergency Systems”.

The Transfer Switch shall be electrically operated, mechanically held and interlocked both electrically and mechanically to positively prevent the connection of the load to both sources simultaneously or interconnection of the two sources. Components of the operating mechanism shall be insulated or electrically dead. Molded case circuit breaker mechanisms may be utilized in the Transfer Switch provided that they are not also used as over-current protective or manual disconnecting devices.

The transfer switch shall be equipped with a safe external manual operator designed to prevent injury to operating personnel. The manual operator shall provide the same contact to contact transfer speed as the electrical operator to prevent a flashover from switching the main contacts slowly. The external manual operator shall be safely operated from outside of the transfer switch enclosure while the enclosure door is closed.

The Transfer Switch shall automatically transfer its load to an emergency supply after failure of its normal supply. Upon restoration of the normal supply, the Transfer Switch shall automatically retransfer its load to the Normal supply. The Transfer Switch shall obtain its operating current from the source to which the load is being transferred. Transfer mechanisms shall be energized only momentarily during transfer, with momentary delay or in-phase monitors to avoid out-of-phase transfer of motor loads.

The transfer switch shall be equipped with a microprocessor based control system, to provide all the operational functions of the automatic transfer switch. The controller shall have two asynchronous serial ports. The controller shall have a real time clock with Ni-Cad battery back-up.

A load test switch shall be included to simulate a normal power failure, keypad initiated.

ELECTRICAL GUIDELINES

Light emitting diodes shall be mounted on the microprocessor panel to indicate switch is in normal position, switch is in emergency position and controller is running.

A plant exerciser shall be provided with (10) 7 day events; programmable for any day of the week and (24) calendar events, programmable for any month/day, to automatically exercise generating plant programmable in one minute increments. Also include selection of either “no load” (switch will not transfer) or “load” (switch will transfer) exercise period. Keypad initiated.

A three phase digital LCD voltage readout, with 1% accuracy shall display all three separate phase to phase voltages simultaneously, for both the normal and emergency source.

A digital LCD frequency readout with 1% accuracy shall display frequency for both normal and emergency source.

LCD readout shall display normal source and emergency source availability.

Lightning Protection System

System shall be certified by the installer to comply with the following minimum standards: National Electrical Code; NFPA 780, Lightning Protection Code; UL96 - Lightning Protection Components; and UL96A, Installation Requirements for Lightning Protection Systems.

System materials shall be Class I or Class II, as defined by NFPA 780.

System components shall be the standard product of an approved manufacturer where products have been in similar and satisfactory use for a period of not less than five (5) years. System components shall be as manufactured by Thompson Lightning Protection, Inc., Independent Protection Co., Inc., Robbins Lightning Protection Co., Inc., East Coast Lightning Protection Co., Inc. or approved equal. Main roof conductors and down lead conductors shall be of bare stranded copper cable. Air terminals shall be of solid bronze, with tapered points, not less than 3/8” diameter, 18” in height above adjacent building surface or as indicated on drawing. Ground ring shall be of bare stranded copper cable. Miscellaneous clamps, anchors, splice connectors, and bonding cables shall be of trade standard types, UL labeled for the application, and in accordance with the above referenced standards. Driven grounding electrodes shall consist of copper clad steel rods. Rods shall be 10 feet long and 3/4” diameter. In locations where system components are mounted on aluminum surfaces, aluminum materials shall be used to avoid electrolytic corrosion of the dissimilar metals.

Install roof conductors generally along ridge of each building section. Connect roof conductors to down lead conductors at an average interval not to exceed

100 feet. Connect roof conductors to structural steel columns at intervals not to exceed 100 feet. Cadweld or equivalent process shall be used for connections which are underground or which will become inaccessible when construction is complete. Cables used for down conductors shall be run in concealed conduits. Upon completion of the lightning protection system, the system shall receive a UL master label.

Fire Alarm System, Addressable

Equipment and materials shall be provided by a factory-authorized distributor to ensure proper specification adherence, final connection, test, turnover, warranty compliance, and service. The factory-authorized distributor is required to have been in the fire alarm industry (service and installation) for a minimum of 5 years.

Activation of any manual station, smoke detector, sprinkler system flow switch, or other alarm initiating device shall cause: the sounding of audible signals throughout the facility, the flashing of alarm indicating signal lights, indication of the alarm condition at the control panel indicating type of alarm (e.g. whether manual station, smoke detector, etc.) as well as location of initiating device, shut-down of air handling systems, closing of smoke dampers (power and controls) and other control functions as indicated or required.

The magnetic door holders shall be released only by the activation of their associated smoke detectors.

All strobes must be synchronized in common spaces.

Provide a horn silence function with an adjustable delay of 2 minutes to 15 minutes. Delay shall prevent silence function from engaging. Silence function shall be manually activated only and shall not prevent visual alarm from flashing. Provide a supervised “AHU Shutdown Defeat” switch in or adjacent to the FACP. This switch shall cause a system “trouble” indication when placed in the off-normal (shutdown defeated) position. This switch shall allow temporary resumption of HVAC operation in the event that an unwanted alarm will not clear.

The Fire Alarm System shall assume primary control of elevator operation when a smoke detector located in any associated elevator lobby, elevator machine room or elevator hoist way initiates. The Fire Alarm System shall signal shut-trip operation of elevator main power circuit breaker when a heat detector located in the associated elevator hoist way initiates.

The fire alarm system shall incorporate one way voice communications and tone generating capabilities. The one-way communications system shall be dual channel, allowing the transmission of an evacuation audio signal to one or more

ELECTRICAL GUIDELINES

zones and simultaneous manual voice paging to other zones selectively and in any combination.

Acceptable manufacturer is Simplex Grinnell 4010 or 4100ES.

The fire alarm control panel shall include all modules and components required for specified function, including, but not limited to: 24 VDC system power and supervisory control; style 6 (Class A) signaling line circuits providing individual identification of initiating devices, and individual operation of indicating appliances and control relays; style Y (Class B) notification appliance circuits; battery, charger, control, and metering. Batteries shall be lead-calcium sealed-cell type. Capacity shall be adequate to operate system for 24 hours minimum in standby, plus 5 minutes in alarm and modules and/or relays as required for special system functions. Control panel enclosure shall include spare space for a minimum of five additional modules.

The fire alarm system shall be microprocessor driven with stored program controllers. Each panel (node) on the network shall use a multiple microprocessor design so that the failure of a single microprocessor will not result in a local failure. Fire alarm systems that utilize only one microprocessor for system (node) and SLC control will not be accepted.

Each detector shall be capable of automatic electronic addressing and/or custom addressing and shall mount on a common base to allow the simple replacement of one detector type with another detector type. The addressing of the detectors will not depend on the electrical position of the detector on the circuit. If devices require DIP switches or rotary dials for addressing, every device shall be physically removed and verified during final checkout with engineer to confirm devices are located and programmed correctly. All of these devices and their bases will also be required to be labeled with engraved lexan labels to identify device address and intended location. Labels shall be red background with white letters; letters shall be a minimum of 1/4" in height.

Heat Detector shall have a solid state heat sensor, and shall transmit an alarm at a fixed temperature of 135° F (57°C) or due to a temperature Rate of Rise of 15°F/minute (9°C/minute). The detector shall continually monitor the temperature of the air in its surroundings to minimize thermal lag to the time required to process an alarm. The heat detector shall be rated for ceiling installation at 70 ft (21.3m) centers and be suitable for wall mount applications.

Photoelectric detector shall utilize a light scattering type photoelectric smoke sensor to detect visible particulates produced by combustion. The detector shall dynamically examine values from the sensor and initiate a system alarm based on the analysis of data. Detector shall continually monitor any changes in

sensitivity due to the environmental effects of dirt, smoke, temperature, aging and humidity.

Duct smoke detector shall utilize a photoelectric smoke detector that is readily adaptable for use in air duct smoke detection applications, using a housing that mounts to the outside of the duct. When used for duct smoke detection, the smoke detectors shall not forfeit any of the system functionality which they have when used as area smoke detectors. The duct smoke detection housing shall allow the detector to sample and compensate for, variations in duct air velocity between 300 and 4000 feet per minute. The detector sampling tube shall extend the full width of the duct. Sampling tubes longer than 36 inches shall be supported from ends. Remote alarm LEDs and Remote Test Stations shall be supported by the duct smoke detector and provided where indicated. All detectors used in duct applications shall be located in accordance with NFPA 72 recommendations.

The Fire Alarm System shall incorporate addressable modules for the monitoring and control of system Input and Output functions over a 2 wire electronic communications loop, using both broadcast and serial polling protocols. All modules shall display communications and alarm status via LED indicators. The function of each connected module shall be determined by the module type, and shall be defined in the system software through the application of a personality code. Simply changing the associated personality code may change module operation at any time. All addressing of the Addressable Modules shall be done electronically, and the electrical location of each module shall be automatically reported to the Fire Alarm Control Panel, where it may be downloaded into a PC, or printed out. The addressing of the modules will not be dependent on their electrical location on the circuit. All field wiring to the Addressable Modules shall be supervised for opens and ground faults and shall be location annunciated to the module of incidence. Diagnostic circuitry, and their associated indicators, with reviewable Trouble Codes, shall be integral to the Addressable Modules to assist in troubleshooting system faults.

Addressable Modules shall be used to provide supervised input circuits capable of latching operation for use with contact devices, non-damped water flow switches, non-latching supervisory sprinkler switches.

Addressable Control Relay Modules shall provide one form "C" dry relay contact rated at 2 amps @ 24 VDC or 0.5 amps at 120 VAC to, control external appliances or equipment processes. The control relay module shall be rated for pilot duty applications and releasing systems service. The position of the relay contact shall be confirmed by the system firmware.

ELECTRICAL GUIDELINES

The Addressable Fire Alarm Stations shall be a lexan double action fire alarm stations and fit in to a standard electrical box. Stations shall be key reset. Station shall be in red with white lettering. Where shown on drawings, provide tamper-resistant manual pull station cover. The cover shall be clear lexan, suitable for surface mount or semi-flush mount depending on the application. The cover shall have a local sounder option, which when operated, shall sound a local signal only.

All appliances which are supplied for the requirements of this specification shall be U.L. Listed for Fire Protective Service, and shall be capable of providing the “Equivalent Facilitation” which is allowed under the Americans with Disabilities Act Accessibilities Guidelines (ADA (AG)), and shall be UL 1971, and ULC S526 Listed. All appliances shall be of the same manufacturer as the Fire Alarm Control Panel specified to insure absolute compatibility between the appliances and the control panels, and to insure that the application of the appliances are done in accordance with the single manufacturers’ instructions. Audible devices shall be speaker type and visual devices shall be strobe type and shall be supplied by the same manufacturer as the Fire Alarm Control Equipment. The Strobes shall have a red or white plastic faceplate. They shall provide the proper candela output for the project per NFPA 72 spacing guidelines and synchronized flash outputs minimum requirements. The strobe shall have lens markings oriented for wall mounting.

Remote LCD annunciator shall have the full ability and duplicate in all fashion the main user interface located on the control panel. This includes the ability to control all system functions, tests, programming, and annunciations. Annunciator shall also include the ability to add programmable switches and or LED’s as required for special functions without the need to add additional wires or cabinets.

Provide supervised hard-wired Notification Appliance Circuits (NAC) for the control of 24VDC signaling appliances. Each NAC shall operate as a Class B (Style Y) circuit, and shall be capable of controlling up to 3.5 amps of signaling power.

Relays for remote control wiring, where the wiring is provided under another contract, shall have DPDT contacts rated 10 amperes at 115 VAC, minimum.

A digital communicator shall be provided. One eight circuit communicator shall be installed and connected to two separate telephone numbers in accordance with NFPA 72. All UL Standards and NFPA Standards for reliability shall be met. The Contractor shall verify all conditions relating to telephone numbers on both sending and receiving ends, being reliable according to NFPA Standards. All

ELECTRICAL GUIDELINES

equipment shall be UL listed and shall provide a detailed narrative description in the operation and maintenance manuals of the final installed conditions and arrangements, including telephone circuits used on-site and numbers call off-site. Once the new system is complete, tested, and accepted, it shall be placed in service and connected to the off-site, central station, fire alarm reporting service. The Contractor shall provide all necessary conductors, conduit and relays to terminate three signals (fire alarm, supervisory alarm, trouble) into a central station service interface and transmitter panel shall be in its own cabinet (not within the main panel) and shall be capable of being disconnected and removed without affecting the building system. The interconnection shall be supervised. Upon any fire alarm initiated by a water flow switch, manual station, thermal detector, or a verified smoke detector alarm, one general alarm signal shall be sent to the central station. Upon the activation of any supervisory switch in the building connected to circuits reporting to the CPU, one separate signal shall be forwarded off-site. Upon the activation of the main FACP trouble, one trouble signal shall be sent to the central station.

Provide contacts for each elevator in the elevator machine room that shall be activated whenever smoke or by-products of combustion are detected in any of the elevator lobbies served by the elevator, or in machine room, or in the hoist-way. Run No. 10 AWG conductors in raceway from each set of contacts to the applicable elevator controller. Terminate conductors with 12" taped slack in a junction box adjacent to elevator controller. Connect N.O. or N.C. as directed by Elevator Installer for return of elevator to main floor or designated alternate floor upon smoke detection by elevator lobby or machine room detectors. Detection of smoke in Main Floor Lobby shall signal elevator to go to alternate floor. Detection of smoke in lobby other than main floor lobby or in machine room shall signal elevator to go to main floor.

Furnish spare components to the Owner in the following quantities, but not less than one of each type of device used on the project: fuses – 2 of each type and size, manual stations – 2% of installed quantity, signal devices – 4% of installed quantity of each type and automatic detectors with bases – 6% of installed quantity of each type.

Wiring shall be in accordance with manufacturer's recommendations for proper system operation.

Signal line circuit cable for monitoring and control of addressable devices shall be not less than a #18 AWG twisted shielded pair type FPL/FPLR/FPLP fire alarm cable. Unless specifically noted or approved otherwise, other conductors shall be of stranded copper not smaller than #14 AWG, with THWN/

ELECTRICAL GUIDELINES

THHN insulation.

All wiring shall be in metal raceway, unless specifically shown otherwise. Raceways shall be sized for the wiring requirements of the system proposed, with maximum conduit fill of 40%.

In multistory buildings, all wiring leaving the riser on each floor shall run through a labeled terminal block located in a hinged cabinet accessible from the floor. Terminations shall have pressure wire connectors of the self-lifting or box lug type.

Automatic detectors shall be located at least three feet from any HVAC diffuser.

All addressable loop controller (signaling line) circuits shall be Class A with no T-taps made. Each circuit shall have minimum 20% spare addresses for future use.

All junction and connection boxes shall be painted red for easy identification.

Field Connected Devices must be installed and wired by a Factory Trained and Authorized Fire Alarm System Sub-Contractor or a licensed electrical contractor under direct supervision of a Factory Trained and Authorized Fire Alarm System Sub-Contractor.

All auxiliary Power Supplies or other Fire Panels shall be located in electrical or mechanical rooms. They shall be mounted at a height between 48 to 60 inches from floor level. All such panels shall be “supervised” by the main Fire Alarm Panel. A smoke detector shall be located on the ceiling within five feet of all auxiliary power supplies.

Isolation modules shall be provided as follows: After each 20 devices and control points on any addressable loop, for each addressable circuit that extends outside the building walls. On each end of each addressable loop at the fire alarm control panel and within 15 feet and in the same room as the FACP, for addressable loops extending beyond one floor, install isolator module at terminal cabinet on each floor. Each isolation module shall be clearly labeled and readily accessible.

No wiring associated with the fire alarm system shall be spliced other than at device or cabinet terminal blocks. Permanent wire markers shall be used to identify all connections at the fire alarm control panel, power supplies and terminal cabinets.

Provide all necessary power and control wiring for smoke dampers furnished and installed by Mechanical Contractor. Coordinate voltage requirements for smoke damper actuators with Mechanical Contractor.

Duct smoke detectors shall be furnished and wired by Electrical Contractor and installed by Mechanical Contractor. Coordinate installation, including sam-

pling tube, with Mechanical Contractor.

Provide all necessary power and control wiring for magnetic door holder devices. Coordinate installation with Door Hardware Installer.

Final system connections shall be made by or under the direct supervision of an authorized representative of the manufacturer, who shall verify to the Architect/Engineer that the system has been left in full and proper operating condition.

Manufacturer's representative and a Record of Completion presented upon completion shall verify system installation and operations. The manufacturer's representative shall be responsible for an on-site demonstration of the operation of the system and initial staff training.

Manufacturer shall supply a 2 year warranty from date of manufactured Control System and Field Devices and appliances. System shall be maintained in perfect operating condition for a period of two years following completion of the project, at no additional cost to the Owner.

Manufacturer shall maintain a service organization with adequate spare parts stock within 50 miles of the installation. Any defects that render the system inoperative shall be repaired within 24 hours of the owner notifying the contractor. Other defects shall be repaired within 48 hours of the owner notifying the contractor.

All equipment shall be properly grounded. Main panel shall be grounded directly to 'earth ground'. Surge protection and lightning arrestors shall be installed on the AC supply and all initiating, notification and monitoring circuits. All surge protection shall be Ditek or equivalent. Ditek DTK-LVLP Series for low voltage data and signal line protection. Ditek DTK-HW Series for hard wire AC protection for 120 VAC. Install the suppressor in a listed enclosure near the electrical panelboard and trim excess lead lengths.

The Fire Alarm System Installer shall schedule and execute an instruction class for the Building owner, which details the proper operation of the installed fire alarm system. The instruction shall also cover the schedule of maintenance required by NFPA 72 and any additional maintenance recommended by the system manufacturer. The training shall include how to access the multiple access levels to make changes to the system's alarm inputs and outputs.

The instruction shall be a minimum of 8 hours in duration and presented in an organized and professional manner by a person factory trained in the operation and maintenance of the equipment and who is also thoroughly familiar with the installation.

Communications

DIVISION 27

Contents

- 27-02 General
- 27-02 Cabling
- 27-02 Lighting Coordination with A/V
- 27-03 Classroom and Conference Room A/V Standards
- 27-04 Closets
- 27-04 Digital Signage

COMMUNICATIONS

As a subset of the Information Systems Department, the Media Solutions group handles the audio visual (A/V) standards, resources and training for the University. This section will cover A/V requirements and reference directly related and/ or coordinated systems.

General

These design guidelines will be utilized on each University project. Variances from these guidelines shall be submitted to Facilities and Campus Services and, if approved in writing, may be incorporated into the program for a specific project. Technology for multimedia solutions is constantly evolving, therefore standards are updated frequently. ICIA (InfoComm International Association) and ANSI set industry accepted performance standards and rules of thumb for the information communications industry. The Media Solutions group employs these standards as a starting point and goes further to customize requirements and methods specific to WFU. The Media Solutions group shall be consulted early in the design process, preferably during programming and schematic design, to ensure that the most current technology and thinking, specific to Wake Forest University, is taken into account. User education on the complexity, use and cost of these systems begins at this point as well. Accurately accounting for A/V cost in the total project budget is key early on and designers will be expected to facilitate this process.

Cabling

As of the composition of this document Category 5 cabling is the minimum standard for all applications on campus. The Media Solutions group shall be consulted on every project to ensure that requirements are up to date with current University standards.

Lighting Coordination with A/V

The University prefers Lutron technology for controlled lighting systems. The lighting design and lighting control shall not be considered independent of the design for audio visual technology in any spaces on campus. The design team shall coordinate the two disciplines even though one is specified by the project engineer and the other by the University.

COMMUNICATIONS

Classroom and Conference Room A/V Standards

The Media Solutions group maintains a standard for all classroom fit out and upgrades. With regard to building systems integration and support the following are the minimum standards:

- ◆ *Two (2) Data and One (1) CATV are required at the equipment rack location.*
- ◆ *Power is required at the ceiling mounted projector as well as the equipment rack location.*
- ◆ *Power must be on clean 20A circuits. The projector equipment rack must be on the same electrical phase.*
- ◆ *If “NEW” construction – minimum of One (1) 1 inch conduit is required above accessible ceilings to the equipment rack location. Two (2) ¾ inch conduits are preferred.*
- ◆ *All Category 5e/6 AV cabling must be plenum rated STP in “Blue”.*
- ◆ *Screen size, and therefore space design, should be determined by screen H (1/6) the max view distance and the bottom of the screen should be at least 36 inches off the floor.*
- ◆ *When recording lectures or discussions is considered for a space a minimum of 2 but usually 3 video/ audio cameras are included in the design.*
- ◆ *The design team must carefully coordinate location of HVAC registers, diffusers and equipment in order to prevent A/V contamination with vibrations, white noise and space conflicts.*
- ◆ *As a general rule of thumb, rooms that require the use of speakers are well-served with finishes that are sound absorbing. This reduces reflections and reverberations and usually reduces the audio equipment needs.*
- ◆ *In addition to the building requirements, the Media Solutions group maintains an equipment list that may be provided to the design team for consideration in coordinating systems and design parameters. That document changes very frequently as equipment changes and it is therefore not included in this guideline. Please consult with the Media Solutions group.*

Closets

CATV will be in tele/data closets and must be coordinated with the Information Systems Department. Audio visual equipment will either be housed in its own closet or in multi-bay credenzas in the rooms they serve. If equipment is to be housed in a built-in closet, cooling with the HVAC system must be provided.

Digital Signage

As communication is continually evolving to include mixed media, the request for digital signage is increasing. WFU is incorporating digital signage in some applications. At present the University plans to provide information only digital signage across the University cable system. Interactive signage will either be point of use or managed across the University data network.

Electronic Safety & Security

DIVISION 28

Contents

- 28-02 Electronic Safety and Security
- 28-02 Card Access
- 28-02 Surveillance Cameras
- 28-03 Emergency Blue Light Phone Stations
- 28-03 Campus Address Systems
- 28-03 Electronic Security for Residence Halls
- 28-04 Electronic Security for Academic Buildings
- 28-04 Electronic Security for Library Facilities

Electronic Safety and Security

Physical and Electronic Security are ever intertwined and are becoming less and less mutually independent. This section will cover card access, surveillance cameras, emergency telephone, campus perimeter security; will reference lighting as it relates to security and public address systems.

Card Access

Card Access is managed by the Deacon OneCard office, which is a subset of Residence Life and Housing. This office is responsible for all the facilities on the Reynolda Campus and the satellite campus in Charlotte. Different facilities required different types of security and access. Each project, new construction or renovation shall consider the security needs and requirements early on in the programming and schematic design phases. All access control including video surveillance, card access control and alarm notifications are managed through the Deacon OneCard office. The Deacon OneCard office will provide guidelines for construction upon request that specifies minimum requirements for card access and camera systems installation. The following shall be considered in building design:

- ◆ *All card readers shall fail secure, which means a card reader can never prevent one from exiting via a required means of egress.*
- ◆ *The University prefers to have card access controls systems backed up by building emergency generator back up or battery back-up.*
- ◆ *All card readers shall be key override.*

The University will own and manage these systems post construction. The ability of the University to monitor and service these systems after construction is directly proportional to the design team's coordination and inclusion with them during the design and construction process. This is one of the biggest hurdles the Deacon OneCard office faces in managing electronic security across campus. Therefore, the design team shall include the Deacon OneCard office in all phases of a project's development and documentation.

Surveillance Cameras

Cameras are primarily used for recording pedestrian and vehicular traffic and access and for asset protection, i.e. a deterrent. In general, cameras shall be planned for and provided wherever there are assets to protect, i.e. computers, data centers, memorabilia, art and records, at all loading docks and at all building entries. Every vehicular and pedestrian campus access points shall have cameras

ELECTRONIC SAFETY & SECURITY

recording entry and exit from campus. Pedestrian access point shall have card access controlled gates with blue light emergency phones. All parking lots are to be equipped with card access controlled gate arms and surveillance cameras on light poles. All blue light emergency phones are to also be equipped with cameras. Infrared cameras should be considered for dark areas where surveillance is required. Projects should plan for pan-tilt-zoom cameras at all light pole stations and fixed cameras and entry/exit points.

Emergency Blue Light Phone Stations

When site planning, emergency blue light phones shall be considered on all projects which disturb the ground plane, affect campus circulation and affect visibility around buildings and views through campus. Blue light phones are to be visible from all points on campus and there should be a clear line of site between stations. The University would prefer that blue light phones enable broadcast messages and communications. While blue light phones are typically limited to exterior use, design teams should consider locating emergency call boxes on each building's floor especially residence halls.

Campus Address Systems

Wake Forest University currently employs a Federal Big Voice system for outdoor alerts. Interior building address systems should be considered for each new building project or major renovation. Currently, the service provider for IP Emergency Phones and the public address system is Valcom, www.valcom.com. The long term desire of the University is to be able to provide public address, for exterior and interior spaces via an addressable fire alarm system activated from one central location.

Electronic Security for Residence Halls

The following guidelines apply to all on-campus housing facilities. Off-campus housing facilities will be considered on a case-by-case basis.

- ◆ *All doors that make sense as entry doors shall be equipped or at least prepped for easy installation of a card access system.*
- ◆ *All residence halls to have an ADA/ANSI accessible door opener.*
- ◆ *Card Access is not to be located in elevators.*
- ◆ *Card Access is to be provided on kitchens, study rooms, trash rooms, recreation/ media rooms, classrooms, custodial offices and resident suite doors.*
- ◆ *Card readers or prep for card readers should be considered for*

Handicap Accessible rooms in the case the push button access may be required in the future.

- ◆ *Exterior stair doors are to have monitored alarms which will indicate when a door is opened and closed and which will sound locally and notify campus police.*
- ◆ *Media rooms shall have door prop alarms.*
- ◆ *Exterior security cameras (type will vary by application) shall cover courtyards, building access points and parking areas.*
- ◆ *Interior security cameras may only view common areas, entry ways, lounges, corridors, stairwells, and study spaces.*
- ◆ *Video storage must be included with camera installation. University Video Surveillance Policy requires 90 days storage per camera.*

Electronic Security for Academic Buildings

Academic buildings which generally consist of administration and classroom facilities must have the ability to lock every exterior door on command. This means that all exterior doors are always locked or if open must have card access for on command electronic control. Regardless of location, all exterior doors shall be prepped for easy addition of future card access.

- ◆ *Card access must be provided on at least two exterior doors.*
- ◆ *Card access is preferred on every classroom door, and at the least the frame and door should be prepped for easy addition of future card access.*
- ◆ *Card access should be provided to the main suite door of office suites.*
- ◆ *All meeting, seminar and conference rooms are to prepped for card access.*

Electronic Security for Library Facilities

The following guidelines apply to the main campus library and all secondary library facilities:

- ◆ *All building entrances shall be equipped with card access and a camera.*
- ◆ *Rare books and special collections should be equipped with card access and cameras.*
- ◆ *Exit only doors shall be equipped with door prop/ open alarms.*
- ◆ *Exterior study spaces which may include balconies and courtyards, loading dock, circulation desk, auditoria, meeting rooms and seminar rooms shall all be equipped with cameras.*